

AGENDA  
 IRVINE RANCH WATER DISTRICT  
 ENGINEERING AND OPERATIONS COMMITTEE MEETING  
 TUESDAY, MAY 19, 2026

This meeting will be held in-person at the Michelson Water Recycling Plant located at 3512 Michelson Drive, Irvine, California. The meeting will also be broadcasted via Webex for those wanting to observe the meeting virtually.

To observe this meeting virtually, please join online using the link and information below:

Via Web: <https://irwd.webex.com/irwd/j.php?MTID=m67f401f70fd8332a7ee6b183fe231488>  
 Meeting Number (Access Code): 2492 213 2953  
 Meeting password: h5eSQz25Cew

PLEASE NOTE: Webex observers of the meeting will be placed into the Webex lobby when the Board enters closed session. Participants who remain in the “lobby” will automatically be returned to the open session of the Board once the closed session has concluded. Observers joining the meeting while the Board is in closed session will receive a notice that the meeting has been locked. They will be able to observe the meeting once the closed session has concluded.

CALL TO ORDER 1:30 p.m.

ATTENDANCE Committee Chair: Doug Reinhart \_\_\_\_\_  
 Committee Member: John Withers \_\_\_\_\_

ALSO PRESENT

Paul Cook	_____	Kevin Burton	_____	Wendy Chambers	_____
Neveen Adly	_____	Paul Weghorst	_____	Steve Choi	_____
Jim Colston	_____	Jason Manning	_____	Jose Zepeda	_____
Eric Akiyoshi	_____	Belisario Rios	_____	Jacob Moeder	_____
Brian Waite	_____	Lori Rigby	_____	Scott Giatpaiboon	_____
_____	_____	_____	_____	_____	_____
_____	_____	_____	_____	_____	_____
_____	_____	_____	_____	_____	_____
_____	_____	_____	_____	_____	_____
_____	_____	_____	_____	_____	_____

PUBLIC COMMENT NOTICE

If you wish to address the Committee orally on any item, you may attend the meeting in person and submit a “speaker slip” to the Committee Chair. Forms are provided at the front of the Committee Room. Public comments are limited to three minutes per speaker on each subject. If you wish to submit written comments to the Committee, please submit your public comment in advance of the meeting by emailing [comments@irwd.com](mailto:comments@irwd.com) before 5:00 p.m. on Monday, May 18, 2026, and your remarks will be added to the record at the meeting.

---

**COMMUNICATIONS**

---

1. Notes: Burton
2. Public Comments
3. Determine the need to discuss and/or take action on item(s) introduced that came to the attention of the District subsequent to the agenda being posted and determine which items may be approved without discussion.

---

**PRESENTATION**

---

4. TOUR OF SELECT IRWD OPERATIONS CENTER FACILITIES

---

**INFORMATION**

---

5. PROJECT STATUS REPORT – BURTON  
Recommendation: Receive and file.
6. IRWD RESEARCH BUSINESS PLAN UPDATE – COLSTON / BURTON  
Recommendation: Receive and file.

---

**ACTION**

---

7. FY 2026-27 PIPELINE REPLACEMENT PROJECT ADDITIONS – EDWARDS / AKIYOSHI / BURTON  
  
Recommendation: That the Board authorize the addition of the Warner Avenue Recycled Water Pipeline Replacement, Project 13560 in the amount of \$2,310,000 to the FY 2026-27 Capital Budget; authorize the addition of the Portola Springs Domestic Water Pipeline Rehabilitation, Project 13651 in the amount of \$3,778,000 to the FY 2026-27 Capital Budget; authorize the addition of the Portola Springs Recycled Water Pipeline Rehabilitation, Project 13562 in the amount of \$3,512,000 to the FY 2026-27 Capital Budget; and authorize the addition of the University Park Domestic Water Pipeline Replacement, Project 13563 in the amount of \$4,480,000 to the FY 2026-27 Capital Budget.

---

**ACTION (continued)**

---

8. FISCAL YEARS 2025-26 GENERAL REPLACEMENTS AND MODIFICATIONS PROJECTS BUDGET INCREASES – ROBINSON / AKIYOSHI / BURTON

Recommendation: That the Board authorize a budget increase for Project 12521 in the amount of \$1,417,000, from \$6,283,000 to \$7,700,000; authorize a budget increase for Project 12523 in the amount of \$497,000, from \$2,103,000 to \$2,600,000; and authorize a budget increase for Project 12525 in the amount of \$1,315,000, from \$1,785,000 to \$3,100,000, for the Fiscal Year 2025-26 General System Replacements and Modifications projects.

9. MICHELSON WATER RECYCLING PLANT SOLIDS HANDLING IMPROVEMENTS VARIANCE AND BUDGET INCREASE – MURPHY / WAITE / BURTON

Recommendation: That the Board authorize a budget increase in the amount of \$10,670,000, from \$1,065,000 to \$11,735,000, and authorize the General Manager to approve Variance No. 1 with Carollo Engineers, Inc. in the amount of \$394,974 for additional engineering design services for the Michelson Water Recycling Plant Solids Handling Improvements, Project 12555.

10. EAST IRVINE ZONE 3-4 PUMP STATION REHABILITATION CONSULTANT SELECTION AND BUDGET ADJUSTMENT – ALVAREZ / WAITE / BURTON

Recommendation: That the Board authorize a budget increase in the amount of \$3,780,000, from \$2,500,000 to \$6,280,000, and authorize the General Manager to execute a Professional Services Agreement with Jacobs in the amount of \$938,942 for engineering design services for the East Irvine Zone 3-4 Pump Station Rehabilitation, Project 12565.

---

**OTHER BUSINESS**

---

11. Directors' Comments

12. Adjournment

\*\*\*\*\*  
Availability of agenda materials: Agenda exhibits and other writings that are disclosable public records distributed to all or a majority of the members of the above-named Committee in connection with a matter subject to discussion or consideration at an open meeting of the Committee are available for public inspection in the District's office, 15600 Sand Canyon Avenue, Irvine, California ("District Office"). If such writings are distributed to members of the Committee less than 72 hours prior to the meeting, they will be available from the District Secretary of the District Office at the same time as they are distributed to Committee Members, except that if such writings are distributed one hour prior to, or during, the meeting, they will be available electronically via the Webex meeting noted. Upon request, the District will provide for written agenda materials in appropriate alternative formats, and reasonable disability-related modification or accommodation to enable individuals with disabilities to participate in and provide comments at public meetings. Please submit a request, including your name, phone number and/or email address, and a description of the modification, accommodation, or alternative format requested at least two days before the meeting. Requests should be emailed to [comments@irwd.com](mailto:comments@irwd.com). Requests made by mail must be received at least two days before the meeting. Requests will be granted whenever possible and resolved in favor of accessibility.

Note: This page is intentionally left blank.

May 19, 2026

Prepared by: E. Akiyoshi / J. Moeder /  
B. Rios / B. Waite

Submitted by: K. Burton

Approved by: Paul A. Cook 

ENGINEERING AND OPERATIONS COMMITTEE

PROJECT STATUS REPORT

SUMMARY:

A status report of Irvine Ranch Water District's Projects is presented to the Committee for information.

BACKGROUND:

The information, which is provided as Exhibit "A", is a status report submitted quarterly to the Committee for review.

FISCAL IMPACTS:

Not applicable.

ENVIRONMENTAL COMPLIANCE:

Not applicable.

RECOMMENDATION:

Receive and file.

LIST OF EXHIBITS:

Exhibit "A" – Project Status Report

Note: This page is intentionally left blank.

ENGINEERING PROJECT STATUS REPORT

	Project Name	Project No.	Code	Engineering Team			Planning/Study Phase		Design Phase						Construction Phase			
				Group	Program Manager	Project Manager	Status	Completion	Status	Consultant	PDR / 30%	60%	90%	100%	Status	Contractor	In Service	Final Acceptance
1	MWRP Tertiary Filter Rehabilitation	07892	7764	Treatment & Conveyance	Waite	Alvarez	Completed	-	Completed	HDR	Completed	Completed	Completed	Completed	In-Process	ICS	Dec-26	Feb-27
2	MWRP Fueling Facilities	07881/07882	7706	Treatment & Conveyance	Waite	Alvarez	Completed	-	Completed	AECOM	Completed	Completed	Completed	Completed	In-Process	ICS	Jun-26	Aug-26
3	Coastal Zones B&D and Coastal Zone OC-63 to Zone 4 Pump Stations Rehabilitation	11568/13506	8426/8427	Treatment & Conveyance	Waite	Alvarez	Completed	-	In-Process	Carollo	Jul-26	Sep-26	Dec-26	Mar-27	Apr-27	-	-	Aug-28
4	MWRP 2025 Flows and Loads Update (Phase III Expansion)	01659/01797	N/A	Treatment & Conveyance	Waite	Alvarez	In-Process	Aug-26	N/A	HDR	-	-	-	-	N/A	-	-	N/A
5	BWTP Access Road Drainage Improvements	12521		Treatment & Conveyance	Waite	Alvarez	Completed	-	In-Process	In-House	Completed	Completed	Completed	Jun-26	Jul-26	-	-	Sep-26
6	MWRP Handrail Safety Improvements	12525	8472	Treatment & Conveyance	Waite	Alvarez	Completed	-	In-Process	CDA	-	Jun-26	Jul-26	Aug-26	Oct-26	-	-	Aug-27
7	East Irvine Zone 3-4 Pump Station Rehabilitation	12565	8428	Treatment & Conveyance	Waite	Alvarez	Completed	-	May-26	Jacobs	Sep-26	Nov-26	Jan-27	May-27	Aug-27	-	-	Dec-28
8	Fleming Tank and Pump Station Improvements	10101	7614	Treatment & Conveyance	Waite	Burk	Completed	-	Completed	Tetra Tech	Completed	Completed	Completed	Completed	In-Process	Pacific Hydrotech	May-26	Aug-26
9	HWTP Interconnection Pipeline	13149	8327	Treatment & Conveyance	Waite	Burk	Completed	-	In-Process	West Yost	Completed	Completed	Jul-26	Sep-26	Oct-26	-	-	Jul-27
10	HWTP Pump Station Improvements	13174	8328	Treatment & Conveyance	Waite	Burk	Completed	-	In-Process	MKN	Jul-26	Oct-26	Dec-26	Mar-27	May-27	-	-	May-28
11	Wells 6, 12, 14, and 15 Site Improvements	11570	8312	Treatment & Conveyance	Waite	Foo	Completed	-	In-Process	Tetra Tech	Completed	Completed	Completed	Jul-26	Oct-26	-	-	May-29
12	Sand Canyon Headquarters and Operations Center HVAC Upgrades	12550/12551	8262	Treatment & Conveyance	Waite	Foo	Completed	-	In-Process	Eng Resource Mech	Completed	Completed	Completed	Apr-26	Jul-26	-	-	Jan-28
13	Silverado Canyon Bridge 174 Domestic Water Pipeline Improvements	11588	7836	Treatment & Conveyance	Waite	Foo	Completed	-	Completed	Mark Thomas	Completed	Completed	Completed	Completed	In-Process	Ferreira	Jan-28	Feb-28
14	Silverado Canyon Bridge 175 Domestic Water Pipeline Improvements	11587	7618	Treatment & Conveyance	Waite	Foo	Completed	-	In-Process	Mark Thomas	Completed	Completed	Completed	Jul-26	Feb-27	-	-	May-27
15	Silverado Canyon Bridge 177 Domestic Water Pipeline Improvements	11589	8147	Treatment & Conveyance	Waite	Foo	Completed	-	Completed	MBF Consulting	Completed	Completed	Completed	Completed	In-Process	Ferreira	Aug-27	Sep-27
16	Operations Center Warehouse and Water Quality Storage Building	11854/11855	7796	Treatment & Conveyance	Waite	Foo	Completed	-	Completed	Stantec	Completed	Completed	Completed	Completed	In-Process	KPRS	Nov-26	Dec-26
17	Rehabilitation of Dyer Road Wellfield Well No. 7	13252	8320	Treatment & Conveyance	Waite	Foo	Completed	-	Completed	Richard Slade	Completed	Completed	Completed	Completed	In-Process	Best Drilling	Jun-26	Jul-26
18	Manning Pump Station Replacement	13191	8322	Treatment & Conveyance	Waite	Murphy	Completed	-	In-Process	Lee & Ro	Completed	Completed	Completed	Completed	Jul-26	-	-	Jul-27
19	MWRP Biosolids Lift Station and Sewer Pipeline	12541	8098	Treatment & Conveyance	Waite	Murphy	Completed	-	Completed	Tetra Tech	Completed	Completed	Completed	Completed	In-Process	Paulus Engineering	Feb-27	Apr-27
20	Radio Tower Improvements	11154/11156/11157	8099	Treatment & Conveyance	Waite	Murphy	Completed	-	Completed	Civiltec	Completed	Completed	Completed	Completed	In-Process	Southern Contrating Co.	May-26	Jun-26
21	MWRP Biosolids Handling Improvements	12555	8412	Treatment & Conveyance	Waite	Murphy	Completed	-	In-Process	Carollo	Completed	May-26	Aug-26	Nov-26	Jan-27	-	-	Jan-29
22	Lake Forest Woods Sewer Improvements	11123	7936	Treatment & Conveyance	Waite	Murphy	Completed	-	Completed	Woodard & Curran	Completed	Completed	Completed	Completed	In-Process	GCI	Sep-26	Nov-26
23	Coastal Zone 1 to 2 and Zone 2 to 4 Pump Stations Rehabilitations	11912	7925	Treatment & Conveyance	Waite	Murphy	Completed	-	Completed	GHD	Completed	Completed	Completed	Completed	In-Process	SS Mechanical	Dec-26	Jan-27
24	SOCWA Pump Station Tank Wall Repair	12527		Treatment & Conveyance	Waite	Ovcharenko	On Hold	-	On Hold	-	-	-	-	-	On Hold	-	-	On Hold
25	LAWRP Ponds Biosolids Removal and Land Application	13424	8388	Treatment & Conveyance	Waite	Spangenberg	Completed	-	Completed	In-House	Completed	Completed	Completed	Completed	In-Process	Synagro	Feb-27	Feb-27
26	Santiago Creek Dam Improvements	01813	7975	Dams & Storage	Moeder	Moeder	Completed	-	In-Process	AECOM/GEI	Completed	Completed	May-26	Aug-26	Nov-26	-	-	Dec-31
27	Rattlesnake Dam Risk Reduction Investigation	12101	N/A	Dams & Storage	Moeder	Moeder	In-Process	Jun-26	N/A	HDR	-	-	-	-	N/A	-	-	N/A
28	Orange Heights Zone 6 Reservoir	07138	6892	Dams & Storage	Moeder	Moeder	Completed	-	On Hold	Tetra Tech	Completed	Completed	Completed	-	-	-	-	-
29	Sand Canyon Dam Seepage and Instrumentation Upgrades	13232/12506	8101	Dams & Storage	Moeder	Bernal	Completed	-	In-Process	GEI	Completed	Completed	Jun-26	Sep-26	Nov-26	-	-	May-27
30	BWTP Chemical Line Repair	13200	8436	Dams & Storage	Moeder	Bernal	Completed	-	In-Process	Carollo	Completed	Completed	Completed	Jun-26	Jul-26	-	-	Mar-27
31	San Joaquin Reservoir Outlet Valve Replacement	13111	8223	Dams & Storage	Moeder	Bernal	Completed	-	Completed	In-House	Completed	Completed	Completed	Completed	Jun-26	-	-	Dec-26
32	Sewer Siphon Improvements Phase II	11841	7916	Dams & Storage	Moeder	Lu	Completed	-	Completed	Woodard & Curran	Completed	Completed	Completed	Completed	In-Process	Mike Pritch & Sons	Jun-26	Jul-26
33	San Joaquin Reservoir Filtration	10379	7622	Dams & Storage	Moeder	Lu	Completed	-	Completed	Carollo	Completed	Completed	Completed	Completed	In-Process	RC Foster	Apr-26	Jun-26
34	Rattlesnake Dam Outlet Pipeline Rehabilitation	12101	8422	Dams & Storage	Moeder	Lu	Completed	-	In-Process	MKN	Completed	Completed	May-26	Jun-26	Jul-26	-	-	Jul-27
35	HWTP Supply Pipeline Vault Rehabilitations	13190	8437	Dams & Storage	Moeder	Lu	Completed	-	In-Process	WSC	Jun-26	Sep-26	Nov-26	Mar-27	May-27	-	-	Jun-28
36	Orange Heights Zn 5 to 6 and C+ to E Pump Stations	07136/07139	8286	Dams & Storage	Moeder	Lu	Completed	-	On Hold	Lee & Ro	-	-	-	-	On Hold	-	-	On Hold
37	District-Wide Generator Fuel Storage Upgrades	11536/11537	7955	Dams & Storage	Moeder	Mwe	Completed	-	Completed	Psomas	Completed	Completed	Completed	Completed	In-Process	SS Mechanical	Jul-26	Jul-26
38	San Joaquin Dam Drainage Improvements	13166	8269	Dams & Storage	Moeder	Mwe	Completed	-	Completed	JIG	Completed	Completed	Completed	Completed	In-Process	-	Nov-26	Nov-26
39	Lake Forest Zone 4 Tanks Rehabilitation	12568	8104	Dams & Storage	Moeder	Mwe	Completed	-	Completed	Cannon	Completed	Completed	Completed	Completed	In-Process	Orion Construction	Jun-27	Jun-27
40	Shaw Tank Replacement	12569	8331	Dams & Storage	Moeder	Mwe	Completed	-	In-Process	Tetra Tech	May-26	Jul-26	Oct-26	Dec-26	Feb-27	-	-	Aug-28
41	MWRP Acid Phase Digester Rehabilitation	12552	8435	Dams & Storage	Moeder	Mwe	Completed	-	In-Process	V&A	N/A	Jun-26	Jul-26	Aug-26	Sep-26	-	-	Aug-27
42	Sand Canyon Dam Liner Repair	12524	8465	Dams & Storage	Moeder	Mwe	Completed	-	Completed	In-House	Completed	Completed	Completed	May-26	Oct-26	-	-	Nov-26
43	Syphon Reservoir Improvements	03808	7847	Dams & Storage	Moeder	Radvar	Completed	-	Completed	AECOM	Completed	Completed	Completed	Completed	In-Process	Sukut	May-31	May-31
44	Eastwood Zn A-Syphon Pump Station Equipping	11831	8461	Dams & Storage	Moeder	Radvar	Completed	-	In-Process	AECOM	-	-	-	-	-	-	-	-
45	MWRP Influent Meters (North and South)			Dams & Storage	Moeder	Radvar	In-Process	Feb-27	-	-	-	-	-	-	-	-	-	-
46	Santiago Creek Dam Improvements - Site Prep	01813	8411	Dams & Storage	Moeder	Sanchez	Completed	-	Completed	AECOM/GEI	Completed	Completed	Completed	Completed	In-Process	James W. Fowler Co.	Jan-27	Jan-27
47	Syphon Reservoir Improvements - Zone C to Syphon Intertie at Eastwood PS	03808	8444	Dams & Storage	Moeder	Sanchez	Completed	-	Completed	AECOM	Completed	Completed	Completed	Completed	In-Process	SS Mechanical	Jun-26	Jun-26
48	Harding Canyon Dam Rehabilitation/Removal Study	12513	N/A	Dams & Storage	Moeder	Sanchez	In-Process	Apr-27	N/A	Geosyntec	-	-	-	-	N/A	-	-	N/A
49	I-5 Widening Sand Canyon 12 inch DW Relocation Seg 1	13205	8336	Development & Pipelines	Rios	Botello	Completed	-	Completed	JIG	Completed	Completed	Completed	Completed	In-Process	T.E. Roberts	Aug-26	Aug-26
50	I-5 Widening Sand Culver 36 inch RW Relocation Seg 2	13204	8337	Development & Pipelines	Rios	Botello	Completed	-	Completed	JIG	Completed	Completed	Completed	Completed	In-Process	L&S	Sep-26	Sep-26

**ENGINEERING PROJECT STATUS REPORT**

	Project Name	Project No.	Code	Engineering Team			Planning/Study Phase		Design Phase						Construction Phase			
				Group	Program Manager	Project Manager	Status	Completion	Status	Consultant	PDR / 30%	60%	90%	100%	Status	Contractor	In Service	Final Acceptance
51	Modjeska Grade Road DW Pipeline Relocation	13238	8285	Development & Pipelines	Rios	Botello	Completed	-	In-Process	JIG	Completed	Completed	Completed	Jun-26	Jul-26	-	-	Jan-27
52	Orange Heights SAC/Baker Pipeline Relocation	02766	6691	Development & Pipelines	Rios	Botello	Completed	-	Completed	MBI	Completed	Completed	Completed	Completed	On Hold	-	-	On Hold
53	Effluent Transmission Main Reach A Rehabilitation	11842	8438	Development & Pipelines	Rios	Botello	In-Process	May-26	Jun-26	-	-	-	-	-	Apr-27	-	-	Dec-28
54	Effluent Transmission Main Reach B Replacement	11906	N/A	Development & Pipelines	Rios	Botello	Completed	-	In-Process	BKF	-	-	-	-	Mar-27	-	-	Oct-28
55	San Joaquin Hills Road RW Pipeline Replacement	13113	8440	Development & Pipelines	Rios	Botello	Completed	-	In-Process	MKN	May-26	Jun-26	N/A	Jul-26	Nov-26	-	-	May-27
56	Silkwood/Willowleaf RW Pipeline Replacement	10580	8441	Development & Pipelines	Rios	Botello	Completed	-	In-Process	Ardurra	Completed	May-26	N/A	Jun-26	Nov-26	-	-	May-27
57	Recycled Water PRVs Decommissioning	13160	8305	Development & Pipelines	Rios	Ige	Completed	-	Completed	WSC	Completed	Completed	Completed	Completed	In-Process	Ferreira	May-26	Jun-26
58	Turtle Rock/Concordia RW Pipeline Replacement	13162	8321	Development & Pipelines	Rios	Ige	Completed	-	Completed	West Yost	Completed	Completed	Completed	Completed	In-Process	Ferreira	Jun-26	Jun-26
59	Irvine Business Complex Appurtenance Relocations Phase 3	12827	8096	Development & Pipelines	Rios	Ige	Completed	-	Completed	MBF Consulting	Completed	Completed	Completed	Completed	May-26	-	-	Dec-26
60	Modjeska Harding DW Pipeline Replacement	13525	8445	Development & Pipelines	Rios	Ige	In-Process	May-26	-	-	-	-	-	-	-	-	-	-
61	EV Charging Facilities - Sand Canyon	12971	8382	Development & Pipelines	Rios	Ige	Completed	-	Completed	SCE/NV5	Completed	Completed	Completed	Completed	Aug-26	-	-	Nov-26
62	EV Charging Facilities - Operations Center	12971	8382	Development & Pipelines	Rios	Ige	Completed	-	In-Process	SCE/BCF	Completed	Completed	Completed	May-26	Aug-26	-	-	Nov-26
63	PA 51 Marine Way Stage 4 from Lynx to OCTA Rail (RA with Heritage Fields)	13099/13100/13101	8180	Development & Pipelines	Rios	Kuan	Completed	-	Completed	Proactive	N/A	N/A	N/A	N/A	Nov-26	-	-	Jun-26
64	PA 51 Framework DW, SS, RW	13463/13464/13465	8301	Development & Pipelines	Rios	Kuan	Completed	-	In-Process	Huitt Zollars	N/A	N/A	N/A	N/A	May-26	-	-	Jan-27
65	PA 2, Gateway Village In Tract Backbone DW, RW (RA with City)	13466/13467	8379	Development & Pipelines	Rios	Kuan	Completed	-	In-Process	Fuscoe	N/A	N/A	N/A	N/A	Jun-26	-	-	Jan-27
66	PA 2, Gateway Village Offsite DW (RA with City)	13482	8396	Development & Pipelines	Rios	Kuan	Completed	-	In-Process	Fuscoe	N/A	N/A	N/A	N/A	Jun-26	-	-	Jan-27
67	PA 2, Gateway Village Offsite SS (RA with City)	13483	8397	Development & Pipelines	Rios	Kuan	Completed	-	In-Process	Fuscoe	N/A	N/A	N/A	N/A	Jun-26	-	-	Jan-27
68	East Orange, Orange Heights Tract 16199 SS, RW (RA with TIC)	07484/07486	6762	Development & Pipelines	Rios	Kuan	Completed	-	In-Process	Wilson Mikami	N/A	N/A	N/A	N/A	Sep-27	-	-	Dec-28
69	East Orange, Orange Heights Tract 17995 DW, RW (RA with TIC)	07376/07377	7986	Development & Pipelines	Rios	Kuan	Completed	-	In-Process	Proactive	N/A	N/A	N/A	N/A	Sep-27	-	-	Dec-28
70	East Orange, Orange Heights Jamboree and Chapman DW SS, RW (RA with TIC)	07451/07452/07453	6815	Development & Pipelines	Rios	Kuan	Completed	-	In-Process	MBI	N/A	N/A	N/A	N/A	Sep-27	-	-	Dec-28
71	East Orange, Orange Heights Neighborhood J2/J3 DW, (RA with TIC)	13324	8324	Development & Pipelines	Rios	Kuan	Completed	-	In-Process	Wilson Mikami	N/A	N/A	N/A	N/A	Sep-27	-	-	Dec-28
72	East Orange, Orange Heights Tract 17995 SS, RW (RA with TIC)	13441/13442	8352	Development & Pipelines	Rios	Kuan	Completed	-	In-Process	Proactive	N/A	N/A	N/A	N/A	Sep-27	-	-	Dec-28
73	Water Quality Laboratory Remodel Study	Op Budget	N/A	Infrastructure Planning	Akiyoshi	Edwards	In-Process	Jan-27	N/A	Austin Company	-	-	-	-	N/A	-	-	N/A
74	Condition Assessment Plan for DRWF Pipeline	12564	N/A	Infrastructure Planning	Akiyoshi	Robinson	In-Process	Jun-26	Jul-26	-	-	-	-	-	Jul-27	-	-	Jul-28
75	BWTP Chemical Building Shower/Eyewash Pipe Lining	BWTP Op Budget	8442	Infrastructure Planning	Akiyoshi	Jaramillo	Completed	-	Completed	In-House	Completed	Completed	Completed	Completed	In-Process	ePipe	Jun-26	Jul-26
76	EI Modena NTS Improvements	05406	8434	Future	Moeder	Lu	-	-	-	-	-	-	-	-	-	-	-	-
77	Syphon Reservoir Off Site Mitigation	13519	8411	Future	Moeder	Moeder	-	-	-	-	-	-	-	-	-	-	-	-
78	Sand Canyon Dam Spillway Rehabilitation	12505	8466	Future	Moeder	Sanchez	-	-	-	-	-	-	-	-	-	-	-	-
79	Chapman Tank Rehabilitation	12569	8330	Future	Moeder	Mwe	-	-	-	-	-	-	-	-	-	-	-	-
80	Wells 1, 2, 4, 10, 11, and 18 Site Improvements	12620		Future	Waite	Burk	-	-	-	-	-	-	-	-	-	-	-	-
81	Lake Forest Zone 4-5 West Pump Station Rehabilitation	12566		Future	Waite	Ovcharenko	-	-	-	-	-	-	-	-	-	-	-	-
82	Turtle Rock Zone 3-4 Pump Station Rehabilitation	12567		Future	Waite		-	-	-	-	-	-	-	-	-	-	-	-
83	Biosolids Gas System Modifications	13225		Future	Waite	Murphy	Aug-26	-	-	-	-	-	-	-	-	-	-	-
84	DRWF Well 2 and IDP Well 107R Rehabilitation	13255/13254		Future	Waite	Foo	-	-	-	-	-	-	-	-	-	-	-	-
85	MWRP & Biosolids Coating Repairs			Future	Future		-	-	-	-	-	-	-	-	-	-	-	-
86	MWRP Headwork Compactor Room Crane Improvements			Future	Future		-	-	-	-	-	-	-	-	-	-	-	-
87	MWRP Secondary Skimming Improvements			Future	Waite		-	-	-	-	-	-	-	-	-	-	-	-
88	LAWRP Tertiary Filter Piping Replacement			Future	Waite	Ovcharenko	-	-	-	-	-	-	-	-	-	-	-	-
89	Warner Avenue RW Pipeline Replacement			Future	Rios	Ige	-	-	-	-	-	-	-	-	-	-	-	-
90	University Park DW Pipeline Replacement Phase 1			Future	Rios		-	-	-	-	-	-	-	-	-	-	-	-
91	Portola Springs DW and RW Pipeline Rehabilitation			Future	Rios		-	-	-	-	-	-	-	-	-	-	-	-
92							-	-	-	-	-	-	-	-	-	-	-	-
93							-	-	-	-	-	-	-	-	-	-	-	-
94							-	-	-	-	-	-	-	-	-	-	-	-
95							-	-	-	-	-	-	-	-	-	-	-	-

May 19, 2026  
Prepared by: J. Colston  
Submitted by: K. Burton  
Approved by: Paul A. Cook *PAK*

## ENGINEERING AND OPERATIONS COMMITTEE

### IRWD RESEARCH BUSINESS PLAN UPDATE

#### SUMMARY:

Staff will provide an update on the research projects in which IRWD is currently involved.

#### BACKGROUND:

Periodically, IRWD receives requests to participate in various research projects pertaining to emerging technologies through either direct funding or dedication of in-kind staff resources. Guidelines were developed to assist staff with their evaluation and response to those requests. These guidelines were incorporated into the IRWD Research Business Plan, which also provides a tracking mechanism for the various requests and ongoing research projects and programs in which IRWD participates. The Research Business Plan ensures that IRWD's research resources are being prioritized and utilized effectively.

One of the components of the Research Business Plan is for staff to provide a status update on the research projects to the Engineering and Operations Committee on a quarterly basis. IRWD actively participates in the Technology Approval Group (TAG) sponsored by Isle Utilities. The TAG hosts numerous developing technology providers in order to match interested agencies with their technologies. The following are projects of interest to IRWD undertaken by the Water Research Foundation, and we are actively following them for potential benefits to IRWD:

- Water Utility Resilience: A Case Study of the 2021 Marshall Fire;
- Studying the Fate of PFAS through Sewage Sludge Incinerators;
- Developing an Environmental, Social, and Governance Framework for Water Utilities;
- Treatment Strategies for the Removal of Lithium from Drinking Water;
- CalVal Phase 1 Technical Survey: Evaluating Treatment Credits and Compliance Pathways for Indirect Potable Reuse in California; and
- Defining Exposures of Microplastics/Fibers in Treated Waters and Wastewaters: Occurrence, Monitoring, and Management Strategies.

The following research item has not changed in status since the last report:

- UCI / CDC Sponsored PFAS Epidemiological Study – UCI conducted a Centers for Disease Control (CDC) sponsored study of health impacts from the public drinking potable water tainted with Per- and Poly-fluoroalkyl substances (PFAS). Researchers added a PFAS Child Immune Study to this research. The data collection portion of the research has been completed. The data has been reviewed, and numerous scholarly manuscripts are under production. One recent manuscript with summary data is *Multi-site study of communities with PFAS-contaminated drinking water: Methods,*

*demographics, and PFAS serum concentrations.* Staff participated in a webinar hosted by the CDC to review the nationwide results. This research is complete, but the report writing is ongoing.

More research papers are expected in the coming months.

A summary of the current research projects is attached as Exhibit “A”.

FISCAL IMPACTS:

Not applicable.

ENVIRONMENTAL COMPLIANCE:

Not applicable.

RECOMMENDATION:

Receive and file.

LIST OF EXHIBITS:

Exhibit “A” – Research Projects Summary

Exhibit "A"

**Research Projects Summary Table**

No.	Project Title	Project Description	IRWD Contact	Organizations Involved	Type of Research	IRWD Participation Resource	Start Date	Projected Completion Date
1	UCI CDC Sponsored PFAS Epidemiological Study	UCI is conducting a Centers for Disease Control (CDC) sponsored study of health impacts from the public drinking potable water. Due to localized PFAS contamination in some Orange County drinking water sources, the CDC is sponsoring research to determine potential public health effects. IRWD's Irvine service area is seen as an ideal control population due to the lack of PFAS in IRWD's served potable water.	Colston	UCI, OCWD, IRWD, CDC	Epidemiological that seeks 1,000 adults and 300 children for blood serum level testing.	Assistance in determining historic sources of drinking water in IRWD's service area.	Jan-23	Dec-25

Note: This page is intentionally left blank.

May 19, 2026

Prepared by: T. Edwards / E. Akiyoshi

Submitted by: K. Burton

Approved by: Paul A. Cook 

## ENGINEERING AND OPERATIONS COMMITTEE

### FY 2026-27 PIPELINE REPLACEMENT PROJECT ADDITIONS

#### SUMMARY:

IRWD's new pressure pipeline risk model was used to create and prioritize new capital improvement projects for FY 2026-27 to support its level of service goals. The projects below includes approximately three miles of pipeline replacements. These projects reduce total system risk, with the goal of staying with IRWD's annual break rate – defined as “breaks per 100-miles” (BPHM) – service levels by targeting the highest likelihood of failure pipelines.

Staff recommends that the Board:

- Authorize the addition of the Warner Avenue Recycled Water Pipeline Replacement, Project 13560 in the amount of \$2,310,000 to the FY 2026-27 Capital Budget;
- Authorize the addition of the Portola Springs Domestic Water Pipeline Rehabilitation, Project 13561 in the amount of \$3,778,000 to the FY 2026-27 Capital Budget;
- Authorize the addition of the Portola Springs Recycled Water Pipeline Rehabilitation, Project 13562 in the amount of \$3,512,000 to the FY 2026-27 Capital Budget; and
- Authorize the addition of the University Park Domestic Water Pipeline Replacement, Project 13563 in the amount of \$4,480,000 to the FY 2026-27 Capital Budget.

#### BACKGROUND:

In 2026, IRWD completed the Capital Improvement Plan and Asset Management for Domestic and Recycled Water Pipelines Project, which included a new risk model to assist with the identification and prioritization of capital projects. Additionally, IRWD seeks to stay within its current pipe break rate level of service (i.e., two BPHM for the domestic system and six BPHM for the recycled system).

A general pipeline replacement plan was developed for the next 30 years based on the risk model and level of service goals. The pipeline replacement program consists of three miles of pipeline for the next five years, six miles of pipeline per year for the following 10 years, and nine miles of pipeline per year for the following 15 years. The risk model was used to prioritize and identify three miles of pipelines for replacement and package the pipelines into projects.

To achieve these goals, staff is recommending that the District proceed with the following four pipeline replacement projects: the Warner Avenue, Portola Springs (Domestic and Recycled Water), and University Park pipeline replacements. A location map of these four projects is provided as Exhibit “A.”

FISCAL IMPACTS:

Staff recommends the addition of Projects 13560, 13561, 13562, and 13563, which will be funded by the respective Domestic Water and Recycled Water Replacement Funds, to the FY 2026-27 Capital Budget as follows:

<u>Project No.</u>	<u>Current Budget</u>	<u>Addition &lt;Reduction&gt;</u>	<u>Total Budget</u>
13560	\$0	\$2,310,000	\$2,310,000
13561	\$0	\$3,778,000	\$3,778,000
13562	\$0	\$3,512,000	\$3,512,000
13563	\$0	\$4,480,000	\$4,480,000
Total	\$0	\$14,080,000	\$14,080,000

ENVIRONMENTAL COMPLIANCE:

The Projects are subject to the California Environmental Quality Act (CEQA). In conformance with the California Code of Regulations Title 14, Chapter 3, Section 15004, the appropriate environmental document(s) will be prepared when "meaningful information" becomes available.

RECOMMENDATION:

That the Board authorize the addition of the Warner Avenue Recycled Water Pipeline Replacement, Project 13560 in the amount of \$2,310,000 to the FY 2026-27 Capital Budget; authorize the addition of the Portola Springs Domestic Water Pipeline Rehabilitation, Project 13561 in the amount of \$3,778,000 to the FY 2026-27 Capital Budget; authorize the addition of the Portola Springs Recycled Water Pipeline Rehabilitation, Project 13562 in the amount of \$3,512,000 to the FY 2026-27 Capital Budget; and authorize the addition of the University Park Domestic Water Pipeline Replacement, Project 13563 in the amount of \$4,480,000 to the FY 2026-27 Capital Budget.

LIST OF EXHIBITS:

Exhibit "A" – Location Map

Exhibit "A"

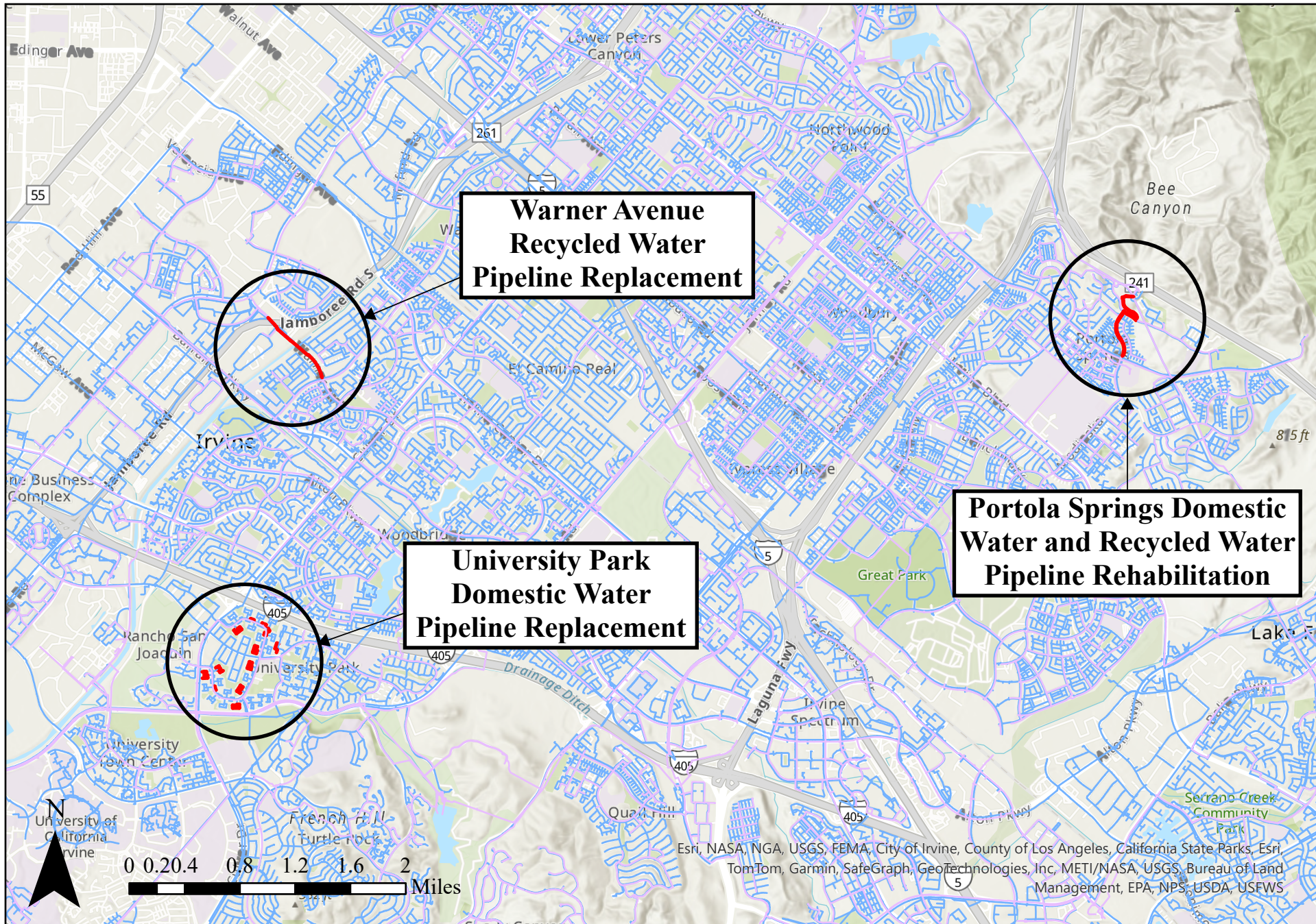

# FY 2026-27 PIPELINE PROJECT ADDITIONS LOCATION MAP

Note: This page is intentionally left blank.

May 19, 2026  
Prepared by: M. Robinson / E. Akiyoshi  
Submitted by: K. Burton  
Approved by: Paul A. Cook *ACA*

ENGINEERING AND OPERATIONS COMMITTEE

FISCAL YEARS 2025-26 GENERAL REPLACEMENTS AND MODIFICATIONS  
PROJECTS BUDGET INCREASES

SUMMARY:

The Fiscal Year (FY) 2025-26 General System Replacements and Modifications projects have experienced increased spending associated with small construction projects, pipeline repairs, and general mechanical, electrical, and construction services expenditures.

Staff recommends that the Board:

- Authorize a budget increase to Project 12521, FY 2025-26 Domestic Water General System Replacements and Modifications, in the amount of \$1,417,000, from \$6,283,000 to \$7,700,000;
- Authorize a budget increase to Project 12523, FY 2025-26 Recycled Water General System Replacements and Modifications, in the amount of \$497,000, from \$2,103,000 to \$2,600,000; and
- Authorize a budget increase to Project 12525, FY 2025-26 Sewer General System Replacements and Modifications, in the amount of \$1,315,000, from \$1,785,000 to \$3,100,000.

BACKGROUND:

The General System Replacements and Modifications projects encompass a variety of capital activities, including small construction projects at MWRP and the Biosolids Facilities, emergency pipeline repairs, mechanical and electrical asset replacements, industrial coatings repairs, meter upgrades, and reimbursement for raising valves and manholes to grade following city street rehabilitation projects. Due to increased activity and expenditures in FY 2025-26, staff recommends budget increases of \$1,417,000 for Project 12521, \$497,000 for Project 12523, and \$1,315,000 for Project 12525.

FISCAL IMPACTS:

Projects 12521, 12523, and 12525 are included in the FY 2025-26 Capital Budget and require budget increases as follows:

Project No.	Current Budget	Addition <Reduction>	Total Budget
12521	\$6,283,000	\$1,417,000	\$7,700,000
12523	\$2,103,000	\$497,000	\$2,600,000
12525	\$1,785,000	\$1,315,000	\$3,100,000
Total	\$10,171,000	\$3,229,000	\$13,400,000

ENVIRONMENTAL COMPLIANCE:

This study is exempt from the California Environmental Quality Act as authorized under the California Code of Regulations, Title 14, Chapter 3, Section 15262 which provides exemption for planning studies.

RECOMMENDATION:

That the Board authorize a budget increase for Project 12521 in the amount of \$1,417,000, from \$6,283,000 to \$7,700,000; authorize a budget increase for Project 12523 in the amount of \$497,000, from \$2,103,000 to \$2,600,000; and authorize a budget increase for Project 12525 in the amount of \$1,315,000, from \$1,785,000 to \$3,100,000, for the Fiscal Year 2025-26 General System Replacements and Modifications projects.

LIST OF EXHIBITS:

None.

May 19, 2026

Prepared by: A. Murphy / B. Waite

Submitted by: K. Burton

Approved by: Paul A. Cook 

## ENGINEERING AND OPERATIONS COMMITTEE

### MICHELSON WATER RECYCLING PLANT SOLIDS HANDLING IMPROVEMENTS VARIANCE AND BUDGET INCREASE

#### SUMMARY:

The Michelson Water Recycling Plant (MWRP) Solids Handling Improvements project will address mechanical and performance issues with the solids thickening and dewatering processes.

Staff recommends that the Board:

- Authorize a budget increase for Project 12555 in the amount of \$10,670,000, from \$1,065,000 to \$11,735,000, and
- Authorize the General Manager to approve Variance No. 1 with Carollo Engineers, Inc. in the amount of \$394,974 for additional engineering design services for the MWRP Solids Handling Improvements.

#### BACKGROUND:

IRWD's MWRP Biosolids Facility was commissioned and put into operation in the fall of 2020. Since then, staff have discovered operational, performance, and maintenance issues related to the thickening and dewatering processes. In May 2022, IRWD retained Carollo Engineers, Inc. to study the solids handling facility issues. The study documented issues faced by staff, identified potential causes, and developed solutions to implement to address these issues.

In October 2022, Carollo documented the study findings and recommendations in a technical memorandum. The key recommendations included improving the sludge feed consistency, increasing the thickened sludge concentration to the digesters, upsizing the digester feed pumps to handle thicker sludge, reducing clogging in the sludge lines, improving centrate drainage to protect dewatering centrifuges, and improvements to increase process instrumentation reliability.

In June 2025, IRWD retained Carollo to design the recommended Biosolids Facility Improvements. The scope of the design includes preparing drawings, technical specifications, and a project manual for construction bidding. Carollo has completed the preliminary design of the Project and will be submitting the 60% final design this month. To date, Carollo has spent approximately 80% of their current budget.

#### Design Agreement Variance No. 1:

During the preliminary design phase, it was discovered by staff that some changes to the original project scope were required to meet the overall Project objectives. The significant additional design elements are described as follows:

Engineering and Operations Committee: Michelson Water Recycling Plant Solids Handling Improvements Variance and Budget Increase

May 19, 2026

Page 2

- Add overflow protection and inter-tank opening slide gates to the primary sludge and waste activated sludge wet wells;
- Add electrically actuated valves for sludge recirculation; and
- Replace the Methane Phase Digester Recycled pumps.

Slide gates and overflow protection were added for the primary sludge, blended sludge and waste activated sludge wet wells to allow for safer operation and maintenance access while maintaining process flow. Electrically actuated valves were proposed for the sludge recirculation process instead of manual valves for ease of operation, reduction of staff time and to ensure all valves are operated correctly during sludge recirculation. Replacement of the Methane Phase Digester Recycle pumps was added because the pumps are obsolete and the manufacturer no longer supports the existing pump model to provide replacement of parts.

Work that is to be eliminated from the scope includes removing unnecessary field work and potholing, reducing the number of meetings, and the deleting proposed SCADA screen mockup related to the original System Simplification scope.

The proposed changes to the design scope of work are necessary to meet the operational and maintenance requirements and ensure safe, long-term operability and reliability for the Biosolids Facility. The proposed design changes will modify 45 drawings and require 30 additional drawings, increasing the design schedule by three months. The revised schedule shows the final design submittal will be provided in October 2026. The negotiated total cost of Variance No. 1 is \$394,974 and it is provided as Exhibit "A". Staff has reviewed the negotiated variance cost proposal and scope of work and determined it to be fair and reasonable.

FISCAL IMPACTS:

Project 12555 is currently included in the FY 2025-26 Capital Budget. This project is funded 50% by Sewer Replacement Funds and 50% by Sewer New Capital funds. A budget increase is required to fund the design and construction phases as shown in the table below:

Project No.	Current Budget	Addition <Reduction>	Total Budget
12555	\$ 1,065,0000	\$ 10,670,000	\$11,735,000

ENVIRONMENTAL COMPLIANCE:

This project is subject to the California Environmental Quality Act (CEQA). In conformance with the California Code of Regulations Title 14, Chapter 3, Section 15004, the appropriate environmental document will be prepared when "meaningful information" becomes available. It is expected that preliminary analysis will lead to the preparation of a Notice of Exemption for the project as authorized under the California Code of Regulations, Title 14, Chapter 3, Section 15301 which provides exemption for minor alterations of existing public or private structures, facilities, mechanical equipment, or topographical features, involving negligible or no expansion of use beyond that existing at the time of the lead agency's determination.

Engineering and Operations Committee: Michelson Water Recycling Plant Solids Handling  
Improvements Variance and Budget Increase

May 19, 2026

Page 2

RECOMMENDATION:

That the Board authorize a budget increase in the amount of \$10,670,000, from \$1,065,000 to \$11,735,000, and authorize the General Manager to approve Variance No. 1 with Carollo Engineers, Inc. in the amount of \$394,974 for additional engineering design services for the Michelson Water Recycling Plant Solids Handling Improvements, Project 12555.

LIST OF EXHIBITS:

Exhibit "A" – Carollo Variance No. 1

Note: This page is intentionally left blank.

Exhibit "A"  
**IRVINE RANCH WATER DISTRICT**  
**PROFESSIONAL SERVICES VARIANCE**

Project Title: Irvine Ranch Water District Solids Handling Improvements Project  
 Project No.: 12555 Date: 4/27/2026  
 Purchase Order No.: \_\_\_\_\_ Variance No.: 1

Originator: [ ] IRWD [X] ENGINEER/CONSULTANT [ ] Other (Explain) \_\_\_\_\_

Description of Variance (*attach any back-up material*):

A combination of added and deducted scope from the solids handling improvements project. Major additive elements include:  
Overflow and gates for PS/WAS Wetwells, feasibility assessment of PS/WAS hatches, electrical actuators for sludge recirculation,  
Replacing methane phase digested sludge recycle pumps, recycle water improvements, and wharf hydrants for centrate SBR.

Engineering & Management Cost Impact:

Classification	Manhours	Billing Rate	Labor \$	Direct Costs	Subcon. \$	Total \$
Project Management	107	274.69	29,392	100	0	29,492
Preliminary Design Report	568	236.14	134,129	-100	-19,391	114,638
Final Design	1079	232.48	250,844	0	0	250,844
<b>Total \$ =</b>						<b>394,974</b>

Schedule Impact:

Task No.	Task Description	Original Schedule	Schedule Variance	New Schedule
2	Preliminary Design Report	11/3/2025	130 calendar days	3/13/2026
3	Final Design	6/15/2026	112 calendar days	10/5/2026
4	Bid Period Support	8/3/2026	120 calendar days	12/1/2026

Required Approval Determination:

Total Original Contract	<u>\$1,052,221</u>	[ ] Director: Cumulative total of Variances less than or equal to \$75,000.
Previous Variances \$0		
This Variance	<u>\$394,974</u>	[ ] Executive Director: Cumulative total of Variances less than or equal to \$125,000.
Total Sum of Variances	<u>\$394,974</u>	
New Contract Amount	<u>\$1,447,195</u>	[ ] General Manager: Cumulative total of Variances less than or equal to \$200,000.
Percentage of Total Variances to Original Contract	<u>38 %</u>	[X] Board: Cumulative total of Variances greater than \$200,000.

ENGINEER/CONSULTANT: Carollo Engineers, Inc  
 Company Name

IRVINE RANCH WATER DISTRICT

Rashi Gupta  
Rashi Gupta (Apr 28, 2026 19:01:23 PDT)  
 Project Engineer/Manager

Apr 28, 2026  
 Date

Kevin L. Burton A.M.  
 Department Director 5/11/26  
 Date

Eric M. Mills  
 Engineer's/Consultant's Management  
 Eric M. Mills

Apr 28, 2026  
 Date

General Manager/Board \_\_\_\_\_  
 Date





## Scope of Work

### Irvine Ranch Water District Task Order No. 2 – Solids Handling Improvements Project Amendment

#### BACKGROUND

Irvine Ranch Water District (DISTRICT) has requested changes to the original scope of work for the Michelson Water Reclamation Plant (MWRP) Solids Handling Improvement Project Task Order No.1 (TO1). Some changes are deductive and some are additive. The requested changes comprise Task Order No.2 (TO2) and are summarized below:

#### Deductive:

- Conducting two, four-hour, site visit to interview staff and gather more information on the operations of the solids systems to enable the ENGINEER to suggest system simplification strategies.
- Preparing one SCADA screen mockup to show a more tangible example of SCADA simplification suggestions that would be made by the ENGINEER.
- Scaffolding effort provided by IRWD staff, instead of Jamison Engineering Contractors, during V&A's centrate pipe inspection
- Potholing effort by Underground Solutions Inc.
- Remaining effort for the detailed design of the digester gas condensate modifications.

#### Additive:

- Adding the following provisions to the scope of the PS/WAS wet wells modifications:
  - Adding overflow protection to each wet well.
  - Isolating inter-tank openings with manual gates.
  - Routing the existing WAS centrate pipe to an additional wet well.
  - Isolating the existing TS wet well overflow piping with a manual valve.
- Assessing the feasibility of providing access hatches at the PS/WAS wet wells.
- Providing electrically actuated valves, rather than manual valves, to enable automated backflushing for the acid digester feed piping.
- Installing isolation valves and pressure gauges at each of the thickening and dewatering centrifuges recycle water (RW) feed pipes.
- Replacing obsolete Methane Phase Digester Recycle pumps with new model (2000 series).
- Developing PS/WAS wet wells' mixers replacement cost.
- Evaluating whether 120V valves can be used to actuate sludge recirculation valves instead of 480V, which is the standard.
- Addition of two wharf hydrants and associated water piping at the centrate SBRs to facilitate hose down/housekeeping.

- Upsizing existing slop flush lines to 1.5" (includes upsizing the solenoid valves) at the three dewatering centrifuges.
- Developing (3) Process Flow Diagram (PFD) drawings to facilitate staff understanding of the system.
- Conducting a Programming Review Meeting at 90% design to discuss programming modifications with DISTRICT staff.

ENGINEER estimates that TO2, will add 30 new sheets and add additional information to 45 sheets. A complete list of the two sets of drawings is presented in Appendix A: New Drawings resulting from TO2, and Drawings impacted by TO2.

Below are more detailed descriptions of the deductive items for which the project will be credited and the additive items that comprise the scope of work for TO2.

### **PROJECT CREDIT FOR DEDUCTIVE ITEMS**

The original scope of *Task Order 1: Task 2 Preliminary Design, Subtask 206 Improvements Recommendations - System Simplification and Dryer System Reliability* included:

1. Conducting three, four-hour, site visits to interview staff and collect more information on the operations of the solids systems (both at the field, and through SCADA) in order for ENGINEER to suggest simplification strategies.
2. Preparing one SCADA screen mockup to show a more tangible example of SCADA simplification suggestions that would be made by ENGINEER.

ENGINEER conducted only one of the planned site visits. ENGINEER did not conduct two site visits since it was not necessary. Additionally, the DISTRICT informed ENGINEER that they did not wish to have another SCADA site visit/discussion and directed ENGINEER not to prepare the SCADA mockup. This effort is delineated in the following subtasks:

- Task 202: Site Visits, Staff Feedback, and Documentation Review
- Task 206A: Improvements Recommendations - System Simplification and Dryer System Reliability (SCADA Mockup)

During preliminary design, Carollo contracted the service of two subconsultants: V&A to conduct pipe inspection on the centrate pipes, and Underground Solutions to pothole the condensate and centrate pipes areas. V&A intended to use a subcontractor, Jamison Engineering Contractors, to provide scaffolding to access the centrate pipes during pipe inspection. Instead, V&A used scaffolding erected by IRWD staff and did not need to utilize Jamison Engineering Contractors. Additionally, the ENGINEER and the DISTRICT decided that potholing was not necessary to construct the new centrate and condensate pipes. The credit associated with the unused balance from V&A's contract along with the full balance from Underground Solutions, including ENGINEER'S 5% markup, is delineated in the following subtask:

- Task 205: Improvements Recommendations - Field Investigations

On 4/3/26, the DISTRICT requested that the digester gas condensate modifications portion of the project is removed from the scope. Effort associated with the preliminary design as well as a portion of

the 60% design has been expended. The credit associated with the remaining portion of 60% design, as well as the full 90% and final design efforts is delineated in the following subtask:

- Tasks 303-305: Digester Gas Condensate Modifications

### **SCOPE OF WORK FOR ADDITIVE BASE ITEMS**

The scope of work associated with the additive items in TO2 is summarized below.

#### **TASK 1 – PROJECT MANAGEMENT**

The ENGINEER will perform various project management and monitoring activities throughout the Project duration, as delineated in the following subtasks.

- Tasks 104 and 105: The project schedule has been extended by 3 months. Project management activities, including additional biweekly and monthly progress reports and team management are necessary. This task includes additional effort associated with those activities as described in TO1.
- 106: Programming Review Meeting – During the 90 percent design stage, ENGINEER will present to the DISTRICT major changes to the programming logic resulting from the new control strategies. The purpose of this meeting is to provide DISTRICT staff with an additional opportunity to review the programming changes, engage with ENGINEER, and provide feedback prior to final design.

#### Task 1 Deliverables:

- As presented in Task Order 1.
- Programming Review Meeting agenda and minutes (PDF format).

#### Assumptions:

- Programming Review Meeting will be 2 hours in duration and up to four (4) team members will participate in the meeting. Meeting will be hybrid.

#### **TASK 2 – PRELIMINARY DESIGN REPORT (PDR)**

The ENGINEER updated the PDR to include:

- The following PS/WAS wet wells modifications:
  - Adding overflow protection to each wet well.
  - Isolating inter-tank openings with manual gates.
  - Routing the existing WAS centrate pipe to an additional wet well.
  - Isolating the existing TS wet well overflow piping with a manual valve.
- Feasibility assessment of access hatches at the PS/WAS wet wells.
- Electrically actuated valves in sludge recirculation loop.
- Isolation valves and pressure gauges at each of the thickening and dewatering centrifuges RW feed pipes.
- Replacement of obsolete Methane Phase Digester Recycle pumps with new model (2000 series).

- Evaluation of whether 120V valves can be used to actuate sludge recirculation valves instead of 480V, which is standard for the size valves to be actuated. Evaluation included consultation with valve and actuator manufacturers as well as internal experts to assess suitability and risks because 120 V actuators are not typically used for 4” and 8” plug valves.

The preliminary design effort is delineated in the following subtasks for clarity:

- Task 204: Improvements Recommendations
- Task 212: Feasibility Assessment of Adding Hatches at PS/WAS Wet Wells

There was an additional task that DISTRICT requested the ENGINEER complete that was not part of the PDR, which is:

- Evaluating PS/WAS wet wells’ mixers replacement cost.

Effort for this task is included in the following subtask:

- Task 204: Improvements Recommendations

Task 2 Deliverables:

As presented in Task Order 1.

Assumptions:

- Preliminary design drawings will not include PS/WAS Wet Well hatches.

**TASK 3 – FINAL DESIGN**

The ENGINEER will include the following scope additions in the final design documents:

- The following PS/WAS wet wells modifications:
  - Adding overflow protection to each wet well.
  - Isolating inter-tank openings with manual gates.
  - Routing the existing WAS centrate pipe to an additional wet well.
  - Isolating the existing TS wet well overflow piping with a manual valve.
- Isolation valves and pressure gauges at each of the thickening and dewatering centrifuges recycle water (RW) feed pipes.
- Replacement of obsolete Methane Phase Digester Recycle pumps with new model (2000 series).
- Addition of two wharf hydrants and associated water piping at the centrate SBRs to facilitate hose down/housekeeping.
- Providing electrically actuated valves, rather than manual valves, to enable automated backflushing for the acid digester feed piping.
- Upsizing the existing slop flush lines to 1.5” (includes upsizing the solenoid valves) at the three dewatering centrifuges. See assumptions for critical assumptions for this task.
- Developing (3) Process Flow Diagram drawings to assist with staff understanding of overall systems.

The final design effort is delineated in the following subtasks.

- Task 303 60% Draft Submittal
- Task 304 90% Design Submittal
- Task 305 Final Design Submittal

### Task 3 Deliverables:

As presented in Task Order 1.

### Assumptions:

- The following assumptions apply to the hydrant, and associated water piping to facilitate washdown and housekeeping at the centrate SBRs:
  - Provisions will consist of a new 4" Utility Water (UW2) exposed pipe connecting into an existing 6" UW2 pipe located in the polymer feeder/blender area in the SHB. The new UW2 pipe will feed two 2 ½" wharf head hydrants, located on each side of the deck, and intended for cleaning and hosing down of tanks and pit. Temporary hoses, provided by the DISTRICT, would be used to connect to the hydrant.
  - No potholing is required since civil as-built drawings do not show any buried utilities or pipes between the yard connection and the centrate SBRs.
  - Plumbing drawings will not be produced. Modifications will be captured on civil and process/mechanical drawings only.
  - All provisions are manual.
  - Sufficient water pressure is available. No booster pumps will be required.
  - Sufficient water supply is available to cover other processes connected into the existing 6" UW2 pipe when the hydrant is being used to fully clean the tanks.
  - No backflow preventers will be needed.
- The following assumptions apply to the RW modifications:
  - New valves are assumed to be manual valves with no limit switches. No additional electrical or instrumentation drawing are assumed.
  - Some of the existing RW piping is shown on the plumbing plan drawings and some RW piping is shown on the mechanical drawings in MWRP Biosolids and Energy Recovery Facility as-builts. For simplicity, ENGINEER will show all RW modifications on mechanical drawings only.
  - The RW modifications are assumed to consist of 1 isolation valve and 1 pressure gauge at the thickening and dewatering centrifuges RW headers (7 locations: 4 at the thickening centrifuges, and 3 at the dewatering centrifuges) in the drawings assumed for this project.
- The following are Electrical, Instrumentation and Controls related assumptions:
  - Methane Phase Digested Sludge Recycle Pump VFDs will not be replaced.
  - New cable and conduit schedule drawings will be submitted to capture the new work. Original as-built drawings showing cable and conduit schedules that do not contain new work will not be modified.
  - Original MCC elevation as-built drawings will not be modified. The labels on the as-built MCC elevation drawings do not accurately reflect field labels and it will be a significant

effort to correct them. These drawings are not critical for the planned modifications. No corrections to existing bucket designations are included. Drawings will be used to show changes to MCC elevations using photos.

- No single line demolition drawings are included. Electrical single line drawings are sufficient to show the electrical scope.
- Discrepancies between existing as-built drawings and field conditions will not be corrected on drawings if corrections do not impact new work.
- Panels' bill of material (BOM) drawings will show items and quantities related to the new work only for clarity.
- No effort to correct as-builts to match field conditions if corrections do not affect the current design or the Contractor's work.
- Process flow diagrams (PFDs) are intended to be simplified schematics including only essential information for overall process understanding. Not all valves, flush locations, etc. will be shown on the PFDs. However, the P&IDs included in the base project will reflect these details.
- No P&IDs are included for the upsizing of the 1.5-inch slop line solenoid valves. All work will be done on the mechanical, electrical (conduit) and area plan drawings to show the new solenoid and the replacement of the wiring.

## **SCHEDULE**

The project schedule is updated to the following:

- Draft PDR (to DISTRICT): 1/30/2026
- Final PDR (to DISTRICT): 3/13/2026
- 60% Design Submittal (to DISTRICT): 5/11/2026
- 90% Design Submittal (to DISTRICT): 8/10/2026
- Final Design Submittal (to DISTRICT): 10/5/2026
- Bid Opening: 12/1/2026

## **ESTIMATED EFFORT**

As shown in Exhibit A:

- Effort already expended on TO2 items through the PDR stage is \$114,638
- The base fee for this Task Order No.2 is \$394,974.

## **OTHER ASSUMPTIONS**

In addition to the assumptions noted within the Scope of Work above, the following assumptions have been made in developing this Scope of Work and associated level of effort:

- One DISTRICT point of contact (POC) made available and accessible to ENGINEER staff throughout project duration.
- DISTRICT staff may be asked to provide existing system information (performance data, standard operating procedures, schematics, drawings, existing equipment information, etc.), clarification on items that are unclear and to provide photographs or additional information on select items if needed.

- DISTRICT shall furnish ENGINEER available studies, reports and other data pertinent to ENGINEER's services; obtain or authorize ENGINEER to obtain or provide additional reports and data as required; furnish to ENGINEER services of others required for the performance of ENGINEER's services hereunder, and ENGINEER shall be entitled to use and rely upon all such information and services provided by DISTRICT or others in performing ENGINEER's services under this Agreement.
- ENGINEER has no control over the cost of labor, materials, equipment or services furnished by others, over the incoming water quality and/or quantity, or over the way DISTRICT's plant and/or associated processes are operated and/or maintained. Data projections and estimates are based on ENGINEER's opinion based on experience and judgment. ENGINEER cannot and does not guarantee that actual costs and/or quantities realized will not vary from the data projections and estimates prepared by ENGINEER and ENGINEER will not be liable to and/or indemnify DISTRICT and/or any third party related to any inconsistencies between ENGINEER's data projections and estimates and actual costs and/or quantities realized by DISTRICT and/or any third party in the future, except to the extent such inconsistencies are caused by ENGINEER's negligent performance hereunder.
- The services to be performed by ENGINEER are intended solely for the benefit of DISTRICT. No person or entity not a signatory to this Agreement shall be entitled to rely on ENGINEER's performance of its services hereunder, and no right to assert a claim against ENGINEER by assignment of indemnity rights or otherwise shall accrue to a third party as a result of this Agreement or the performance of ENGINEER's services hereunder.

# Appendix A

## New and Planned Drawings Impacted by T02

### New Drawings:

Sheet Count	Discipline	Sheet Title
1	General	PROCESS FLOW DIAGRAM 1 - PLANT CONNECTIONS & THICKENING
2	General	PROCESS FLOW DIAGRAM 2 - DIGESTION
3	General	SLUDGE RECIRCULATION PROCESS FLOW DIAGRAM
4	Structural	SOLIDS HANDLING BUILDING - DETAILS
5	Structural	SOLIDS HANDLING BUILDING - DETAILS
6	Electrical	SOLIDS HANDLING BUILDING - PANELBOARD SCHEDULES
7	Electrical	DIGESTER CONTROL BUILDING - PANELBOARD SCHEDULES
8	Electrical	DIGESTER CONTROL BUILDING - PANELBOARD SCHEDULES
9	Electrical	CABLE AND CONDUIT SCHEDULES 2
10	Electrical	CABLE AND CONDUIT SCHEDULES 3
11	Electrical	CABLE AND CONDUIT SCHEDULES 4
12	Electrical	SOLIDS HANDLING BUILDING - MCC ELEVATIONS
13	Electrical	DIGESTER CONTROL BUILDING - MCC-4102 ONE LINE DIAGRAMS
14	Electrical	DIGESTER CONTROL BUILDING - MCC-4102 ONE LINE DIAGRAMS (CONT.)
15	Electrical	DIGESTER CONTROL BUILDING - MCC-4103 ONE LINE DIAGRAMS
16	Electrical	DIGESTER CONTROL BUILDING - MCC-4103 ONE LINE DIAGRAMS (CONT.)
17	Electrical	DIGESTER CONTROL BUILDING - MCC ELEVATIONS

18	Electrical	SCHEMATIC DIAGRAMS
19	Electrical	DIGESTER CONTROL BUILDING - GROUND LEVEL POWER PLAN 5
20	Electrical	DIGESTER CONTROL BUILDING - GROUND LEVEL POWER PLAN 6
21	Electrical	DIGESTER CONTROL BUILDING - GROUND LEVEL CONTROL AND SIGNAL PLAN 5
22	Electrical	DIGESTER CONTROL BUILDING - GROUND LEVEL CONTROL AND SIGNAL PLAN 6
23	Electrical	DIGESTER CONTROL BUILDING - BASEMENT LEVEL POWER PLAN 5
24	Electrical	DIGESTER CONTROL BUILDING - BASEMENT LEVEL CONTROL AND SIGNAL PLAN 5
25	Instrumentation	P&ID SLUDGE SCREENS
26	Instrumentation	P&ID METHANE PHASE DIGESTED SLUDGE RECYCLE PUMP
27	Instrumentation	INTERNAL PANEL ELEVATION
28	Instrumentation	RIO PANEL RIO-2002 BILL OF MATERIAL
29	Instrumentation	INTERNAL PANEL ELEVATION
30	Instrumentation	RIO PANEL RIO-3101 BILL OF MATERIAL

**Modified Drawings Impacted by TO2:**

Sheet Count	Discipline	Sheet Title
1	Civil	OVERALL YARD PIPING PLAN
2	Civil	YARD PIPING PLAN
3	Civil	CIVIL TYPICAL DETAILS 1
4	Demolition	SOLIDS HANDLING BUILDING - ENLARGED PIPING PLAN EL 36 TO 53 - AREA 3
5	Demolition	SOLIDS HANDLING BUILDING - SECTIONS
6	Demolition	SOLIDS HANDLING BUILDING - THICKENING CENTRIFUGE PLAN & SECTIONS
7	Demolition	SOLIDS HANDLING BUILDING - DEWATERING CENTRIFUGE PLAN & SECTIONS
8	Demolition	DIGESTER CONTROL BUILDING - DEMOLITION ENLARGED BASEMENT LEVEL PLAN
9	Structural	SOLIDS HANDLING BUILDING - DETAILS
10	Structural	CENTRATE TREATMENT – DETAILS

11	Mechanical	SOLIDS HANDLING BUILDING - FIRST FLOOR ENLARGED PLAN - AREA 3
12	Mechanical	SOLIDS HANDLING BUILDING - SECOND FLOOR ENLARGED PLAN - AREA 3
13	Mechanical	SOLIDS HANDLING BUILDING - SECOND FLOOR ENLARGED PLAN - AREA 4
14	Mechanical	SOLIDS HANDLING BUILDING - ENLARGED PIPING PLAN EL 30 TO 53 - AREA 2
15	Mechanical	SOLIDS HANDLING BUILDING - THICKENING CENTRIFUGE PLAN AND SECTIONS
16	Mechanical	SOLIDS HANDLING BUILDING - SECTIONS
17	Mechanical	SOLIDS HANDLING BUILDING - SECTIONS
18	Mechanical	SOLIDS HANDLING BUILDING - SECTIONS
19	Mechanical	SOLIDS HANDLING BUILDING - DETAILS
20	Mechanical	DIGESTER CONTROL BUILDING - ENLARGED BASEMENT LEVEL PLAN
21	Mechanical	DIGESTER CONTROL BUILDING - SECTION
22	Mechanical	DIGESTER CONTROL BUILDING - DETAILS
23	Mechanical	CENTRATE TREATMENT - TOP PLAN
24	Electrical	SOLIDS HANDLING BUILDING - PANELBOARD SCHEDULES
25	Electrical	CABLE AND CONDUIT SCHEDULES 1
26	Electrical	SOLIDS HANDLING BUILDING - ENLARGED FIRST FLOOR POWER PLAN 1
27	Electrical	SOLIDS HANDLING BUILDING - ENLARGED FIRST FLOOR POWER PLAN 6
28	Electrical	SOLIDS HANDLING BUILDING - ENLARGED FIRST FLOOR CTRL & SIG PLAN 1
29	Electrical	SOLIDS HANDLING BUILDING - ENLARGED FIRST FLOOR CTRL & SIG PLAN 5
30	Electrical	SOLIDS HANDLING BUILDING - ENLARGED FIRST FLOOR CTRL & SIG PLAN 6
31	Electrical	SOLIDS HANDLING BUILDING - ENLARGED SECOND FLOOR CTRL & SIG PLAN 4
32	Electrical	SOLIDS HANDLING BUILDING - ENLARGED DEWATERING CENTRIFUGE PLAN
33	Electrical	SOLIDS HANDLING BUILDING - ENLARGED DEWATERING CENTRIFUGE PLAN
34	Instrumentation	P&ID SLUDGE WETWELLS
35	Instrumentation	P&ID THICKENING CENTRIFUGE NO. 1
36	Instrumentation	P&ID THICKENING CENTRIFUGE NO. 2
37	Instrumentation	P&ID THICKENING CENTRIFUGE NO. 3
38	Instrumentation	P&ID THICKENING CENTRIFUGE NO. 4
39	Instrumentation	P&ID THICKENED SLUDGE WETWELL
40	Instrumentation	P&ID DIGESTER FEED PUMPS (SHEET 1 OF 4)
41	Instrumentation	P&ID DIGESTER FEED PUMPS (SHEET 2 OF 4)
42	Instrumentation	P&ID DIGESTER FEED PUMPS (SHEET 3 OF 4)

<b>43</b>	Instrumentation	P&ID DIGESTER FEED PUMPS (SHEET 4 OF 4)
<b>44</b>	Instrumentation	P&ID ACID PHASE DIGESTER NO. 1 SLUDGE FEED, MIXING AND LOCAL GAS
<b>45</b>	Instrumentation	P&ID ACID PHASE SLUDGE TRANSFER PUMPS



May 19, 2026

Prepared by: M. Alvarez / B. Waite

Submitted by: K. Burton

Approved by: Paul A. Cook 

## ENGINEERING AND OPERATIONS COMMITTEE

### EAST IRVINE ZONE 3-4 PUMP STATION REHABILITATION CONSULTANT SELECTION AND BUDGET ADJUSTMENT

#### SUMMARY:

IRWD is undertaking the East Irvine Zone 3-4 Pump Station Rehabilitation project to address aging, unreliable, and obsolete mechanical, electrical, and controls infrastructure at this critical facility. The project will improve long-term reliability and maintainability by increasing the useful life of this pump station.

Staff recommends that the Board:

- Authorize a budget increase for Project 12565 in the amount of \$3,780,000, from \$2,500,000 to \$6,280,000, and
- Authorize the General Manager to approve a Professional Services Agreement with Jacobs in the amount of \$938,942 for engineering design services for the East Irvine Zone 3-4 Pump Station Rehabilitation.

#### BACKGROUND:

The East Irvine Zone 3 to 4 Pump Station is an above-grade, outdoor, domestic water pump station located on Alton Parkway in the City of Irvine. The station conveys water from the adjacent Zone 3 Reservoirs to the Zone 4 system and plays a critical role in maintaining reliable water service.

The facility's mechanical, electrical and control systems are over 35 years old and have experienced ongoing operational challenges. These issues have contributed to reduced reliability and premature failure of the pumps resulting in no pumping redundancy. Currently, only two of the four pumps are in service with one of the pumps undergoing rehabilitation. Overall, the station's equipment has reached or exceeded its expected service life and has continued to degrade due to long-term exposure to outdoor conditions.

This project will evaluate options to rehabilitate or replace aging equipment to improve system reliability and performance. Mechanical pumps and electrical and control systems are anticipated to be replaced while associated mechanical piping, surge tank and appurtenances will be evaluated through a condition assessment to determine the appropriate level of rehabilitation or replacement. The project will also evaluate site security improvements to enhance safety and reduce the potential for break-ins. A key priority for this project will be minimizing service disruptions during construction through careful planning, temporary power provisions, and coordination with staff and Southern California Edison. The selected consultant will prepare bid-ready construction documents along with a supporting construction cost estimate and schedule in accordance with District standards.

Consultant Selection Process:

IRWD issued a Request for Proposals for engineering design services to five design firms: Brown and Caldwell, HDR, Jacobs, MKN, and WHB Engineers. Proposals were received from Brown and Caldwell, HDR, Jacobs, and WHB Engineers. The remaining firm declined to submit a proposal citing workload and schedule constraints.

Staff evaluated the proposals received and determined that Jacobs submitted the best proposal by addressing the project objectives. Jacobs proposed a highly qualified and experienced team with all core team members located in its Irvine office. Jacobs' project understanding and approach included a well-defined construction sequencing plan, demonstrating a strong understanding of IRWD's operational constraints and need to minimize outages. Jacobs demonstrated a thorough understanding of the scope of work, supported by an appropriate list of drawings and specifications and a reasonable level of effort for each task. The consultant selection matrix is attached as Exhibit "A", and Jacobs' scope of work and fee proposal are attached as Exhibit "B".

Staff recommends that the Board authorize the General Manager to execute a Professional Services Agreement with Jacobs in the amount of \$938,942 for engineering design services for the East Irvine Zone 3-4 Pump Station project.

FISCAL IMPACTS:

Project 12565 is currently in the FY 2025-26 Capital Budget. This project is funded 100% from the Domestic Water Replacement Fund. A budget increase is required to fund the design and construction phases as shown in the table below:

Project No.	Current Budget	Addition <Reduction>	Total Budget
12565	\$ 2,500,000	\$ 3,780,000	\$ 6,280,000

ENVIRONMENTAL COMPLIANCE:

This project is subject to the California Environmental Quality Act (CEQA). In conformance with the California Code of Regulations Title 14, Chapter 3, Section 15004, the appropriate environmental document will be prepared when "meaningful information" becomes available.

RECOMMENDATION:

That the Board authorize a budget increase in the amount of \$3,780,000, from \$2,500,000 to \$6,280,000, and authorize the General Manager to execute a Professional Services Agreement with Jacobs in the amount of \$938,942 for engineering design services for the East Irvine Zone 3-4 Pump Station Rehabilitation, Project 12565.

LIST OF EXHIBITS:

- Exhibit "A" – Consultant Selection Matrix
- Exhibit "B" – Scope of Work and Fee Proposal

Exhibit "A"

CONSULTANT SELECTION MATRIX

East Irvine Zone 3-4 PS Rehab										
Item	Description	Weights	Brown and Caldwell		HDR		Jacobs		WHB Engineers	
A	<b>TECHNICAL APPROACH</b>									
1	Project Understanding and Approach	25%	2		3		1		4	
2	Related Project Experience	20%	3		2		1		4	
3	Project Team and Staff Qualifications	20%	3		2		1		4	
4	Scope of Work	25%	3		2		1		3	
5	History of Performance	10%	2		1		3		4	
	<u>Weighted Score</u>		2.7		2.2		1.2		3.8	
	<b>Ranking of Consultants</b>		3		2		1		4	
B	<b>SCOPE OF WORK</b>									
TASK	DESCRIPTION		Task Hours	Fee	Task Hours	Fee	Task Hours	Fee	Task Hours	Fee
1	<b>Project Management</b>		617	<b>\$159,478</b>	422	<b>\$128,300</b>	333	<b>\$91,577</b>	356	<b>\$95,506</b>
2	<b>Preliminary Design</b>		1,318	<b>\$312,244</b>	800	<b>\$239,600</b>	1,554	<b>\$351,511</b>	1,113	<b>\$258,046</b>
3	<b>Final Design</b>		2,195	<b>\$496,930</b>	2,425	<b>\$551,700</b>	2,034	<b>\$424,719</b>	1,286	<b>\$292,926</b>
4	<b>Bid Support</b>		82	<b>\$18,395</b>	142	<b>\$38,100</b>	102	<b>\$28,762</b>	120	<b>\$27,824</b>
	<b>TOTAL ENGINEERING SERVICES FEE</b>		4,212	<b>\$987,047</b>	3,789	<b>\$957,700</b>	4,161	<b>\$938,942</b>	3,086	<b>\$744,284</b>
C	<b>OTHER</b>									
	<b>Technical Drawings</b>									
	Total Sheets		56	dwgs	65	dwgs	40	dwgs	46	dwgs
	<b>Personnel</b>									
	<b>Role</b>		<b>Years of Experience</b>		<b>Years of Experience</b>		<b>Years of Experience</b>		<b>Years of Experience</b>	
	Project Manager		Kirstin Byrne Kale	15	Todd Engstrand	31	Marielle Coquia	30	Luis Soto	18
	Design Manager/Project Engineer		Ryan Mangosong	8	Curtis Gauthier	12	Deanie Ding	26	Justin Todd	12
	Electrical		Sang V. Vo	19	Andrew Tee	11	Adam Nichols	22	Long Pham	35
	Civil/Mechanical		Thomas Mihara	10	John Koch	57	Qingshan Wang	37	Dennis Schieber	29
	Instrumentation/Controls		Melvin Ridley	30	Curtis Horn	25	Adam Nichols	22	-	-
	<b>Sub Consultants</b>									
	Condition Assessment		Corrosion Probe, Inc.		-	-	-	-	On-Site Technical Services, Inc.	
	Hydraulic Analysis		-	-	-	-	-	-	Flow Science Incorporated	
	Surge Analysis		-	-	Scott Foster Engineering, Inc.		-	-	Mission Consulting Services	
	Survey		-	-	-	-	-	-	Coast Surveying, Inc.	
	<b>Insurance</b>									
	General Liability		Yes		Yes		Yes		Yes	
	Automobile		Yes		Yes		Yes		Yes	
	Workers' Compensation		Yes		Yes		Yes		Yes	

Note: This page is intentionally left blank.

PROPOSAL FOR

# Engineering Design Services for the East Irvine Zone 3 to 4 Pump Station Rehabilitation Project

SUBMITTED TO

Irvine Ranch Water District  
MARCH 31, 2026

March 31, 2026

Brian Waite, P.E.  
Engineering Manager – Treatment & Conveyance  
Irvine Ranch Water District  
15600 Sand Canyon Avenue  
Irvine, CA 92618

## **Subject: Proposal for Engineering Design Services for the East Irvine Zone 3 to 4 Pump Station Rehabilitation Project (PR 12565)**

Dear Mr. Waite:

Jacobs is pleased to submit this proposal to support Irvine Ranch Water District with engineering design services for the East Irvine Zone 3 to 4 Pump Station Rehabilitation Project. We understand the critical importance of this facility in sustaining Zone 4 pressures, serving upper pressure zones, and maintaining system reliability, particularly given the maximum allowable outage of only one to two days and the absence of a full bypass. Our team is prepared with proven strategies, specialized expertise, and a risk-focused delivery approach that is fully aligned with the requirements outlined in the RFP.

### **A Technical and Operationally Focused Approach**

Our approach integrates hydraulic modeling, mechanical rehabilitation, electrical and controls modernization, structural upgrades, and construction phasing from project inception. We will evaluate and validate alternatives such as reservoir level management, temporary bypass pumping, phased pump removal, staged MCC/switchboard cutovers, and controlled tie-ins, ensuring IRWD's operational reliability remains protected throughout construction. These elements mirror the scope and deliverables identified for preliminary and final design, including development of P&IDs/single-lines, surge/transient analysis, temporary power/implementation planning (TM-5), and a Class 3 to Class 2 cost estimate progression through 60/90/100% design.

### **An Irvine-Based Team, Assembled for IRWD's Highest-Risk Systems**

Jacobs has assembled an experienced local team specifically structured to address the highest-risk elements of the East Irvine Zone 3 to 4 Pump Station Rehabilitation, including phased implementation, temporary power, hydraulic validation, and modernization of critical mechanical, electrical, and control systems within an active facility. Our team brings deep experience working in operating water systems with strict outage limitations, including direct experience supporting IRWD and Southern California agencies.

Key team members include **Marielle Coquia, PE (Project Manager)**; **Deanie Ding, PE (Design Manager)**; **Ruoren Yu, PE (Hydraulic Modeling Lead)**; **Qingshan Wang, PE (Mechanical Lead)**; **Adam Nichols, PE (Electrical and I&C Lead)**; **Gino Nguyen, PE (Civil Lead)**; **Max Meng, PE (Structural Lead)**; **Kurt Lind (Condition Assessment Lead)**; and **Mike Hwang, PE (Quality Manager)**. Collectively, this team provides comprehensive expertise in pump station rehabilitation, surge and hydraulic modeling, switchboard and MCC replacement, PLC/SCADA modernization, canopy and foundation design, access and security improvements, and independent QA/QC aligned with IRWD standards.



### *Local Team!*

**The majority of this team is based in Jacobs' Irvine office, just a few miles from IRWD headquarters and the project site.**

This proximity provides immediate access to project leadership and discipline leads, enabling rapid response, frequent in-person coordination, and real-time resolution of design and field issues. During both design and construction, this local presence allows our team to work closely with IRWD staff and Operations to support phased implementation, temporary system coordination, and continuous facility operation.

By combining a highly experienced, pump-station-focused team with a strong local presence, Jacobs offers IRWD a delivery approach that reduces risk, improves coordination, and supports efficient, reliable implementation of this critical facility upgrade.

## Outage Mitigation Plans

Jacobs' outage mitigation strategy is built around IRWD's strict requirement that the East Irvine Zone 3 to 4 Pump Station cannot be offline for more than one to two days for any major tie-in and may not be taken fully out of service at any time except under controlled, pre-planned conditions. Our approach is driven by engineering-led phasing rather than contractor-led sequencing, ensuring every outage is predictable, brief, and operationally safe.

## Risk Management

Jacobs will implement a structured risk management program tailored to IRWD's outage, safety, and schedule constraints. We will maintain a live risk register with defined mitigation strategies, addressing key risks such as outage exceedance, long-lead procurement, arc flash and safety, constructability conflicts, and cost and schedule variance. Mitigation measures include tie-in matrices, rollback plans, temporary MCC and PLC cutovers, early vendor engagement, and multi-tier QA/QC reviews conducted for each milestone deliverable. Stage-gate risk workshops at PDR, 60%, and 90% will ensure risks are continuously evaluated and controlled.

## Cost Control

Jacobs will apply a disciplined cost management framework to maintain alignment with IRWD's budget. We will prepare Class 3 and Class 2 cost estimate at each major milestone, supported by cost variance tracking and early identification of cost drivers. By integrating hydraulic modeling, constructability review, and outage planning, we will refine design decisions to reduce uncertainty, minimize change orders, and provide cost transparency throughout the project lifecycle.

## Commitment to IRWD

Jacobs is committed to delivering a technically robust, constructible, and operationally reliable design that supports long-term asset performance. Our focus on phasing, surge mitigation, temporary systems, cost control, and outage management will reduce risk, protect service continuity, and ensure successful implementation.

We appreciate the opportunity to support IRWD and look forward to working closely with your Engineering and Operations teams. If you have any questions or need additional information, please contact Marielle Coquia, PE at 949.224.7626 or marielle.coquia@jacobs.com.

Sincerely,



**Marielle Coquia, PE**  
Project Manager  
marielle.coquia@jacobs.com  
949.224.7626

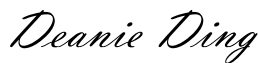

**Deanie Ding, PE**  
Design Manager  
deanie.ding@jacobs.com  
949.224.7805



**Rich Nagel, PE**  
Principal-in-Charge  
rich.nagel@jacobs.com  
213.500.2333

# Table of Contents

## CONTENTS

	PG #
1. Scope	1
2. Understanding and Approach	6
3. Staff Team Qualifications	10
4. Related Project Experience	12

## APPENDICES

A. Resumes
B. Drawings List
C. Schedule
D. Level of Effort
E. Contract
F. Statements for Joint Venture, Public Works Requirement & Conflict of Interest
G. Insurance
H. Team Location & Availability

## Jacobs at a Glance

### JACOBS LEADERSHIP POSITION

TOP 500 DESIGN FIRMS 2025 ENGINEERING NEWS RECORD (ENR)



**3.5k**

PUMP STATIONS  
INCLUDING 200 IN  
THE PAST 5 YEARS

**#1** PURE  
DESIGNER

**500**

COLLECTION SYSTEMS DESIGNED/OPERATED  
IN NORTH AMERICA



**#2** DESIGN  
FIRM

**#2** WATER TREATMENT,  
DESAL PLANTS

**#3** WATER  
SUPPLY

# SCOPE

IRWD | East Irvine Zone 3 to 4 Pump Station Rehabilitation Project

Jacobs will provide engineering design services for rehabilitation of the East Irvine Zone 3 to 4 Pump Station, with a primary focus on modernization of mechanical, electrical, and control systems while maintaining operational continuity of this critical domestic water facility. The design will assume a maximum outage window of approximately one to two days for major tie-ins and will be structured to avoid full station bypass wherever feasible. The scope of work to be performed is described in the tasks below and is based on our approach described in Section 2.0 and prioritizes temporary power planning, phased implementation sequencing, and hydraulic validation to minimize risk and ensure reliable long-term operation.

## Task 1 – Project Management

Jacobs will provide comprehensive project management services throughout the design and bidding phases to adhere to the scope, schedule, budget, and quality objectives. Services will include development and maintenance of a detailed design schedule in Microsoft Project; preparation of monthly progress reports; coordination and facilitation of required meetings; and proactive communication with IRWD staff and Southern California Edison (SCE).

A structured QA/QC program will be implemented with independent technical reviews at each major milestone. Phasing and temporary power strategy will be treated as a central management element and tracked throughout design development to confirm outage windows and tie-ins are fully coordinated with IRWD operations.

### Deliverables

- **Project Management Plan** – Jacobs standard documentation of key elements for project management and execution, shared with IRWD for reference.
- **Monthly Status Reports** – Including descriptions of work progress relative to budget and schedule and invoices.
- **Updated Design Schedule (monthly)** – Delivered with monthly status reports, in Microsoft Project.
- **Meeting Agendas and Minutes** – Generally 2 days in advance for agendas, and within 3 days after meetings for meeting minutes.
- **QA/QC Documentation Logs** – In forms or checklists with names of independent reviewers and responding engineers.

## Task 2 – Preliminary Design (PDR – ~30%)

Jacobs will perform preliminary design services to evaluate existing conditions and define the technical basis for final design. The PDR phase will be driven by temporary power planning and construction sequencing constraints of the East Irvine Zone 3 to 4 Pump Station Rehabilitation Project.

## 2.1 Background Information Research and Review

Jacobs will initiate Task 2 by developing an information request matrix to guide collection of all relevant background data, including prior studies, related operational and vendor documents, design, construction, and as-built drawings.

A comprehensive review of the information and associated hydraulic model (in InfoWater) will provide the foundational context for identifying and understanding the approach for the condition assessment. During this effort, Jacobs will also identify data gaps significant to evaluations and document a plan to resolve them through focused follow-ups or reasonable assumptions for transparency. Jacobs will meet with IRWD to discuss missing information and identify if any site investigations or inspections to clarify or confirm data gaps.

To consolidate findings and requests, Jacobs will include their findings and summarize the available background information in the pertinent technical memorandums to be developed.

## 2.2 Coordination with Outside Agencies

At the time of the proposal, SCE is the only permitting agency identified to be engaged for the Project. Jacobs will start coordinating with SCE as soon as the Project scope is defined. Early engagement of the agency would ensure that their requirements are considered and incorporated into the design, to avoid delays in the permit acquisition process. Two virtual meetings are anticipated to walk through the Project and discuss any comments with SCE.

If required, other agencies related to reviewing architectural designs for the canopy, CCTV structure (if any), or perimeter fence will be contacted for project coordination.

## 2.3 Condition Assessment

Jacobs will perform a comprehensive mechanical condition assessment and develop the design basis for rehabilitation of the pump station's mechanical systems. To enhance the results of the condition assessment evaluation, Jacobs will review historical operations reports, such as findings from any operation rehabilitation activities and meet with the Operations and Maintenance (O&M) staff to better understand operational challenges and confirm any issues identified. The preliminary design will assume replacement of major mechanical equipment, subject to validation through condition assessment and hydraulic analysis. This includes evaluation and planned replacement of all vertical turbine pumps and motors, the surge tank (pending confirmation through transient analysis), the air compressor system, above-grade valves, and associated piping and appurtenances. The existing chemical feed system will be evaluated and incorporated into the design if deficiencies are identified during assessment.

The results of the Condition Assessment and associated costs using Class 5 Rough Order of Magnitude (ROM) for rehabilitation vs replacement will be presented in a technical memorandum.

### Deliverables:

- **Draft TM-1 Condition Assessment** – three (3) hard copies and one (1) electronic copy in PDF format
- **Final TM-1 Condition Assessment**– three (3) hard copies and one (1) electronic copy in PDF format

## 2.4 Hydraulic Evaluation

Hydraulic modeling will be provided to confirm pump sizing, which may result in adjustment from the existing 250 HP units, and to evaluate potential configuration alternatives such as 2+2 versus 3+1 duty/standby arrangements. A surge analysis and an optional intake hydraulic modeling (with computational fluid dynamics [CFD]) will also be performed to ensure system reliability for long-term operation. See additional discussion on the hydraulic evaluation and recommended CFD modeling effort in the Project Understanding and Approach.

## 2.5 Pump Selection

Based on the hydraulic modeling analysis, the replacement pump units will be selected and presented in the hydraulic analysis tech memo. Pumps will be multi-stage vertical turbine type, clean water services, suitable for canned installations in outdoor environments. The preferred pump specifications will also be discussed with IRWD to establish the basis of detailed design.

A technical memorandum will summarize the findings of the hydraulic evaluation and pump selection and include a cost estimate per American Association of Cost Engineers (AAACE) Class 5 (-50% to +100% accuracy).

### Deliverables:

- **Draft TM-2 Hydraulic Analysis and Pump Selection** – three (3) hard copies and one (1) electronic copy in PDF format
- **Final TM-2 Hydraulic Analysis and Pump Selection** – three (3) hard copies and one (1) electronic copy in PDF format

## 2.6 Electrical and Controls Design Criteria

### 2.6.1 Project Codes, Standards, and SCE Requirements

Jacobs will evaluate relevant NEC and NFPA code compliance, arc flash hazard analysis and mitigation strategy, and protective relaying coordination. The findings, with the requirements through SCE coordination will be documented in a technical memorandum.

### 2.6.2 Electrical and Controls Design Criteria

Jacobs will develop the electrical, instrumentation and controls (I&C) design basis assuming full replacement of major electrical distribution and control components. This includes replacement of the main switchboard, motor starters (per IRWD standards), motor control centers, breakers, PLC cabinet and associated control panels, UPS battery system, the 12-inch magnetic flow meter located in the PRV vault, site lighting, and associated enclosures. At the time of this Proposal, we assume the replacement of conductors associated with the replaced equipment but existing buried conduits to be reused. If existing conduits are determined insufficient during the preliminary evaluation, Jacobs will coordinate with IRWD for incorporating it into the design scope for providing a complete functional facility. The design will maintain the existing 1600A service footprint unless otherwise directed, however, the demand load is much lower than the service size and it may be a consideration during preliminary design to reduce service size to save costs. The existing solar PV interface (301A capacity) will be confirmed but is not assumed to be in replacement scope unless officially directed by IRWD. Jacobs will also evaluate relocation of the reservoir level transmitter from the existing 35-foot vault location to improve safety and maintainability.

### 2.6.3 Implementation & Phasing Strategy

Jacobs will treat construction phasing and outage mitigation as the primary technical driver of design development. Given the pump station's critical role in maintaining Zone 4 system pressure and the constraint that the facility cannot be offline for a sustained period longer than approximately two days,

the design will be structured around controlled, limited-duration tie-ins. Detailed construction sequencing scenarios will be developed during preliminary design to evaluate pump removal strategies, staged equipment replacement, electrical gear cutovers within the existing footprint, and reservoir level management during implementation. Jacobs will develop a temporary power distribution strategy that allows electrical modernization to occur without extended service interruption. This will include evaluation of load transfer scenarios, temporary feeder routing, staged switchboard replacement, and sequencing of PLC migration by leveraging IRWD's temporary PLC equipment to minimize risk of control system downtime. Tie-in matrices and shutdown planning tables will be prepared to define allowable outage windows, required pre-construction preparation, and rollback contingencies. Phasing decisions will be integrated with proposed mechanical system modifications to ensure that system reliability is maintained throughout construction.

This structured approach ensures that outage exposure is minimized, contractor sequencing is clearly defined in the Contract Documents (i.e., Project Manual), and operational risks are identified and mitigated early in the design process. Up to 3 alternatives will be evaluated for various constraints and will include associated costs (AACE Class 5, -50% to +100% accuracy).

Electrical Controls and Design Criteria will be documented in three technical memorandums. The technical memorandums will be submitted three (3) hard copies and one (1) electronic copy in PDF format

#### Deliverables:

- **Draft TM-3 Relevant Project Codes, Standards and SCE Requirements** - three (3) hard copies and one (1) electronic copy in PDF format
- **Draft TM-4 Replacement Work: Design Criteria, Preliminary Sizing, and Layout** - three (3) hard copies and one (1) electronic copy in PDF format
- **Draft TM-5 Implementation Plan**- three (3) hard copies and one (1) electronic copy in PDF format
- **Final TM-3 Relevant Project Codes, Standards and SCE Requirements** - three (3) hard copies and one (1) electronic copy in PDF format
- **Final TM-4 Replacement Work: Design Criteria, Preliminary Sizing, and Layout** - three (3) hard copies and one (1) electronic copy in PDF format
- **Final TM-5 Implementation Plan**- three (3) hard copies and one (1) electronic copy in PDF format

## 2.7 Structural/Architectural Design Criteria

Jacobs will evaluate structural and architectural modifications required to support mechanical and electrical upgrades. Scope will include design of modifications to access hatches at the PRV vault, effluent flowmeter vault, and reservoir vault to improve maintenance access and safety. A new canopy structure will be designed to protect upgraded equipment from weather exposure. Equipment foundation modifications and structural supports required for new canopy, new mechanical or electrical installations will be evaluated and incorporated into the design. No comprehensive building structural evaluation is included unless directed by IRWD. Localized site grading may be proposed to direct stormwater runoff away from equipment. Jacobs will coordinate with IRWD Standards and any City of Irvine architectural requirements. Structural and architectural designs will be based on the appropriate layout or configurations to protect the equipment, design calculations, meeting code and city ordinance requirements. The design of this structure will be included in the Design Drawings included in the PDR.

## 2.8 Site Security Improvements

Jacobs will incorporate site security improvements consistent with the RFP requirements. Services will include development of CCTV conduit routing and coordination to support installation of new cameras at designated gate locations, and evaluation of upgrades to the existing perimeter chain-link fence to enhance security. Coordination with IRWD will clarify whether security equipment procurement will be included under this contract or provided separately, ensuring appropriate delineation of responsibilities within the design documents. Design of Site Security Improvements will be included in the Design Drawings included in the PDR.

## 2.9 Construction Schedule

Jacobs understands the complexity of implementing the upgrades and improvements while minimizing the down time of the pumping facility. A preliminary construction schedule will be developed based on output of the implementation and phasing strategy effort, under Item 2.6. Further discussion will also be made with IRWD to identify other constraints for scheduling the work. The Construction Schedule will be developed using Microsoft Project and include all construction activities related to the work, sequencing and phasing of work restrictions, submittal reviews, equipment fabrication lead times, permitting, inspections, and testing. Interim and major milestones will also be identified.

## 2.10 Opinion of Probable Construction Cost (OPCC)

AACE Class 3 (-20% to +30% accuracy) Opinion of Probable Construction Cost (OPCC) will be provided based on the Project scope and requirements defined in the preliminary design. The detailed cost breakdown will include facility direct costs, taxes, mobilization/demobilization, general conditions, contractor mark-ups, bonds and insurance, permitting, services during construction, and contingencies.

## 2.11 Preliminary Design Report

The Preliminary Design Report (PDR) will document the analyses, findings, and recommendations in the preliminary design (30%) phase. All technical memorandums, presentations, vendor information, and critical correspondence will be attached to the PDR. The PDR will also include a preliminary construction schedule, drawings and specifications lists anticipated for the final design.

### Deliverables

- **Draft and Final PDR** - three (3) hard copies and one (1) electronic copy in PDF format for each draft and final submittal
- PDR Appendices
- Technical Memorandums (TM-1 through TM-5)
- **Preliminary drawings including:** Mechanical Plan and Sections for Pump Replacement, Canopy Structure Plan and Sections, Vault Hatch Replacement Plan, Switchgear and MCC Elevations, Temporary Electrical System Plan, Reservoir Level Transmitter Relocation Plan, Single-Line Diagrams, and P&IDs
- List of the Technical Specification Sections (IRWD Standard Specifications)
- Preliminary Construction Schedule (Microsoft Project)
- Breakdown AACE Class 3 OPCC

## Task 3 – Final Design

Jacobs will prepare complete biddable and constructible Contract Documents in accordance with IRWD standards and requirements. The design will advance the phasing and temporary power plan developed during PDR and fully detail tie-in sequencing and outage windows. Jacobs will prepare the Project Manual consistent with IRWD standards and include the Final Service Plan. IRWD front-end documents, General Technical Specifications, and project-specific technical specifications as required for bidding and construction will be included in the Final Design packages.

Mechanical final design will include detailed pump selection,

pump station plans and sections, surge mitigation design, and associated piping and valve layout.

Electrical and I&C design will include detailed switchgear layouts, motor control center configurations, protective relaying coordination studies, arc flash mitigation measures, and PLC migration architecture. Final design will also include P&IDs, single-line diagrams, control equipment lists, I/O schedules, control narratives, loop descriptions, and documentation of SCADA integration consistent with IRWD automation standards. The Final SCE Service Plan will be obtained and incorporated into the design and included as an appendix of the Project Manual.

Civil and structural drawings will detail vault modifications, canopy structure, equipment foundations, site restoration, perimeter fencing, and coordination with underground utilities to support constructability and code compliance.

Updated AACE Class 2 (-15% to +20% accuracy) OPCCs and cost variance reports will be prepared at the 60%, 90%, and 100% design stages. During final design, the phasing and temporary power strategy developed in preliminary design will be advanced into fully detailed implementation documents. Construction sequencing diagrams, shutdown matrices, temporary system layouts, and cutover narratives will be incorporated into the Contract Documents to provide contractors with a clear roadmap for maintaining operations. Electrical cutovers, PLC migration, and mechanical tie-ins will be sequenced to limit any individual outage to the defined allowable window and to prevent cascading impacts to the distribution system. By embedding outage control measures directly into the design documents, Jacobs will reduce contractor ambiguity, minimize change order risk, and protect IRWD from extended service disruptions during implementation.

### Deliverables

- 60% Design Package (Drawings, Project Manual, Draft AACE Class 2 OPCC)
- 90% Design Package (Updated Drawings, Updated Draft OPCC, Variance Report)
- 100% Design Package (Biddable Contract Documents)
- Final Signed and Stamped Contract Documents
- AutoCAD Drawing Files
- Updated Construction Schedule
- Final AACE Class 2 OPCC (-15% to +20% accuracy) and Cost Variance Reports

## Task 4 – Bid Support

Jacobs will support IRWD during the bidding phase by responding to bidder questions, preparing up to three addenda, participating in the pre-bid meeting, and preparing conformed Contract Documents. If required, Jacobs will assist with post-bid evaluation in the event bids exceed the Engineer's estimate threshold.

### Deliverables

- Addenda (up to three)
- Responses to Bidder Questions
- Pre-Bid Meeting Materials
- Conformed Contract Documents
- Post-Bid Evaluation Memorandum (if required)

### Assumptions

- Maximum outage window limited to approximately 2 days per major tie-in.
- Major mechanical equipment replacement assumed unless condition assessment determines otherwise.
- No modifications to existing pump station inlet header system under the slab.
- The existing hydraulic model in InfoWater is up-to-date and calibrated to represent existing distribution networks.
- Reuse of existing buried conduits at pump station pad.
- Pump motor starter replacement assumed constant speed control; no VFDs included unless directed.
- Canopy to include new lighting.
- No changes to existing solar PV system unless directed.
- No building structural modifications included beyond the addition of a new canopy and hatch improvements.
- Surge analysis performed at engineering modeling level; advanced CFD for transient modeling not included.
- Permit fees reimbursed per RFP allowance. IRWD will coordinate and provide topographic mapping services to support civil improvements related to canopy installation, perimeter fence installation, and concrete pads.
- Implementation and integration of security cameras not included.
- No changes to site grading or drainage system.
- Topographic map of current conditions will be provided in AutoCAD platform will be provided by IRWD. If additional or updated topographic data is required to complete designs, IRWD will coordinate and obtain current topographic mapping to provide to Jacobs.
- Deliverables will be submitted in the formats specified in the RFP.
- Per the RFP, the scope of services extends through bid services and does not include engineering services during the construction phase. Jacobs can offer services during construction (SDC) to IRWD, which would typically include submittal/shop drawing review, responses to requests for information (RFIs), preparation of design change notices (DCNs) and preparation of record drawings. If desired, Jacobs can provide a scope and fee for these services based on further discussions with IRWD, if appropriate at this stage in the project.

# PROJECT UNDERSTANDING AND APPROACH

IRWD | East Irvine Zone 3 to 4 Pump Station Rehabilitation Project

## Understanding of the Core Challenge

The East Irvine Zone 3 to 4 Pump Station (PS) is a critical domestic water pumping facility in IRWD's water system. The most significant operational constraint is the maximum allowable outage of approximately two days, with no readily available bypass. In addition, there is no true isolation currently in place for individual pump intakes. As a result, *this project requires an engineering-driven phasing approach rather than construction-driven sequencing.*

Jacobs recognizes that the East Irvine/Portola Springs Zone 4 system is pressurized by the East Irvine 4 and Portola Springs 4 Reservoirs, which are supplied by two Zone 3 to 4 pump stations: the East Irvine Zone 3 to 4 Pump Station and the Portola Springs Zone 3 to 4 Pump Station. The East Irvine Zone 4 system also directly supplies four upper zones, Portola Springs Zone 6, Foothill Ranch Zone 6, Lake Forest Zone 4, and Irvine Zone 4R1, through pump stations or control valves. When the East Irvine Zone 3 to 4 Pump Station is offline, such upper zones are supplied solely by the Portola Springs Pump Station. Refer to **Figure 2.1** for an overview of the existing hydraulic zone network associated with East Irvine Zone 4. To meet system demand and maintain redundancy, it is critical to either maintain operation of the East Irvine Pump Station or provide temporary pumping from the Zone 3 reservoirs to Zone 4.

Jacobs has identified two potential approaches that will be further evaluated and discussed with IRWD during preliminary design to determine the most practical and reliable solution.

**Reservoir Level Management:** The first approach involves constraining the reservoirs' high water elevation below the pump station site grade elevation (approximately 463 ft). This could be done by adjusting the high-level setpoint of the reservoir feed control valve, preferably with a buffering room. This approach will allow individual pumps to be removed and replaced without interfering with other units. A modeling analysis using the existing InfoWater model could be performed to evaluate the impact on East Irvine Zone 3 system with a lower reservoir level setpoint. The key advantage of this approach is cost savings associated with pumping bypass system. However, it would not allow for full isolation of the suction header or pump cans, in case rehabilitation or modifications are required.

**Temporary Pumping:** The second approach involves running temporary bypass pumps to draw water from the Zone 3 reservoirs and pump to Zone 4 distribution system. There are existing locations for potentially connecting temporary pump suction and discharge piping (near the pressure reducing valve vault), which would be discussed with IRWD for feasibility and constraints. This approach would maintain reservoir levels (i.e., less impact on Zone 3 operation) and could mitigate the risk of spills through the open pump cans during construction. This will also allow for rehabilitation of pump cans if determined necessary through the condition assessment and the (optional) CFD modeling analysis. To mitigate the cost impact, the temporary pumping occurrence and duration will be evaluated throughout the design to avoid unnecessary spending.

**Figure 2.1 - Partial IRWD Hydraulic Schematic**

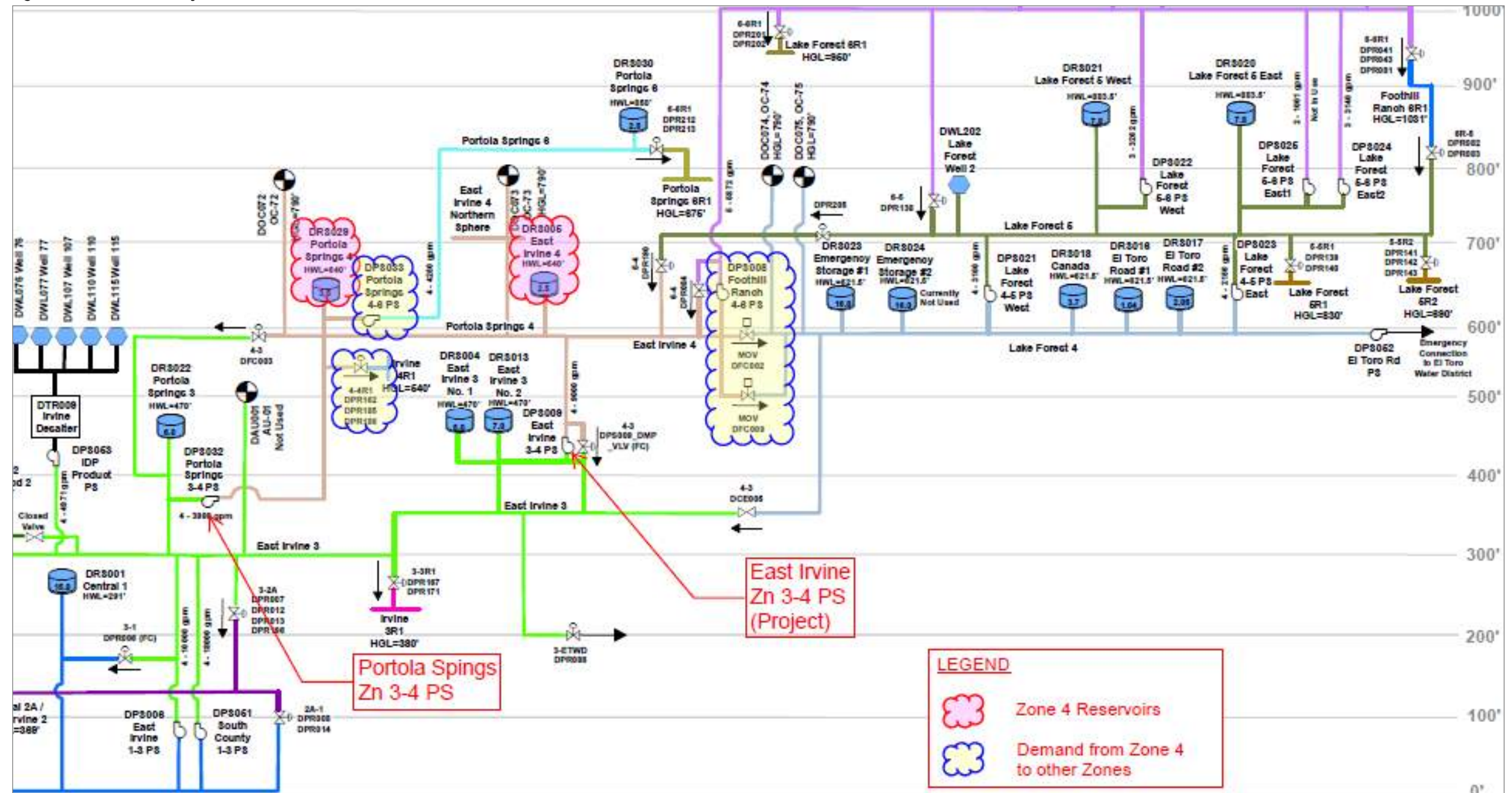

Jacobs also recognizes that existing pump conditions vary. One unit was under rehabilitation during the pre-proposal meeting, and another appeared to have been recently rehabilitated. The causes of past operational issues and premature pump failures will be investigated during preliminary design. Based on experience at similar facilities, *potential causes include*:

- **Pump intake issues**, such as insufficient net positive suction head (NPSH) or turbulent flow (vortices), leading cavitation and excess vibrations.
- **Inappropriate impeller design or changing hydraulic conditions in the system**, shifting the actual operating point(s) outside the preferred operating range.
- **Frequent pump cycling**, which exceeds electric motor’s limit.

During the condition assessment and hydraulic modeling stage, Jacobs will have one focus on a comprehensive analysis of the PS’s hydraulic conditions, as described in the following section.

## Delivery Strategy

Jacobs will structure the design as follows:

### Hydraulics First

The hydraulic analysis task will consist of three primary subtasks.

- **Distribution System Modeling Analysis:** First, distribution system modeling analysis will be performed to determine the preferred pump performance and duty/standby configuration. *The station currently operates as 2 duty and 2 standby pumps and could transition to 3 duty and 1 standby pump (configuration as intended in the original design), if needed.*

The results of this analysis will guide decisions related to pump rehabilitation or replacement, as well as define electrical and mechanical design criteria.

- **Evaluate Existing Open-Bottom Pump Can:** Second, we will evaluate the existing open-bottom pump can intake conditions based on Hydraulic Institute (HI) 9.8 design criteria. Optionally, a CFD model as illustrated in **Figure 2.2** will be built to analyze the existing pump intakes, aiming to identify any deficiencies contributing to operational issues and potential mitigation measures. We recommend CFD modeling to be included in the preliminary design because of 1) the criticality of the facility, 2) repeating premature pump failures, and 3) the relatively high flow capacity. Note that HI 9.8 requires a physical hydraulic model study to be conducted for open bottom canned pump with 5,000 gpm or higher flowrate per pump. For the East Irvine Zone 3 to 4 PS with 3,000 gpm unit capacity, we consider CFD as an informative tool for evaluating existing intake design and validating potential improvements. If deemed necessary by the study, we will make recommendations to improve pump operation for incorporating in the design.
- **Surge/Transient Analysis:** Third, although IRWD staff indicated hydraulic surges historically were not observed, a surge/transient analysis will be performed on the pump station discharge line to validate the surge protection system, such as the hydropneumatic tank volume and settings, to ensure long-term reliability.

The results of this hydraulic analysis will establish the basis for process-mechanical design and determine major electrical load requirements.

Figure 2.2 Pump Station CFD Model and Results

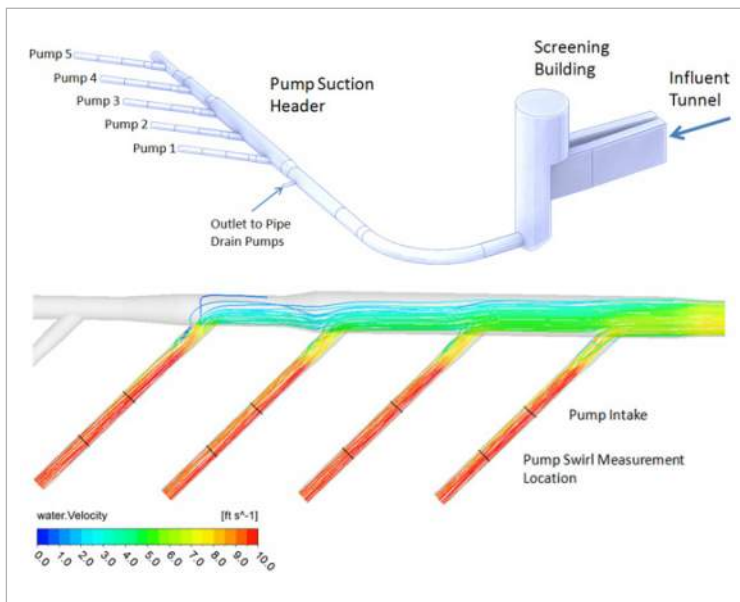

### Phasing-Driven Design

Jacobs will develop implementation alternatives during the Preliminary Design Report (PDR) phase.

#### Pump station rehabilitation sequencing strategy:

As described previously, we understand the criticality of maintaining the PS operation. Jacobs will develop alternatives to phasing the construction activities to be discussed with IRWD team and incorporated into the PDR. The pertinent requirements could then be included in the Project Manual as special provisions for the Project. The sequencing strategy may include the following considerations:

- As it is assumed that the power and control components would be replaced in place, temporary power distribution and controls are expected to be necessary during the shutdown period of these electrical components.

- Isolation of the vertical turbine pumps, piping sections, and surge tank will be evaluated during the condition assessment phase. Any special provisions or actions should be identified for isolating the components during construction.
- Construction of the new canopy structure is not anticipated to interfere with the PS operation but will be validated during preliminary design.

## Technical Execution

### Condition Assessment (TM-1)

Based on our understanding of the RFP scope, we plan to include the following items listed in **Table 2.1** in the proposed condition assessment. We will also include an allowance for additional investigation to address any unforeseen conditions.

**Table 2.1 Condition Assessment Impacts**

Description	Category	Potential Impacts
Surge protection system components	Mechanical & Instrumentation	Minimal (discharge system may lose surge protection temporarily)
Pump cans	Mechanical	Temporary shutdown of PS and drain of suction header
Reservoir flow control valve vault	Safety	None/minimal
Access hatches on pressure reducing valve vault and effluent meter vault	Safety	None/minimal
Chemical storage and feed systems	Mechanical & Safety	None/minimal

### Hydraulic Modeling (TM-2)

Hydraulic modeling will be performed as described above to validate system performance, confirm pump sizing, and establish the technical basis for design.

### Electrical & Controls Modernization (TM-3, TM-4, and TM-5)

In **TM-3, Relevant Project Codes, Standards and SCE Requirement**, Jacobs will evaluate code compliance with the existing facilities and the electrical upgrades planned for these facilities to ensure a safe and reliable system for operation and maintenance personnel. Additionally, Jacobs will ensure the preliminary design is in compliance with IRWD project and construction manuals. Based on the service size, the coordination with SCE is expected to be at a minimum since it is well above the expected demand load. Jacobs will coordinate with SCE by filling out their new online application process for replacement of electrical equipment and confirm temporary power can be accommodated.

For **TM-4, Replacement Work**, which requires design criteria, preliminary sizing and layout, Jacobs will evaluate the new layout by maintaining a compact footprint for the new electrical equipment and canopy. The approach would be to reuse existing conduit penetrations in the pump station slab to minimize installation time. Jacobs will evaluate providing a separate PLC enclosure versus including the control system equipment as part of the MCC lineup considering lead time, footprint, and ease of installation. Based on the results of the hydraulic model and the constructability of the process mechanical upgrades within the given shutdown period, the preliminary design for the size and number of duty pumps will be determined. Based on discussion with IRWD, Jacobs will determine the service size needed to handle current and future demand load at the site

### QA/QC Management of All Work Products

Mike will oversee the crucial aspect of quality assurance and quality control reviews for this project. One of his primary responsibilities is to develop a comprehensive quality management plan (QMP) That meticulously outlines the roles, responsibilities, and processes involved in QA/QC. This document will serve as a blueprint for maintaining the highest standards throughout the project. The Plan, Do, Check, Deliver graphic illustrates the quality review cycle for our project deliverables.

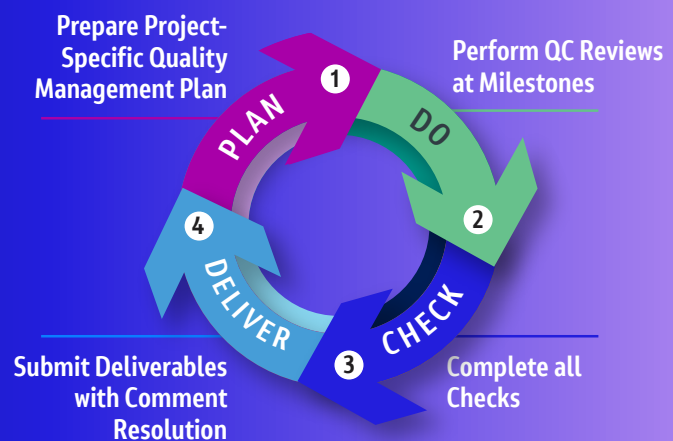

to efficiently size the electrical equipment as well as any other accommodation such as standby generator connection as well as the existing solar and potentially a second solar tap in the service gutter of the switchboard. For additional safety, Jacobs will investigate arc flash mitigation strategies for new electrical equipment such as the use of solid state trip units including maintenance mode, zone selective interlocking, current-limiting fuses, and arc-resistant equipment. Regarding motor control and the control system, Jacobs will work with IRWD to ensure new standards are met. Jacobs will work with IRWD to develop pre-procurement specifications for long-lead electrical equipment during preliminary design including potentially the temp MCC.

**TM-5, Implementation Plan**, is an important element of the design. Given the field conditions, there are not many options for keeping the station online. Below is **Table 2.2** with a list of options available. Due to the age of the equipment, Option 1 is not recommended to reuse the existing electrical equipment for temporary power. Similarly, Option 2 is not recommended since it doesn't meet project expectations.

**Table 2.2 – Temporary Power Options**

Opt.	Description	Pros	Cons
1	Reuse Existing MCC	<ul style="list-style-type: none"> <li>Less costly</li> <li>No change in components or number of pumps available</li> </ul>	<ul style="list-style-type: none"> <li>Aged equipment</li> <li>Potential Equipment failure during relocation causing expensive emergency operation</li> </ul>
2	Extended Shutdown	<ul style="list-style-type: none"> <li>Simpler construction</li> <li>No temporary power required</li> </ul>	<ul style="list-style-type: none"> <li>Does not meet project expectations</li> <li>More costly for keeping water distribution operational</li> </ul>
3	Rent Temp MCC	<ul style="list-style-type: none"> <li>Faster lead time</li> </ul>	<ul style="list-style-type: none"> <li>Dependent on construction schedule for rental costs</li> <li>Limited options</li> </ul>
4	Purchase Temp MCC	<ul style="list-style-type: none"> <li>Ability to customize project specific requirements</li> <li>Most flexibility for construction schedule</li> </ul>	<ul style="list-style-type: none"> <li>More expensive and longer lead time</li> <li>Will need to be stored after project and either used for spare parts or future projects if feasible</li> </ul>

Option 3 or 4 for temporary power is shown in **Figure 2.3** for location of pad mounted temporary power equipment and above grade pump feeders. During preliminary design, more discussion with IRWD will be needed to determine temp MCC components, number of motor starters, and ability to run on standby power. The final approach will be defined in the Drawings and Specifications for temporary power and PLC requirements.

**Figure 2.3 - location of pad mounted temporary power equipment and above grade pump feeders**



## Final Design, Cost Control & Risk Management

Jacobs will maintain a disciplined approach to cost and risk management throughout design by preparing Class 3 and Class 2 Opinions of Probable Construction Cost, tracking cost variances between design milestones, identifying long-lead equipment risks early, and aligning design with IRWD standards and operational requirements. Construction sequencing and implementation strategies developed during preliminary design will be advanced into detailed Contract Documents, including shutdown plans, temporary system layouts, and electrical cutover strategies. By integrating the findings of TM-1 through TM-5 into the design process, Jacobs will deliver a coordinated, constructable solution that minimizes outage risk, reduces contractor ambiguity, and ensures reliable implementation.

# STAFF TEAM QUALIFICATIONS

IRWD | East Irvine Zone 3 to 4 Pump Station Rehabilitation Project

The majority of key and supporting team members are based in our Irvine office!

## Team Introduction

Jacobs has assembled a senior, pump-station-focused team specifically structured to mitigate risk, maintain operational continuity, and modernize this critical IRWD facility with minimal disruption. Our team is anchored by strong leadership and proven delivery experience in active water and wastewater environments where shutdowns must be tightly managed and upgrades must be sequenced with precision.

**Leadership That Drives Clarity, Discipline, and Operational Alignment.** Marielle Coquia, PE, Project Manager, and Deanie Ding, PE, Design Manager, lead a disciplined, milestone driven design effort that integrates hydraulic validation, mechanical replacement, electrical modernization, structural upgrades, and construction phasing from the outset. Their leadership ensures proactive coordination with IRWD Operations, early identification of shutdown constraints, clear definition of tie in requirements, and deliberate planning for temporary power and implementation sequencing.

**Technical Depth Aligned to IRWD's Highest-Risk Systems.** Each major technical risk area is addressed by an experienced discipline lead. Qingshan Wang, PE oversees pump, mechanical, and surge system rehabilitation; Ruoren Yu, PE validates hydraulic adequacy and transient performance under phased operations; and Adam Nichols, PE directs electrical distribution, MCC and switchgear replacement, PLC modernization, SCADA integration, and arc flash compliance. Gino Nguyen, PE, and Max Meng, PE, guide civil and structural modifications to ensure constructability, site coordination, and compliance with IRWD standards. Kurt Lind provides constructability review, shutdown planning to further reduce implementation risk. Supporting all technical elements is Mike Hwang, PE, Quality Assurance Manager, who ensures rigorous QA/QC and technical consistency across electrical, controls, protection, and SCADA deliverables.

**Phased Implementation Designed to Protect Continuous Service.** This integrated team brings demonstrated experience upgrading active water facilities under highly constrained operating conditions. By embedding phasing strategy, temporary systems planning, surge and hydraulic validation, constructability review, and independent quality control into every design milestone, Jacobs will deliver coordinated improvements that enhance reliability, reduce lifecycle risk, and position the East Irvine Zone 3 to 4 Pump Station for dependable service over the next 25 years.

The following section provides detailed team member bios and an experience matrix demonstrating alignment between team capabilities and the IRWD project scope. Full resumes are included in Appendix A – Resumes.



## Key Team Member Bio and Experience Matrix

Name, Project Role & Office Location	Key Team Member Bios	Relevant Project Experience	Relevant Professional Experience	Availability
<b>MARIELLE COQUIA, PE</b> Project Manager Irvine, CA	30+ years delivering pump station, groundwater, and treatment facility upgrades across Southern California. Experienced managing phased improvements in active facilities where maintaining operations is critical.	<ul style="list-style-type: none"> <li>• OCWD / City of Tustin – PFAS Treatment System, Pump Station Rehabilitation and Conveyance</li> <li>• SOCWA - J.B. Latham Advanced Wastewater Treatment Preliminary Design</li> <li>• EMWD - Perris Valley, Moreno Valley, and San Jacinto Valley Water Reclamation Facilities Sodium Hypochlorite Conversion</li> </ul>	<ul style="list-style-type: none"> <li>• Pump Station Infrastructure Delivery</li> <li>• Phased Construction in Operating Facilities</li> <li>• Multidisciplinary Design Coordination</li> <li>• Southern California Water Agency Delivery</li> </ul>	50%
<b>DEANIE DING, PE</b> Design Manager Irvine, CA	25+ years delivering multi-disciplinary water infrastructure upgrades including pump stations, treatment facilities, and conveyance systems. Experienced coordinating civil, mechanical, electrical, and operational requirements into practical design solutions.	<ul style="list-style-type: none"> <li>• OC San – Supplemental Engineering &amp; Support Staff Services Program</li> <li>• Cal Water – Infrastructure Program and Treatment Facility Upgrades</li> <li>• Port of Long Beach – Pump Station Upgrade Peer Review</li> </ul>	<ul style="list-style-type: none"> <li>• Multidisciplinary Design Integration</li> <li>• Constructability-Driven Design</li> <li>• Phased Design Development</li> <li>• Pump Station and Facility Coordination</li> </ul>	20%
<b>MIKE HWANG, PE</b> QA/QC Manager Irvine, CA	Experienced water infrastructure engineer providing independent technical review and QA/QC oversight. Ensures designs meet regulatory requirements, agency standards, and interdisciplinary coordination prior to milestone submissions.	<ul style="list-style-type: none"> <li>• IRWD Non-Potable Well PFAS Study</li> <li>• LASAN / LADWP – Donald C. Tillman Advanced Water Purification Facility</li> <li>• OCWD / City of Tustin – PFAS Treatment System, Pump Station Rehabilitation and Conveyance</li> <li>• OCWD – PFAS Treatment Testing and System Design Program</li> </ul>	<ul style="list-style-type: none"> <li>• Technical QA/QC</li> <li>• Design Validation and Risk Mitigation</li> <li>• Design Management</li> <li>• Hydraulic and System Performance Evaluation</li> </ul>	20%
<b>QINGSHAN WANG, PE</b> Mechanical Lead Irvine, CA	30+ years mechanical design experience including pump stations, equipment replacement, piping systems, and advanced treatment facilities. Experienced with vertical turbine pumps and surge protection systems.	<ul style="list-style-type: none"> <li>• LASAN / LADWP – Donald C. Tillman Advanced Water Purification Facility</li> <li>• Cal Water – Infrastructure Program and Treatment Facility Upgrades</li> <li>• MWD – CRA Pumping Plant Sump System Rehabilitation</li> </ul>	<ul style="list-style-type: none"> <li>• Vertical Turbine Pump Systems</li> <li>• Pump Station Equipment Replacement</li> <li>• Piping &amp; Surge Protection Design</li> <li>• Advanced Treatment Facility Mechanical Systems</li> </ul>	30%
<b>RUOREN YU, PE</b> Hydraulic Modeling Lead Los Angeles, CA	Specialist in pump system modeling and surge analysis for municipal water agencies. Experienced validating pump sizing and system performance during transient conditions.	<ul style="list-style-type: none"> <li>• IRWD – Multi-Zone Pump Station Hydraulic Modeling</li> <li>• IEUA – RP-1 Zone Pump Station Upgrades</li> <li>• Golden State Water – System Hydraulic and Water Quality Modeling</li> </ul>	<ul style="list-style-type: none"> <li>• Hydraulic Modeling for Pump Stations</li> <li>• Surge &amp; Transient Analysis</li> <li>• Pump Capacity Optimization</li> <li>• Pressure Zone System Analysis</li> </ul>	40%
<b>ADAM NICHOLS, PE</b> Electrical & I&C Lead Irvine, CA	20+ years designing electrical distribution and control systems for water facilities including switchgear replacement, PLC modernization, SCADA integration, and phased electrical cutovers.	<ul style="list-style-type: none"> <li>• OCWD / City of Tustin – PFAS Treatment System, Pump Station Rehabilitation and Conveyance</li> <li>• Cal Water – Infrastructure Program and Treatment Facility Upgrades</li> <li>• LASAN / LADWP – Donald C. Tillman Advanced Water Purification Facility</li> <li>• WRD - Goldsworthy Desalter Expansion</li> </ul>	<ul style="list-style-type: none"> <li>• Electrical Distribution Replacement</li> <li>• PLC / SCADA Modernization</li> <li>• Arc Flash &amp; Code Compliance</li> <li>• Phased Electrical Cutovers</li> </ul>	50%
<b>MAX MENG, PE</b> Structural Engineer Irvine, CA	Structural engineer experienced in equipment foundations, vault modifications, and structural retrofits supporting water and wastewater infrastructure upgrades.	<ul style="list-style-type: none"> <li>• Cal Water – Infrastructure Program and Treatment Facility Upgrades</li> <li>• WRD - Goldsworthy Desalter Expansion</li> <li>• LACSD - Sidestream Centrate Treatment Facility</li> </ul>	<ul style="list-style-type: none"> <li>• Equipment Foundations and Structural Retrofits</li> <li>• Seismic Compliance for Utility Facilities</li> <li>• Pump Station Structural Improvements</li> <li>• Integration with Mechanical and Electrical Systems</li> </ul>	50%
<b>GINO NGUYEN, PE</b> Civil Engineer Irvine, CA	27 years of civil design for water infrastructure including grading, drainage, yard piping, and underground utility coordination in active facilities.	<ul style="list-style-type: none"> <li>• LASAN / LADWP – Donald C. Tillman Advanced Water Purification Facility</li> <li>• El Toro Water District – Water Reclamation Plant Expansion</li> <li>• City of Oxnard – Advanced Water Purification Facility</li> </ul>	<ul style="list-style-type: none"> <li>• Site Civil Design for Pump Stations</li> <li>• Yard Piping and Utility Coordination</li> <li>• Stormwater and Drainage Design</li> <li>• Constructability in Active Facilities</li> </ul>	75%
<b>KURT LIND</b> Condition Assessment Lead Turlock, CA	30+ years operations and asset management experience performing facility condition assessments and supporting infrastructure upgrades in operating utility facilities.	<ul style="list-style-type: none"> <li>• WRD - Goldsworthy Desalter Expansion</li> <li>• City of Gresham - Wastewater Treatment Plant Equipment Condition Assessment</li> <li>• City of Bellingham - Post Point Wastewater Treatment Plant Headworks Condition Assessment and Bypass Project</li> </ul>	<ul style="list-style-type: none"> <li>• Facility Condition Assessment</li> <li>• CCTV and Security Systems Integration</li> <li>• Operational Risk Identification</li> <li>• Asset Evaluation and Upgrade Planning</li> </ul>	25%
<b>QUENTIN CLARK, PE</b> Constructability San Diego, CA	28+ years of experience delivering water infrastructure projects from design through construction, with a focus on constructability, sequencing, and maintaining operations in active facilities. Provides field-driven insight to align design with construction methods, reduce risk, and support efficient project delivery.	<ul style="list-style-type: none"> <li>• SDCWA - Mission Trails Flow Regulatory Structure II</li> <li>• City of Fresno - Recharge Fresno Capital Improvement Program</li> <li>• Chicago Dept. of Water Management - CIP Delivery Program</li> </ul>	<ul style="list-style-type: none"> <li>• Construction Sequencing and Phasing Strategies</li> <li>• Maintain Operations During Construction</li> <li>• Constructability Review and Field Coordination</li> <li>• Contractor Coordination and Risk Mitigation</li> </ul>	20%
<b>KEVIN BUTCHER</b> Cost Estimator Redding, CA	With 27 years of experience estimating complex water, wastewater, and pumping infrastructure, Kevin provides rigorous Class 1–4 cost leadership across planning, design, and construction. He delivers accurate, defensible estimates that align scope, sequencing, and operational constraints to support reliable capital decision-making.	<ul style="list-style-type: none"> <li>• City of San Diego - Metropolitan Biosolids Center Improvements</li> <li>• EMWD - Temecula Valley Regional Water Reclamation Facility Expansion</li> <li>• Lake Arrowhead CSD - Water Reclamation &amp; Integrated Water Resources Plan</li> </ul>	<ul style="list-style-type: none"> <li>• Specialized in Class 1–4 estimates</li> <li>• Lead estimator for major pump station, hydraulic structure, and treatment plant projects</li> <li>• Experienced in cost control during design and construction</li> </ul>	15%
<b>RICH NAGEL, PE</b> Principal-in-Charge Los Angeles, CA	35+ years leading Southern California water infrastructure programs including treatment and conveyance facilities. Provides executive oversight and ensures alignment with agency operational priorities.	<ul style="list-style-type: none"> <li>• WBMWD – ECLWRF Phase V Design-Build Expansion</li> <li>• WRD – Regional Brackish Water Reclamation Program</li> <li>• LVMWD – Pure Water Project</li> </ul>	<ul style="list-style-type: none"> <li>• Executive Oversight of Major Water Programs</li> <li>• Southern California Agency Leadership</li> <li>• Risk &amp; Program Governance</li> </ul>	25%

# RELATED PROJECT EXPERIENCE

IRWD | East Irvine Zone 3 to 4 Pump Station Rehabilitation Project

Local Projects by a Local Team!

## Local Team. Local Knowledge. Reliable Delivery.















































































































Jacobs brings directly relevant experience delivering pump station rehabilitation, electrical and control system modernization, hydraulic analysis, and phased infrastructure upgrades within active water and wastewater facilities by team members. The projects presented in this section demonstrate our ability to replace and integrate mechanical and electrical systems including pumps, motors, piping, valves, switchgear, motor control centers (MCCs), and PLC/SCADA platforms while maintaining continuous operation of critical infrastructure.

Our experience spans a wide range of pumping facilities, from large-capacity raw and wastewater pump stations to booster stations and integrated treatment facility pumping systems. We have successfully performed pump selection and replacement, hydraulic modeling and surge analysis, and system optimization to ensure reliable long-term performance. In parallel, we deliver comprehensive electrical distribution and instrumentation and controls upgrades, including switchboard and MCC replacement, protection systems, and full PLC/SCADA modernization.

A key differentiator of Jacobs is our ability to execute these improvements within operating facilities where downtime must be minimized. Our teams develop phased construction strategies, temporary power solutions, and detailed cutover sequencing to maintain service continuity. We integrate constructability reviews, multidisciplinary coordination, and rigorous QA/QC processes throughout design and construction to reduce risk, protect schedule, and ensure successful implementation.

The projects on the following pages demonstrate Jacobs' ability to deliver complex, multidisciplinary upgrades that align directly with IRWD's project requirements, including pump station rehabilitation, electrical modernization, hydraulic and surge evaluation, and phased implementation in active facilities. *Collectively, these projects demonstrate Jacobs' ability to deliver reliable, constructible, and operationally resilient solutions for critical water infrastructure systems.*

 Main Attribute  Secondary Attribute

Project	Pump Station Rehabilitation	Pump Selection & Replacement	Hydraulic Modeling & Surge Analysis	Large Diameter Pipelines	Electrical Distribution Modernization	PLC & SCADA Modernization	Phased Implementation & Maintain Operations	Temporary Power & Cutover Sequencing	Condition Assessment & Facility Integration	Constructability Review	QA/QC & Multidisciplinary Coordination
<b>EchoWater Pump Station (PEPS)</b> Sacramento Regional County Sanitation District Sacramento, CA											
<b>Low Lake Level Pumping Station (L3PS)</b> Southern Nevada Water Authority (SNWA), Lake Mead, NV											
<b>San Diego International Airport Development Plan Airside Improvements</b> San Diego County Regional Airport Authority San Diego, CA											
<b>Pure Water San Diego (Morena Pump Station),</b> City of San Diego San Diego, CA											
<b>Sites Reservoir – HC Conveyance Facilities</b> Sites Project Authority Glenn County/Colusa County/Yolo County, CA											
<b>Delta Conveyance Project</b> Delta Conveyance Design and Construction Authority Sacramento, CA											
<b>Donald C. Tillman Advanced Water Purification Facility</b> City of Los Angeles (LASAN / LADWP) Los Angeles, CA											
<b>PFAS Treatment System &amp; Conveyance</b> Orange County Water District / City of Tustin Tustin, CA											
<b>WRD Goldsworthy Desalter Expansion &amp; Brackish Wells Water Replenishment District of Southern California</b> Torrance, CA											
<b>Treatment &amp; Pumping Plants Facility Security Enhancement</b> Metropolitan Water District of Southern California Southern, CA											

## California Water Service Pump Station and Electrical System Upgrade Program

STATEWIDE, CALIFORNIA | 2020-2027 | PROGRAM VALUE: OVER \$1 BILLION

Jacobs provides long-term engineering, design, and construction support for California Water Service's system-wide capital improvement program. This includes **over sixty task orders across 24 districts, each involving some combination of pump station rehabilitation, electrical distribution replacement, pipeline integration, and system modernization.**

### CLIENT REFERENCE

**Karina Winje, PE – Construction Program Quality Manager, California Water Service**  
1955 S. Atlanta Blvd., Monterey Park, CA 91754 | kwinje@calwater.com | 310-257-1486 (office) | 424-488-4984 (cell)



### Sacramento Regional County Sanitation District Primary Effluent Pump Station

*Project included civil and mechanical design of large pumping stations and preliminary engineering and the preparation of plans, specifications, and cost estimates. Jacobs utilized 3D modeling to provide the visualization of piping and other conflicts required for Jacobs and SRCSD to work together and develop solutions consisting of design concepts and details.*

### PUMP STATION & MECHANICAL SCOPE

Jacobs has executed upgrades involving:

- Replacement of **end-of-life pumps and motors**, including integration of new pump curves, suction/discharge modifications, and hydraulic performance balancing.
- Rebuilds of existing pump stations including **pump bowl replacements**, column pipe renewal, and vertical turbine pump installation.
- Piping reconfiguration to improve operational flexibility, reduce head losses, and streamline maintenance access.

#### Representative projects include:

- **PV15 Station Rebuild** – installation of new pumps and motors with integration into existing wet-well and suction/discharge header geometry.
- **Hermosa Redondo (HR027) Station Rebuild** – rehabilitation of pump station building, mechanical equipment, and chemical facility upgrades.

### ELECTRICAL DISTRIBUTION & CONTROLS SCOPE

Jacobs performs comprehensive electrical modernization efforts such as:

- Replacement of **switchboards, motor control centers, panelboards**, and standalone electrical service cabinets.
- Migration of legacy control systems to modern **programmable logic controller architectures**.
- **Supervisory control and data acquisition upgrades** across multiple water districts.
- Short circuit, arc-flash, and coordination updates to ensure compliance with modern standards.
- Electrical tie-ins and conduit/wiring renewal across multiple sites.

### PHASING, TEMPORARY POWER & CONSTRUCTION SEQUENCING

Because California Water Service systems must remain online, Jacobs develops:

- Detailed **temporary power plans** to maintain pump station operability during electrical upgrades.
- **Phased MCC/switchboard cutovers** for minimal outage durations.
- Sequencing plans for pump replacement to maintain pressure zone stability.

### PROJECT OUTCOMES

- Improved system reliability and modernization of aging stations.
- Minimized service disruptions through careful phasing.
- Accelerated delivery using standardized electrical and mechanical design approaches.
- Enhanced regulatory compliance related to safety, electrical, and sanitary requirements.

### KEY PERSONNEL

Deanie Ding, PE; Adam Nichols, PE; Michael Wang, PE; Max Meng, PE; Minette Lava, EIT

## Los Angeles Sanitation and Environment & Los Angeles Department of Water and Power Donald C. Tillman Advanced Water Purification Facility

CITY OF LOS ANGELES, CALIFORNIA | 2023 - 2028 | \$740 MILLION

Jacobs is delivering the full-scale Advanced Water Purification Facility including **major pumping, electrical, and control system infrastructure** integrated into the existing water reclamation plant.

### CLIENT REFERENCE

**Ryan Thiha, PE – Los Angeles Sanitation and Environment**  
ryan.thiha@lacity.org, 323-342-6229  
6100 Woodley Avenue, Van Nuys, CA 91406

**Jesus Gonzalez – Los Angeles Department of Water and Power**  
111 N. Hope St. Los Angeles, CA 90012  
jesus.gonzalez@ladwp.com, 213-367-1120



### PUMP STATIONS & CONVEYANCE SCOPE

- Design and integration of the **Balboa Pump Station** and **Sepulveda Pump Station**, which convey advanced treated water to the Hansen Spreading Grounds. Pumping systems engineered to support 30-45 million gallons per day, requiring:
  - High-reliability vertical turbine or horizontal pumping selections
  - Surge control strategies tied to variable flow patterns
  - Hydraulic routing, pump system balancing, and flow equalization integration

### ELECTRICAL DISTRIBUTION & POWER SYSTEMS SCOPE

The facility includes one of the most complex water-sector electrical systems in Southern California, featuring:

- New **medium-voltage service**, main switchgear, and distribution switchboards.
- Replacement and expansion of **motor control centers** for the pump stations, advanced treatment systems, and equalization basins.
- **Variable-frequency drives for all major pumping systems**, including harmonic mitigation and protective relaying.
- **Transformers, uninterruptible power supply, protective relays**, and grounding upgrades.
- Long-lead equipment procurement and integration into the Progressive Design-Build commercial structure.



**Woodland Davis Clean Water Agency (WDCWA) Regional Water Treatment Plant (RWTP), Woodland, CA - 30 MGD Regional Water Treatment Facility and treated water pump stations** - The project provides improved water supply reliability and water quality while assisting with cities compliance to strict state and federal water quality and wastewater discharge regulations.

### CONTROLS, AUTOMATION & SCADA SCOPE

- Facility-wide **programmable logic controller** modernization aligned with Los Angeles Department of Water and Power standards.
- Development of control narratives for pump station cycling, flow balancing, and advanced treatment response.
- Full **SCADA integration** across the advanced treatment, storage, and pumping systems ensuring consistent operator visibility and fail-safe operation.

### PHASED IMPLEMENTATION & MOPO REQUIREMENTS

Work is executed under a **Maintenance of Plant Operations (MOPO)** framework including:

- Multi-stage tie-ins of new electrical systems.
- Parallel construction next to active basins and pump stations.
- Temporary bypassing, isolation, and power maintenance for uninterrupted operation.

### PROJECT OUTCOMES

- Expanded purified water supply capacity.
- Minimized plant outages through advanced sequencing.
- Integrated pumping, treatment, electrical, and SCADA systems for long-term resilience.
- National award-winning design.

### KEY PERSONNEL

Mike Hwang, PE; Adam Nichols, PE; Qingshan Wang, PE; Gino Nguyen, PE; Jianwei Zhang, PE; Ping Tian, PE, GE

## Orange County Water District and City of Tustin PFAS Treatment System and Conveyance Project

Tustin, California | 2021 – In Construction | \$948,904

### CLIENT REFERENCE

**Fernando Almario – Project Manager, Orange County Water District**  
falmario@ocwd.com, 714-378-8220  
18700 Ward St., Fountain Valley, CA 92708

Jacobs designed and supported construction for a centralized treatment and pumping facility integrating multiple wellfields and new electrical/control systems.

### PUMP STATION & CONVEYANCE SCOPE

- Over **11,000 linear feet of new raw-water pipelines and 2,000 linear feet of distribution piping** designed to supply and discharge flow from four well sources.
- Upgrades to the existing **onsite booster pump station** were designed to provide complete replacement of existing 60 HP, 900 gpm pumps, with five, new, 200 HP pumps with 8,000 gpm of total finished water pumping capacity. The new pump station improves system reliability and accommodates varying flow and pressure conditions associated with multi-well operation. Hydraulic evaluations were conducted to optimize flow distribution across treatment trains and ensure consistent performance under variable operating scenarios.

### ELECTRICAL DISTRIBUTION SCOPE

- Complete **replacement of the main switchboard** to accommodate new pumping and treatment loads.
- **Motor control center replacement** sized for all booster pumps, PFAS treatment systems, nitrate removal systems, and chemical systems.
- Integration of new lighting panels, branch circuits, conduit/wire, and site power improvements.
- Coordination with **Southern California Edison** for electrical service modifications.

### CONTROLS & SCADA SCOPE

- Full migration from aging SLC 5/04 controllers to modern **CompactLogix programmable logic controllers** utilizing a device-level ring network.
- New distributed I/O, communication architecture, and programming.
- Unified supervisory control and data acquisition integration of wells, pumps, chemical systems, and ion-exchange processes.

### PHASED IMPLEMENTATION & TEMPORARY POWER

- Detailed phasing to keep existing wells in service during construction.
- Temporary power strategies to maintain pumping during motor control center replacement.
- Sequencing of pipeline tie-ins, switchboard changes, and cutovers to minimize disruption.

### PROJECT OUTCOMES

- **Achieved regulatory compliance under tight timelines.**
- **Improved system reliability, pumping performance, and treatment redundancy.**
- **Delivered a scalable PFAS treatment facility supporting future regulatory needs.**

### KEY PERSONNEL

Marrielle Coquia, PE; Michael Hwang, PE; Adam Nichols, PE; Michael Wang, PE; Minette Lava, EIT; Qingshan Wang, PE; Jianwei Zhang, PE; Ping Tian, PE, GE

## Water Replenishment District of Southern California Goldsworthy Desalter Expansion and Brackish Wells

Torrance, California | 2012 – 2016 | \$550,000

### CLIENT REFERENCE

**Everett Ferguson, Jr., PG, CHG – Water Replenishment District of Southern California**  
eferguson@wrd.org, 562-275-4241  
4040 Paramount Blvd., Lakewood, CA 90712

### PUMP & WELL SYSTEM SCOPE

- Siting and design of **two high-capacity 2,200-gpm extraction wells**, including casing design, screen selection, pump sizing, and aquifer drawdown evaluation. Hydraulic and system modeling to ensure compatibility with existing conveyance and treatment facilities.
- Integration of new pumping infrastructure into the existing desalter system.

### ELECTRICAL & CONTROL SYSTEM SCOPE

- Electrical design for well power, pump control, and treatment facility integration.
- Condition assessment of reverse-osmosis system operation including cleaning frequency, pressure performance, and fouling trends.

### PROJECT OUTCOMES

- **Improved groundwater reliability.**
- **Enhanced system performance through hydraulic refinements.**
- **Provided both short-term operational improvements and long-term design recommendations based on membrane fouling studies.**

### KEY PERSONNEL

Adam Nichols, PE; Kurt Lind; Minette Lava, EIT; Ping Tian, PE, GE, Michael Hwang, PE; Michael Wang, PE



## San Diego County Regional Airport Authority San Diego International Airport – Airside Improvements

San Diego, California | 2009 – Ongoing | \$1.2 Billion Program

### CLIENT REFERENCE

**Robert Bolton, AIA – Director of Airport Design and Construction, San Diego County Regional Airport Authority**  
P.O. Box 82776, San Diego, CA 92138  
619-400-2935, rbbolton@san.org

### PUMP STATION SCOPE

- Design of stormwater pumping systems tied to a large underground cistern (~970,000 gallons).
- **Two independent pump sets with variable-frequency drives** designed to either:
  - Pump stormwater to the Central Utility Plant for reuse, or
  - Discharge to infiltration islands to avoid pollutant loading to San Diego Bay.
 Hydraulic modeling, transient response consideration, and pump control strategies.

### ELECTRICAL DISTRIBUTION SCOPE

- Extension and reinforcement of the **12-kilovolt primary electrical loop** to support new airside facilities.
- Installation of **switchboards, transformers, medium-voltage switchgear**, motor control centers, and variable-frequency drives for all major pumping systems.
- Integration of redundant power systems, uninterruptible power supply, and protection coordination.

### INSTRUMENTATION, CONTROLS & SCADA SCOPE

- Full **PLC-based control system design**, including device-level network architecture for resiliency.
- SCADA and building management system integration across pump stations and stormwater systems.
- Factory acceptance testing, site acceptance testing, commissioning, and operator training.

### PHASED IMPLEMENTATION & TEMPORARY POWER

- Pump station and electrical upgrades installed while maintaining uninterrupted airfield operations.
- Temporary power distribution and **cutover sequencing** to ensure zero-down-time transitions.

### PROJECT OUTCOMES

- **Implemented a resilient and sustainable stormwater reuse system.**
- **Maintained full airport operations during construction.**
- **Delivered coordinated pumping, electrical, and control systems for mission-critical airfield infrastructure.**

### KEY PERSONNEL

Adam Nichols, PE; Michael Wang, PE; Qingshan Wang, PE; Mike Hwang, PE



APPENDIX B

# Drawings List

**Jacobs**

Challenging today.  
Reinventing tomorrow.

# APPENDIX B - DRAWING'S LIST

IRWD | East Irvine Zone 3 to 4 Pump Station Rehabilitation Project

<b>DRAWING TITLE</b>		
<b>GENERAL</b>		
1	G-1	TITLE SHEET
2	G-2	LOCATION MAP & DRAWING INDEX
3	G-3	ABBREVIATIONS
4	G-4	CIVIL LEGEND & NOTES
5	G-5	STRUCTURAL NOTES
6	G-6	ARCHITECTURAL LIFE SAFETY PLAN
7	G-7	MECHANICAL LEGEND & NOTES
8	G-8	ELECTRICAL LEGEND 1
9	G-9	ELECTRICAL LEGEND 2
10	G-10	INSTRUMENTATION AND CONTROLS LEGEND 1
11	G-11	INSTRUMENTATION AND CONTROLS LEGEND 2
<b>CIVIL</b>		
12	C-1	OVERALL SITE PLAN
13	C-2	PUMP STATION SITE PLAN
14	C-3	STANDARD DETAILS
<b>DEMOLITION</b>		
15	D-1	DEMOLITION PLAN
16	D-2	DEMOLITION DETAILS
<b>STRUCTURAL</b>		
17	S-1	CANOPY ROOF AND FOUNDATION PLANS
18	S-2	CANOPY STRUCTURE SECTIONS AND DETAILS
19	S-3	HATCH REPLACEMENT DETAILS
20	S-4	STANDARD STRUCTURAL DETAILS
<b>PROCESS MECHANICAL</b>		
21	M-1	PUMP STATION PLAN
22	M-2	PUMP STATION SECTIONS
23	M-3	MECHANICAL DETAILS
24	M-4	STANDARD MECHANICAL DETAILS 1
25	M-5	STANDARD MECHANICAL DETAILS 2
<b>ELECTRICAL</b>		
26	E-1	ELECTRICAL SITE PLAN
27	E-2	ELECTRICAL DEMOLITION PLAN
28	E-3	ONE-LINE DIAGRAM
29	E-4	SWITCHGEAR & MCC ELEVATIONS, AND PANEL SCHEDULES
30	E-5	PUMP STATION POWER PLAN
31	E-6	PUMP STATION LIGHTING AND GROUNDING PLAN
32	E-7	CONDUIT AND DUCTBANK SCHEDULES
33	E-8	CONTROL SCHEMATIC DIAGRAMS 1
34	E-9	CONTROL SCHEMATIC DIAGRAMS 2
35	E-10	STANDARD ELECTRICAL DETAILS
<b>INSTRUMENTATION</b>		
36	I-1	CONTROL PANEL LAYOUT AND BILL OF MATERIALS
37	I-2	CONTROL PANEL - POWER DISTRIBUTION
38	I-3	PUMP STATION P&ID 1
39	I-4	PUMP STATION P&ID 2
40	I-5	INSTRUMENTATION DETAILS



APPENDIX C

# Schedule

**Jacobs**

Challenging today.  
Reinventing tomorrow.

# APPENDIX C - SCHEDULE

IRWD | East Irvine Zone 3 to 4 Pump Station Rehabilitation Project

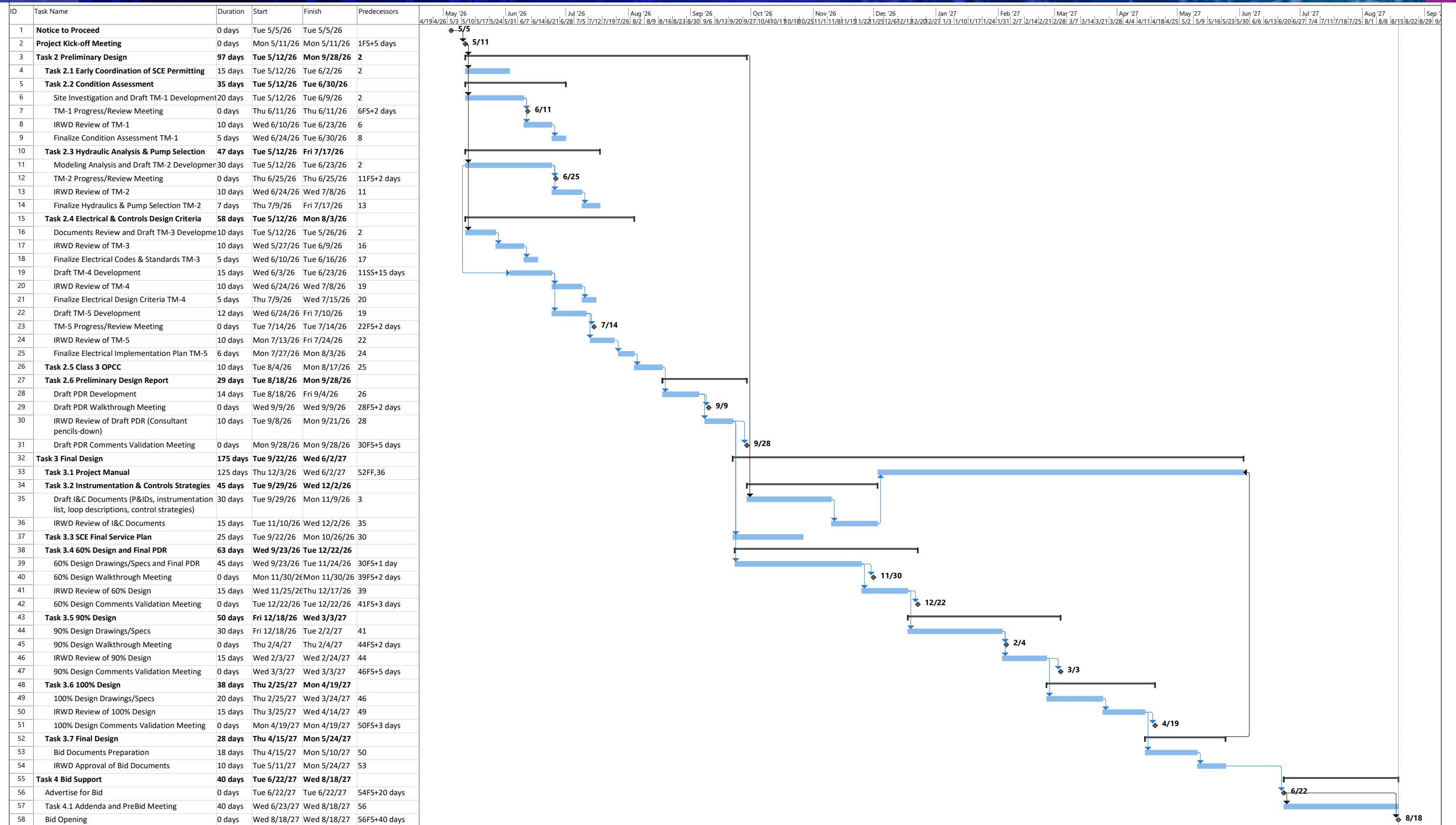

Project: East Irvine Zone 3 to 4 PS Rehab  
Date: Tue 3/17/26

Task	Summary	Inactive Milestone	Duration-only	Start-only	External Milestone	Manual Progress
Split	Project Summary	Inactive Summary	Manual Summary Rollup	Finish-only	Deadline	
Milestone	Inactive Task	Manual Task	Manual Summary	External Tasks	Progress	

The image shows an industrial control room. In the foreground, there is a white folding table with several documents and a clipboard on it. Behind the table, there are several large, grey electrical control panels mounted on a wall. The panels have various buttons, switches, and indicator lights. One panel has a prominent red emergency stop button. To the right, there are vertical pipes and conduits, and a fire extinguisher is visible. The overall lighting is dim, with a blue tint on the left side of the image.

APPENDIX D

# Level of Effort

**Jacobs**

Challenging today.  
Reinventing tomorrow.

# APPENDIX D - LEVEL OF EFFORT

IRWD | East Irvine Zone 3 to 4 Pump Station Rehabilitation Project

Task No.	Team Member Name, Role on Project Billing Classification	R. Nagel, Principal-in-Charge Principal-in-Charge	M. Coquia, PM Principal Professional 2	D. Ding, DM Principal Professional 1	M. Hwang, STC or QA/QC Principal Professional 1	Q. Wang, Mechanical Principal Professional 2	M. Meng, Structural Principal Professional 1	R. Yu, Hydraulics Principal Professional 2	P. Tian, Geotechnical Principal Professional 1	G. Nguyen, Civil Principal Professional 1	A. Nichols, Elec / I&C Principal Professional 1	F. Gist, Security Principal Professional 2	R. Smith, Architectural Principal Professional 1	L. Minette, Project Engineer (Civil) Staff Professional 2	J. Zhang, Project Engineer (Mechanical) Sr. Professional 1	D. Singh, Project Engineer (Electrical) Staff Professional 2	GID, Project Engineer (Instrumentation) Staff Professional 2	K. Nielsen, Project Engineer (Hydraulics) Principal Professional 2	J. Minor, Digital Delivery Lead Proj. Professional 1	GID, Structural/Arch CAD Technician	D. Patel, Civil CAD Technician	D. Cave, Mech CAD Engineering Technician	K. Wolny, Mech CAD Technician	R. Sharma, E/I CAD Technician	K. Butcher, Cost Estimator Proj. Professional 1	C. Perrine, Specs Processor Proj. Professional 1	TBD, Admin Admin/Clerical	LABOR HOURS SUBTOTAL	
<b>1.0</b>	<b>Project Management</b>																												
1.1	Preparation of Project Status Reports	2	36																										38
1.2	Project Design Schedule (Monthly)		16	24																									40
1.3	Meetings/Workshops (total of 29)		62	16	4	36	20	22		20	40		4														31	255	
	<b>TASK 1 SUBTOTAL</b>	<b>2</b>	<b>114</b>	<b>40</b>	<b>4</b>	<b>36</b>	<b>20</b>	<b>22</b>	<b>0</b>	<b>20</b>	<b>40</b>	<b>0</b>	<b>4</b>	<b>0</b>	<b>0</b>	<b>0</b>	<b>0</b>	<b>0</b>	<b>0</b>	<b>0</b>	<b>0</b>	<b>0</b>	<b>0</b>	<b>0</b>	<b>0</b>	<b>0</b>	<b>0</b>	<b>31</b>	<b>333</b>
<b>2.0</b>	<b>Preliminary Design</b>																												
2.1	Background Information Research					4				2	4		2																12
2.2	Early Coordination for SCE Permitting										12																		12
2.3	Condition Assessment (TM 1)		4		4	20	4				4																2	38	
2.4	Hydraulic Analysis		4		4	4		40										40									2	94	
2.5	Pump Selection (TM 2)					4		8																				12	
2.6	Electrical & Controls Design Criteria (TMs 3-5)		4		4						36																6	50	
2.7	Structural/Architectural		4				18						14															36	
2.8	Site Security Improvements		4							6	8					8												26	
2.9	Construction Schedule		4	20		5	2				6																	37	
2.10	Class 3 OPCC		4			4	4	4		4	4														24	7	55		
2.11	Preliminary Design Report	2	22	22	22	40	8	8	3	8	70	8	4	20	43	32	32	8	13	15	18	23	23	78	24	7	10	532	
	<b>TASK 2 SUBTOTAL</b>	<b>2</b>	<b>50</b>	<b>42</b>	<b>34</b>	<b>81</b>	<b>36</b>	<b>60</b>	<b>3</b>	<b>20</b>	<b>144</b>	<b>8</b>	<b>20</b>	<b>20</b>	<b>43</b>	<b>40</b>	<b>32</b>	<b>48</b>	<b>13</b>	<b>15</b>	<b>18</b>	<b>23</b>	<b>23</b>	<b>78</b>	<b>24</b>	<b>7</b>	<b>20</b>	<b>904</b>	
<b>3.0</b>	<b>Final Design</b>																												
3.1	Project Manual		8	8	8	12	12			12	40																	100	
3.2	I&C Strategies										24						8											32	
3.3	SCE Final Service Plan									8	16																	24	
3.4	60% Design (including OPCC)	4	20	20	24	24	24	6	2	8	42		4	28	30	28	24		13	18	24	18	18	58	24	12	11	484	
3.5	90% Design (including OPCC & Construction Schedule)	2	28	24	25	26	24	4	2	8	42		4	28	30	28	24		13	18	24	18	18	60	24	12	11	497	
3.6	100% Design (including OPCC)		56	48	42	24	24	6	3	6	76		9	36	20	52	44		35	30	36	18	18	136	64	28	28	839	
3.7	Final Design		20	24	22	10	18		2	8	40		4	20	30	28	20		13	14	18	14	13	58	24	10	10	420	
	<b>TASK 3 SUBTOTAL</b>	<b>6</b>	<b>132</b>	<b>124</b>	<b>121</b>	<b>96</b>	<b>102</b>	<b>16</b>	<b>9</b>	<b>50</b>	<b>280</b>	<b>0</b>	<b>21</b>	<b>112</b>	<b>110</b>	<b>136</b>	<b>120</b>	<b>0</b>	<b>74</b>	<b>80</b>	<b>102</b>	<b>68</b>	<b>67</b>	<b>312</b>	<b>136</b>	<b>62</b>	<b>60</b>	<b>2396</b>	
<b>4.0</b>	<b>Bid Support</b>																												
4.1	Addenda and PreBid Meeting	2	16	8	4	20	12	8		8	24																	102	
	<b>TASK 4 SUBTOTAL</b>	<b>2</b>	<b>16</b>	<b>8</b>	<b>4</b>	<b>20</b>	<b>12</b>	<b>8</b>	<b>0</b>	<b>8</b>	<b>24</b>	<b>0</b>	<b>0</b>	<b>0</b>	<b>0</b>	<b>0</b>	<b>0</b>	<b>0</b>	<b>0</b>	<b>0</b>	<b>0</b>	<b>0</b>	<b>0</b>	<b>0</b>	<b>0</b>	<b>0</b>	<b>0</b>	<b>102</b>	
<b>5.0</b>	<b>OPTIONAL</b>																												
5.1	Optional: Task 2.12 CFD Analysis of Pump Intakes	2	2		2	4		8										120										138	
	<b>TASK 5 SUBTOTAL</b>	<b>2</b>	<b>2</b>	<b>0</b>	<b>2</b>	<b>4</b>	<b>0</b>	<b>8</b>	<b>0</b>	<b>0</b>	<b>0</b>	<b>0</b>	<b>0</b>	<b>0</b>	<b>0</b>	<b>0</b>	<b>0</b>	<b>120</b>	<b>0</b>	<b>0</b>	<b>0</b>	<b>0</b>	<b>0</b>	<b>0</b>	<b>0</b>	<b>0</b>	<b>0</b>	<b>138</b>	
	<b>TOTAL (TASKS 1-4)</b>	<b>12</b>	<b>312</b>	<b>214</b>	<b>163</b>	<b>233</b>	<b>170</b>	<b>106</b>	<b>12</b>	<b>98</b>	<b>488</b>	<b>8</b>	<b>45</b>	<b>132</b>	<b>153</b>	<b>176</b>	<b>152</b>	<b>48</b>	<b>87</b>	<b>95</b>	<b>120</b>	<b>91</b>	<b>90</b>	<b>390</b>	<b>160</b>	<b>69</b>	<b>111</b>	<b>3735</b>	
	<b>TOTAL W/OPTIONAL TASK (TASKS 1-5)</b>	<b>14</b>	<b>314</b>	<b>214</b>	<b>165</b>	<b>237</b>	<b>170</b>	<b>114</b>	<b>12</b>	<b>98</b>	<b>488</b>	<b>8</b>	<b>45</b>	<b>132</b>	<b>153</b>	<b>176</b>	<b>152</b>	<b>168</b>	<b>87</b>	<b>95</b>	<b>120</b>	<b>91</b>	<b>90</b>	<b>390</b>	<b>160</b>	<b>69</b>	<b>111</b>	<b>3,873</b>	



APPENDIX F

# Statements for Joint Venture, Public Works Requirement & Conflict of Interest

**Jacobs**

Challenging today.  
Reinventing tomorrow.

# APPENDIX F - STATEMENTS FOR JOINT VENTURE, PUBLIC WORKS REQUIREMENT, AND CONFLICT OF INTEREST

IRWD | East Irvine Zone 3 to 4 Pump Station Rehabilitation Project

## JOINT VENTURE/SUBCONSULTANT ARRANGEMENTS

Jacobs is submitting this proposal as the sole prime consultant. No joint venture is proposed, and Jacobs is not proposing any subcontract or subconsultant arrangements for this project. If any change to this approach becomes necessary during performance of the work, Jacobs understands that subcontracting or subconsulting would require IRWD's prior written approval.

## PUBLIC WORK REQUIREMENT

Jacobs understands that portions of the Project may be deemed "public work" under California law, including certain geotechnical, surveying, inspection, or similar services. Jacobs will comply with IRWD's public work requirements and, for any firm performing such work, will provide the firm name and applicable DIR registration number in the proposal. Jacobs will also verify that any applicable subconsultants or subcontractors performing public work maintain current DIR registration and comply with all associated statutory requirements for the duration of that work. The Jacobs DIR# is 1000057877.

## CONFLICT OF INTEREST STATEMENT

To the best of our knowledge, Jacobs is not aware of any personal or organizational conflict of interest prohibited by law related to this Project. Jacobs will comply with applicable conflict of interest requirements and will promptly disclose any actual or potential conflict identified during the course of the work.

PROJECT MANAGER

**Marielle Coquia, PE**

E: [Marielle.Coquia@jacobs.com](mailto:Marielle.Coquia@jacobs.com)

P: 949.224.7626

April 30, 2026

Brian Waite, P.E.  
Engineering Manager – Treatment & Conveyance  
Irvine Ranch Water District  
15600 Sand Canyon Avenue  
Irvine, CA 92618

## **Subject: Addendum to Proposal for Engineering Design Services for the East Irvine Zone 3 to 4 Pump Station Rehabilitation Project (PR 12565)**

Dear Mr. Waite:

Jacobs appreciates the opportunity to submit this Addendum to Jacobs' proposal to support Irvine Ranch Water District with engineering design services for the East Irvine Zone 3 to 4 Pump Station Rehabilitation Project.

### **We have provided clarifications to the following items:**

1. Your proposal outlines a comprehensive condition assessment approach, including TM-1 and coordination with O&M staff; however, your level of effort appears lower than anticipated. Can you walk us through your assumptions regarding the depth of field investigation, number of site visits, and staff hours allocated to fully evaluate all assets?
  - Condition assessment assumed to be non-invasive visual inspections and interviewing with Operations and Maintenance staff. No performance tests are assumed.
  - One (1) dedicated site visit assumed for the condition assessment. IRWD will remove the pumps and coordinate site safety procedures.
  - An Asset register, safety admin, loading system into ACES condition assessment tool, and preparation of Technical Memorandum which will report findings
  - Jacobs included an allowance to account for additional field investigation (2 visits assumed) if deemed necessary during the condition assessment. It also includes engineering efforts to incorporate potential rehabilitation work at the pump station, such as pump cans and the suction header. It is assumed that existing pump intake piping configuration and sizes do not require changes. The additional work will be performed upon approval by IRWD.
2. The preliminary design phase includes multiple technical memorandums (TM-1 through TM-5), hydraulic modeling, phasing analysis, and development of the PDR. Can you clarify how your proposed hours support these deliverables and whether any efficiencies or assumptions are driving the reduced level of effort compared to similar projects?
  - Jacobs included an allowance for considering unforeseen conditions as mentioned above as well as increased a level of effort for subject matter experts (SME) as part of QA/QC and constructability review at the milestone deliveries in PDR and Final Design phases.
  - As suggested by IRWD, Jacobs assumed greater efforts in the preliminary design phase (i.e., Task 2.0) and, therefore, reallocated a portion of the labor hours from the final design tasks to preliminary design.
3. The RFP requested an anticipated list of technical specifications, which doesn't appear to be included in your proposal. Can you clarify your assumptions for the level of effort associated with specification development, including how this effort is allocated between the preliminary and final design phases, and confirm that it is fully captured in your proposed fee?
  - IRWD's standard specifications (as included in the Construction Manual and Project Manual) to be evaluated and

modified for use in the Project. For project-specific specifications not included in IRWD standards, Jacobs will develop them as needed to deliver a complete and biddable design. We have attached a proposed list of Jacobs' Technical Specifications which was not included in the proposal. A portion of the increased level of effort accounts for additional QC in specifications to ensure compatibility and coordination of sections from different sources.

We have included an updated list of Scope Assumptions and revised Level of Effort Fee Estimate for your consideration and is attached to this letter. The updated service Fee is **\$896,569 without the optional task and \$938,942, with the optional task.**

We appreciate the opportunity to support IRWD and look forward to working closely with your Engineering and Operations teams. If you have any questions or need additional information, please contact Marielle Coquia, PE at 949.224.7626 or [marielle.coquia@jacobs.com](mailto:marielle.coquia@jacobs.com).

Sincerely,



**Marielle Coquia, PE**  
Project Manager  
[marielle.coquia@jacobs.com](mailto:marielle.coquia@jacobs.com)  
949.224.7626

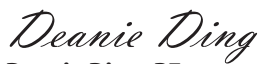

**Deanie Ding, PE**  
Design Manager  
[deanie.ding@jacobs.com](mailto:deanie.ding@jacobs.com)  
949.224.7805



**Rich Nagel, PE**  
Principal-in-Charge  
[rich.nagel@jacobs.com](mailto:rich.nagel@jacobs.com)  
213.228.8227

## Assumptions

- Maximum outage window limited to approximately 2 days per major tie-in.
- Major mechanical equipment replacement assumed unless condition assessment determines otherwise.
- No modifications to existing pump station inlet header system under the slab.
- **Condition assessment assumed to be non-invasive visual inspections and interviewing with Operations and Maintenance staff. No performance tests assumed.**
- **One (1) dedicated site visit assumed for the condition assessment. IRWD will remove the pumps and coordinate site safety procedures.**
- The existing hydraulic model in InfoWater is up-to-date and calibrated to represent existing distribution networks.
- Reuse of existing buried conduits at pump station pad.
- Pump motor starter replacement assumed constant speed control; no VFDs included unless directed.
- Canopy to include new lighting.
- No changes to existing solar PV system unless directed.
- No building structural modifications included beyond the addition of a new canopy and hatch improvements.
- Surge analysis performed at engineering modeling level; advanced CFD for transient modeling not included.
- Permit fees reimbursed per RFP allowance. IRWD will coordinate and provide topographic mapping services to support civil improvements related to canopy installation, perimeter fence installation, and concrete pads.
- Implementation and integration of security cameras not included.
- No changes to site grading or drainage system.
- Topographic map of current conditions will be provided in AutoCAD platform will be provided by IRWD. If additional or updated topographic data is required to complete designs, IRWD will coordinate and obtain current topographic mapping to provide to Jacobs.
- **Included an allowance to account for additional field investigation (2 visits assumed) if deemed necessary during the condition assessment. It also includes engineering efforts to incorporate potential rehabilitation work at the pump station, such as pump cans and the suction header. It is assumed that existing pump intake piping configuration and sizes do not require changes. The additional work will be performed upon approval by IRWD.**
- **IRWD's standard specifications (as included in the Construction Manual and Project Manual) to be evaluated and modified for use in the Project. For project-specific specifications not included in IRWD standards, Jacobs will develop them as needed to deliver a complete and biddable design.**
- Deliverables will be submitted in the formats specified in the RFP.
- Per the RFP, the scope of services extends through bid services and does not include engineering services during the construction phase. Jacobs can offer services during construction (SDC) to IRWD, which would typically include submittal/shop drawing review, responses to requests for information (RFIs), preparation of design change notices (DCNs) and preparation of record drawings. If desired, Jacobs can provide a scope and fee for these services based on further discussions with IRWD, if appropriate at this stage in the project.



# LIST OF SPECS

IRWD | East Irvine Zone 3 to 4 Pump Station Rehabilitation Project

NO.	SPECIFICATION TITLE	REMARKS
<b>DIVISION 01 - GENERAL REQUIREMENTS</b>		
01045	Existing Facilities	IRWD Standard
01130	Dewatering	IRWD Standard
01200	Requests for Information (RFI)	IRWD Standard
01300	Submittal Procedures	Jacobs Developed
01400	Preconstruction and Post Construction Conferences	IRWD Standard
01410	Construction Safety Procedures	IRWD Standard
01420	Confined Spaces	IRWD Standard
01430	Operation and Maintenance Data	Jacobs Developed
01440	Temporary Facilities and Controls	IRWD Standard
01510	Testing, Training, and Facility Startup	IRWD Standard
01520	Closeout Procedures	IRWD Standard
01640	Manufacturers' Services	Jacobs Developed
01611	Seismic Anchorage and Bracing	Jacobs Developed
01840	Basis of Measurement for Payment	IRWD Standard
<b>DIVISION 02 - SITEWORK</b>		
02220	Demolition	Jacobs Developed
02223	Trenching, Backfilling, and Compacting	IRWD Standard
02528	Concrete Curbs, Gutters, and Sidewalks	IRWD Standard
02578	Pavement Removal and Replacement	IRWD Standard
02821	Fences and Gates	Jacobs Developed
<b>DIVISION 03 - CONCRETE</b>		
01300	Concrete Formwork	IRWD Standard
03201	Concrete Reinforcement	IRWD Standard
03300	Cast-In-Place Concrete	IRWD Standard
03600	Grout	Jacobs Developed
<b>DIVISION 05 - METALS</b>		
05050	Welding	Jacobs Developed
05120	Structural Steel and Miscellaneous Metalwork	IRWD Standard
05310	Steel Decking	Jacobs Developed
05500	Metal Fabrications	Jacobs Developed
05519	Post-Installed Anchors	Jacobs Developed
<b>DIVISION 09 - FINISHES</b>		
09900	Painting and Coating	IRWD Standard
<b>DIVISION 11 - EQUIPMENT</b>		
11212	Vertical Turbine Pumps	Jacobs Developed
11371	Compressed Air Systems	Jacobs Developed
<b>DIVISION 13 - SPECIAL CONSTRUCTION</b>		
13210	Hydropneumatic Tank and Accessories	Jacobs Developed
<b>DIVISION 15 - MECHANICAL</b>		
15040	Interior Inspection for Cement-Mortar Line Steel Pipe	IRWD Standard
15041	Chlorination of Water Mains, Wells and Reservoirs	IRWD Standard
15042	Hydrostatic Testing of Pressure Pipelines	IRWD Standard
15051	Installation of Pressure Pipelines	IRWD Standard
15053	Carbon Steel Pipe and Fittings	IRWD Standard
15056	Ductile-Iron Pipe and Fittings	IRWD Standard

# LIST OF SPECS

IRWD | East Irvine Zone 3 to 4 Pump Station Rehabilitation Project

NO.	SPECIFICATION TITLE	REMARKS
<b>DIVISION 15 - MECHANICAL</b>		
15057	Copper Pipe and Fittings	IRWD Standard
15060	Piping Support Systems (Contractor-Designed)	Jacobs Developed
15064	PVC Pressure Pipe and Fittings	IRWD Standard
15089	Combination Air Release and Vacuum Relief Valves	IRWD Standard
15100	Manual Valves	IRWD Standard
15151	Facility Identification	IRWD Standard
15162	Flexible Pipe Couplings and Expansion Joints	IRWD Standard
15205	Process Piping Specialties	Jacobs Developed
15209	Surge Control System	Jacobs Developed
<b>DIVISION 16 - ELECTRICAL</b>		
16010	General Electrical Requirements	IRWD Stanadard
16051	Miscellaneous Electrical Devices	IRWD Stanadard
16110	Raceways, Pull Boxes, and Fittings	IRWD Stanadard
16120	Conductors and Cables	IRWD Stanadard
16135	Cabinets and Enclosures	IRWD Stanadard
16140	Switches and Receptacles	IRWD Stanadard
16220	Low-Voltage AC Induction Motors	Jacobs Developed
16288	Surge Protective Devices	Jacobs Developed
16400	Service and Distribution?	IRWD Stanadard
16440	Low-Voltage Motor Control	Jacobs Developed
16450	Grounding	IRWD Stanadard
16455	Switchboards	Jacobs Developed
16500	Lighting	Jacobs Developed
16900	Power Measurement and Control	Jacobs Developed
16950	Electrical Testing	IRWD Stanadard
<b>DIVISION 17 - INSTRUMENTATION</b>		
17000	General Instrumentation Control Requirements	IRWD Standard
	Supplement 01 PLC Input/Output List	IRWD Standard
	Supplement 02 Instrument List Summary	IRWD Standard
	Supplement 03 Control Strategies	Jacobs Developed
17110	Identification Tags	IRWD Standard
17402	Instrumentation and Control Components	Jacobs Developed

Note: This page is intentionally left blank.