

**AGENDA  
IRVINE RANCH WATER DISTRICT  
BOARD OF DIRECTORS  
REGULAR MEETING**

May 26, 2026

**CALL TO ORDER** 5:00 p.m.

**PLEDGE OF ALLEGIANCE**

**ROLL CALL** Directors Ferons, Reinhart, Swan, Withers, and President LaMar

Director Ferons will participate via teleconference from 1605 Royal Pine Court, Leland, NC 28451.

**PUBLIC COMMENT NOTICE**

This meeting will be held in-person at the District’s headquarters located at 15600 Sand Canyon Avenue, Irvine, California. The meeting will also be broadcasted via Webex for those wanting to observe the meeting virtually.

To observe this meeting virtually, please join online using the link and information below:

Via Web: <https://irwd.webex.com/irwd/j.php?MTID=m10d15ff1dbadcb9c54bc2c8e0aafea69>

Meeting Number (Access Code): **2482 314 0985**

Meeting Password: **fxEtyWUw863**

*PLEASE NOTE: Webex observers of the meeting will be placed into the Webex lobby when the Board enters closed session. Participants who remain in the “lobby” will automatically be returned to the open session of the Board once the closed session has concluded. Observers joining the meeting while the Board is in closed session will receive a notice that the meeting has been locked. They will be able to observe the meeting once the closed session has concluded.*

Public comments are limited to three minutes per speaker on each subject. If you wish to address the Board of Directors orally on any item, you may attend the meeting in person and submit a “speaker slip” to the Secretary. Forms are provided outside of IRWD’s Board Room. If you wish to submit written comments to the Board, please submit your public comment in advance of the meeting by emailing [comments@irwd.com](mailto:comments@irwd.com) before 12:00 p.m. the day of the meeting, and your remarks will be added to the record at the meeting.

---

**COMMUNICATIONS TO THE BOARD**

---

1. Written:

2. Oral:

3. ITEMS RECEIVED TOO LATE TO BE AGENDIZED

Recommendation: Determine the need to discuss and/or take immediate action on item(s).

---

**PRESENTATION**

---

4. PROCLAMATION

A proclamation will be presented to Mrs. Diane Squyres for her years of service to the District.

---

**CONSENT CALENDAR, Items 5 through 14**

---

5. BOARD MEETING MINUTES  
Recommendation: That the minutes of the April 27, 2026 Regular Board meeting be approved as presented.
6. APRIL 2026 TREASURY REPORT  
Recommendation: That the Board receive and file the Treasurer's Investment Summary Report, the Summary of Fixed and Variable Rate Debt, and the Disclosure Report of Reimbursements to Board members and staff, approve the April 2026 Summary of Payroll ACH payments in the total amount of \$2,898,781 and approve the April 2026 accounts payable disbursement summary of warrants 454518 through 455102, Workers' Compensation distributions, ACH payments, virtual card payments, wire transfers, payroll withholding distributions, and voided checks in the net total amount of \$21,900,467.
7. 2026 LEGISLATIVE AND REGULATORY UPDATE  
Recommendation: That the Board adopt a "WATCH" position on SB 1001 (Archuleta).
8. REGISTRAR OF VOTERS INFORMATION REQUEST AND CANDIDATE STATEMENT WORD LIMIT FOR THE ELECTION OF THE BOARD OF DIRECTORS  
Recommendation: That the Board authorize the District Secretary to file the "Transmittal of Election Information" form for each general election confirming IRWD's political and division boundaries, providing the Registrar of Voters with the requested information, selecting a 200-word limit for Candidate Statements of Qualifications, and indicating that IRWD will not pay for the Statements of Qualifications.
9. WATER EFFICIENCY TACTICAL INCENTIVE FUNDING AUTHORIZATION  
Recommendation: That the Board authorize the General Manager to allocate \$877,000 in funding to the Fiscal Year 2026-27 tactical incentive programs administered through the Water Conservation Participation Agreement between Municipal Water District of Orange County and Irvine Ranch Water District; and to execute addenda to the agreement, as may be necessary, to allocate funds to specific programs and modify device incentive levels based on customer participation rates and regional program funding levels.

---

**CONSENT CALENDAR, Items 5 through 14, continued**

---

10. MICHELSON WATER RECYCLING PLANT SOLIDS HANDLING IMPROVEMENTS VARIANCE AND BUDGET INCREASE

Recommendation: That the Board authorize a budget increase in the amount of \$10,670,000, from \$1,065,000 to \$11,735,000, and authorize the General Manager to approve Variance No. 1 with Carollo Engineers, Inc. in the amount of \$394,974 for additional engineering design services for the Michelson Water Recycling Plant Solids Handling Improvements, Project 12555.

11. FISCAL YEAR 2026-27 PIPELINE REPLACEMENT PROJECT ADDITIONS

Recommendation: That the Board authorize the addition of the Warner Avenue Recycled Water Pipeline Replacement, Project 13560 in the amount of \$2,310,000 to the FY 2026-27 Capital Budget; authorize the addition of the Portola Springs Domestic Water Pipeline Rehabilitation, Project 13651 in the amount of \$3,778,000 to the FY 2026-27 Capital Budget; authorize the addition of the Portola Springs Recycled Water Pipeline Rehabilitation, Project 13562 in the amount of \$3,512,000 to the FY 2026-27 Capital Budget; and authorize the addition of the University Park Domestic Water Pipeline Replacement, Project 13563 in the amount of \$4,480,000 to the FY 2026-27 Capital Budget.

12. FISCAL YEARS 2025-26 GENERAL REPLACEMENTS AND MODIFICATIONS PROJECTS BUDGET INCREASES

Recommendation: That the Board authorize a budget increase for Project 12521 in the amount of \$1,417,000, from \$6,283,000 to \$7,700,000; authorize a budget increase for Project 12523 in the amount of \$497,000, from \$2,103,000 to \$2,600,000; and authorize a budget increase for Project 12525 in the amount of \$1,315,000, from \$1,785,000 to \$3,100,000, for the Fiscal Year 2025-26 General System Replacements and Modifications projects.

13. ESRI GIS ENTERPRISE AGREEMENT, AMENDMENT NO. 1

Recommendation: That the Board authorize the General Manager to execute Amendment No. 1 to Esri Enterprise Agreement No. 00315535.0 to add \$750,000 and extend the term by three years, from May 23, 2026 through May 22, 2029.

14. RESOLUTION AUTHORIZING INITIATION OF AN ORANGE COUNTY LOCAL AGENCY FORMATION COMMISSION PROCEEDING FOR THE ANNEXATION OF THE LOS ALISOS WATER RECYCLING PLANT AREA INTO THE ORANGE COUNTY SANITATION DISTRICT

Recommendation: That the Board adopt the following resolution by title:

RESOLUTION NO. 2026 – 4

RESOLUTION OF THE BOARD OF DIRECTORS OF THE IRVINE RANCH WATER DISTRICT AUTHORIZING INITIATION OF PROCEEDINGS AND REQUESTING THE ORANGE COUNTY LOCAL AGENCY FORMATION COMMISSION TO UNDERTAKE PROCEEDINGS FOR THE ANNEXATION OF THE LOS ALISOS AREA INTO THE ORANGE COUNTY SANITATION DISTRICT

Reso. 2026-4

---

**ACTION CALENDAR**

---

15. EAST IRVINE ZONE 3-4 PUMP STATION REHABILITATION  
CONSULTANT SELECTION AND BUDGET ADJUSTMENT

Recommendation: That the Board authorize a budget increase in the amount of \$3,780,000, from \$2,500,000 to \$6,280,000, and authorize the General Manager to execute a Professional Services Agreement with Jacobs in the amount of \$938,942 for engineering design services for the East Irvine Zone 3-4 Pump Station Rehabilitation, Project 12565.

16. SAN JOAQUIN DAM DRAINAGE IMPROVEMENTS BUDGET INCREASE  
AND CONSTRUCTION AWARD

Recommendation: That the Board authorize a budget increase for Project 13166 in the amount of \$853,000, from \$1,914,000 to \$2,767,000, and authorize the General Manager to execute a construction contract with Orion Construction Corporation in the amount of \$1,947,000 for the San Joaquin Dam Drainage Improvements, Project 13166.

---

**OTHER BUSINESS**

---

Pursuant to Government Code Section 54954.2, members of the Board of Directors or staff may ask questions for clarification, make brief announcements, and make brief reports on his/her own activities. The Board or a Board member may provide a reference to staff or other resources for information, request staff to report back at a subsequent meeting concerning any matter, or direct staff to place a matter of business on a future agenda. Such matters may be brought up under the General Manager's Report or Directors' Comments. Pursuant to AB 1234 and Government Code Section 53232.3(d), a written draft report of the meetings that any Board member attended on behalf of IRWD since the last Board Meeting will be available at the table near the Board Room entrance, and will be amended verbally, if necessary, during Directors' Comments.

- 17. General Manager's Report
- 18. Receive oral update(s) from District liaison(s) regarding communities within IRWD's service area and interests.
- 19. Directors' Comments and Meeting Reports
- 20. Adjournment

\*\*\*\*\*  
Availability of agenda materials: Agenda exhibits and other writings that are disclosable public records distributed to all or a majority of the members of the above-named Board in connection with a matter subject to discussion or consideration at an open meeting of the Board are available for public inspection in the District's office, 15600 Sand Canyon Avenue, Irvine, California ("District Office"). If such writings are distributed to members of the Board less than 72 hours prior to the meeting, they will be available from the District Secretary of the District Office at the same time as they are distributed to Board Members, except that if such writings are distributed one hour prior to, or during, the meeting, they will be available electronically via the Webex meeting noted. Upon request, the District will provide for written agenda materials in appropriate alternative formats, and reasonable disability-related modification or accommodation to enable individuals with disabilities to participate in and provide comments at public meetings. Please submit a request, including your name, phone number and/or email address, and a description of the modification, accommodation, or alternative format requested at least two days before the meeting. Requests should be emailed to comments@irwd.com. Requests made by mail must be received at least two days before the meeting. Requests will be granted whenever possible and resolved in favor of accessibility.

May 26, 2026  
Prepared and  
submitted by: K. Swan  
Approved by: Paul A. Cook *PAK*

CONSENT CALENDAR

BOARD MEETING MINUTES

SUMMARY:

Provided are the minutes of the April 27, 2026 Board of Directors meeting for approval.

FISCAL IMPACTS:

None.

ENVIRONMENTAL COMPLIANCE:

Not applicable.

COMMITTEE STATUS:

Not applicable.

RECOMMENDATION:

THAT THE MINUTES OF THE APRIL 27, 2026 BOARD OF DIRECTORS MEETING BE APPROVED AS PRESENTED.

LIST OF EXHIBITS:

Exhibit "A" – April 27, 2026 Minutes

Note: This page is intentionally left blank.

## Exhibit “A”

### MINUTES OF REGULAR MEETING – APRIL 27, 2026

The regular meeting of the Board of Directors of the Irvine Ranch Water District (IRWD) was called to order by President LaMar at 5:00 p.m. on April 27, 2026 at the District offices, 15600 Sand Canyon Avenue, Irvine.

Directors Present: Ferons, Reinhart, Withers and President LaMar.

Directors Absent: Swan.

Oral and Written Communications: An email from Director Swan regarding Agenda Item No. 12 was received and is provided as Attachment “A”.

Items too late to be agendized: None.

Also Present: General Manager Cook, Executive Director of Technical Services Burton, Executive Director of Operations Chambers, Executive Director of Water Policy Weghorst, Director of Water Resources Nye, Director of Water Quality Colston, Director of Human Resources Mitcham, Director of Water & Recycling Operations Zepeda, Director of Maintenance Operations Manning, Director of Safety and Security Choi, Director of Financial Planning and Data Analytics Smithson, Director of Accounting Lin, Recycled Water and Cross Connection Control Manager Hatch, Engineering Manager Akiyoshi, Engineering Manager Moeder, General Counsel Collins, Secretary Swan, members of the staff, and public.

### PRESENTATION

#### 4. SCIENCE FAIR AWARD WINNERS

The Community Relations staff hosted an open house of water-related projects entered in this year’s annual Irvine Unified School District Science Fair and presented awards to fifty-eight students.

### CONSENT CALENDAR

On MOTION by Reinhart, seconded by Withers, and unanimously carried, CONSENT CALENDAR ITEMS FIVE THROUGH ELEVEN WERE APPROVED AS FOLLOWS:

#### 5. BOARD MEETING MINUTES

Recommendation: That the minutes of the April 13, 2026 Board of Directors meeting be approved as presented.

#### 6. MARCH 2026 TREASURY REPORT

Recommendation: That the Board receive and file the Treasurer’s Investment Summary Report, the Summary of Fixed and Variable Rate Debt, and the Disclosure Report of Reimbursements to Board members and staff, approve the March 2026 Summary of Payroll ACH payments in the total amount of \$2,854,257, and approve the March 2026 accounts payable disbursement summary of warrants 454064 through 454517, Workers’ Compensation distributions, ACH payments, virtual card payments, wire transfers, payroll withholding distributions, and voided checks in the net total amount of \$15,364,666.

CONSENT CALENDAR (CONTINUED)

7. FISCAL YEAR 2025-26 IRWD GUIDING PRINCIPLES SCORECARD

Recommendation: Receive and file.

8. MEMORANDA OF UNDERSTANDING BETWEEN THE IRVINE RANCH WATER DISTRICT AND THE INTERNATIONAL BROTHERHOOD OF ELECTRICAL WORKERS (AFL-CIO) LOCAL #47 GENERAL UNIT AND NON-EXEMPT SUPERVISOR UNIT EMPLOYEES EFFECTIVE JULY 1, 2026 THROUGH JUNE 30, 2031

Recommendation: That the Board authorize the General Manager to execute the Memoranda of Understanding between the Irvine Ranch Water District and the International Brotherhood of Electrical Workers (AFL-CIO) Local #47 General Unit and the Non-exempt Supervisor Unit employees effective July 1, 2026 through June 30, 2031 subject to non-substantive changes.

9. EASTWOOD RECYCLED WATER PUMP STATION ZONE A TO SYPHON AND SYPHON TO ZONE C EQUIPPING CONSULTANT SELECTION AND BUDGET INCREASE

Recommendation: That the Board authorize a budget increase in the amount of \$2,622,900 and authorize the General Manager to execute a Professional Services Agreement with AECOM in the amount of \$786,640 for engineering design services for the Eastwood Recycled Water Pump Station Zone A to Syphon and Syphon to Zone C Equipping, Project 11831.

10. CITY OF IRVINE GREAT PARK NORTHERN SECTOR, CULTURAL TERRACE, AND GATEWAY RESIDENTIAL VILLAGE CAPITAL FACILITIES

Recommendation: That the Board authorize the General Manager to execute a Reimbursement Agreement with the City of Irvine for IRWD facilities related to the Great Park Northern Sector and Cultural Terrace Development; authorize the General Manager to accept the City of Irvine's construction contract with Sukut Construction, LLC in the amount of \$2,407,817 for the Great Park Framework Plan Capital Facilities project; authorize the addition of the Great Park Framework Plan Domestic Water Capital Facilities, Project 13463, in the amount of \$985,000 to the FY 2025-26 Capital Budget; authorize the addition of the Great Park Framework Plan Recycled Water Capital Facilities, Project 13464, in the amount of \$1,605,000 to the FY 2025-26 Capital Budget; authorize the addition of the Great Park Framework Plan Sanitary Sewer Capital Facilities, Project 13465, in the amount of \$867,000 to the FY 2025-26 Capital Budget; and authorize the General Manager to execute a Reimbursement Agreement with the City of Irvine for IRWD facilities related to the Gateway Residential Village Development.

11. HARDING CANYON DAM ALTERNATIVES ANALYSIS CONSULTANT SELECTION

Recommendation: That the Board authorize the General Manager to execute a Professional Services Agreement with Geosyntec, Inc. in the amount of \$277,700 for engineering design services for the Harding Canyon Dam Alternatives Analysis, Project 12513.

## ACTION CALENDAR

### 12. SYPHON RESERVOIR IMPROVEMENT PROJECT CONSULTANT SELECTIONS AND CONSTRUCTION AWARD

Engineering Manager Akiyoshi presented to the Board the Syphon Reservoir Improvement Project's strategic alignment with the District's Goals and Target Activities, as well as the costs, key assumptions, and a seasonal storage overview.

Director of Financial Planning and Data Analytics Smithson provided an updated projection of costs and use of bond sales for project financing.

Engineering Manager Moeder provided an extended timeline for the project, an overview of the selection process for the proposed consultants and the bidding process for the proposed contractor, details of other off-site projects that are related to the project, the schedule of the project, and the basis for the staff's recommendation to award consulting contracts to AECOM for engineering support during construction and to ESA for environmental compliance monitoring during construction, and to award a construction contract to Sukut Construction for the construction of the Syphon Reservoir Improvement Project.

General Manager Cook reminded the Board of Director Swan's email, and that it will be added to the record of the meeting.

Director Reinhart stated that the proposed consultant selection was reviewed by the Engineering and Operations Committee, and that the Committee supports the staff recommendation. Director Withers stated that he was very comfortable with the project, the consultant selection, and that the Syphon Reservoir will not only be an asset to the District, but a benefit for the future. On MOTION by Reinhart, seconded by Withers, and unanimously carried, THE BOARD AUTHORIZED A BUDGET INCREASE FOR PROJECT 03808 IN THE AMOUNT OF \$42,098,000, FROM \$291,000,000 TO \$333,098,000, AUTHORIZED THE GENERAL MANAGER TO EXECUTE A PROFESSIONAL SERVICES AGREEMENT WITH AECOM IN THE AMOUNT OF \$8,864,950 FOR ENGINEERING SUPPORT DURING CONSTRUCTION; AND AUTHORIZED THE GENERAL MANAGER TO EXECUTE A PROFESSIONAL SERVICES AGREEMENT WITH ESA IN THE AMOUNT OF \$3,990,644 IN SUPPORT OF ENVIRONMENTAL COMPLIANCE MONITORING DURING CONSTRUCTION; AND AUTHORIZED THE GENERAL MANAGER TO EXECUTE A CONSTRUCTION CONTRACT WITH SUKUT CONSTRUCTION IN THE AMOUNT OF \$214,126,000 FOR THE SYPHON RESERVOIR IMPROVEMENT PROJECT.

### 13. LOCAL RESOURCES PROGRAM FUNDING FOR SYPHON RESERVOIR IMPROVEMENT PROJECT

Recycled Water and Cross Connection Control Manager Hatch reported to the Board that staff has collaborated with the Municipal Water District of Orange County to prepare a Local Resources Program funding application to the Metropolitan Water District. If approved, IRWD could receive \$4.7 million over the first eight years of operation of the Syphon Reservoir Project.

Director Reinhart reported that this item was reviewed by the Engineering and Operations Committee, and that the Committee supports the staff recommendation. Following questions and comments from the Board, on MOTION by Reinhart, seconded by Withers, and unanimously carried, THE BOARD AUTHORIZED THE GENERAL MANAGER TO EXECUTE AN AGREEMENT WITH METROPOLITAN WATER DISTRICT OF SOUTHERN CALIFORNIA FOR LOCAL RESOURCE PROGRAM FUNDING FOR THE SYPHON

ACTION CALENDAR (CONTINUED)

RESERVOIR IMPROVEMENT PROJECT BASED ON THE ATTACHED TEMPLATE, SUBJECT TO NON-SUBSTANTIVE CHANGES.

14. SPECIAL ACTIVITIES AGREEMENTS FOR KERN FAN PROJECT

Director of Water Resources Nye presented two proposed Draft Special Activities Agreements for the South Enns and Rosedale 1 Channel components of the Kern Fan Project. She outlined the components and the draft provisions of the agreements.

Director Ferons reported that the item was reviewed at the Supply Reliability Programs Committee, and that the committee supported the staff recommendation. He further added that it was approved by the Groundwater Banking Joint Powers Authority earlier on April 27, 2026, and that it will be reviewed by the Rosedale-Rio Bravo Water Storage District on April 28, 2026. On MOTION by Ferons, seconded by Reinhart, and unanimously carried THE BOARD AUTHORIZED THE GENERAL MANAGER TO EXECUTE THE SPECIAL ACTIVITIES AGREEMENTS FOR THE SOUTH ENNS AND ROSEDALE 1 CHANNEL COMPONENTS OF THE KERN FAN PROJECT, BASED ON THE TERMS PRESENTED, SUBJECT TO NON-SUBSTANTIVE CHANGES.

15. REVISED WATER BANKING, TRANSFERS, AND WHEELING POLICY POSITION PAPER

Executive Director of Water Policy Weghorst proposed revisions to the District's Water Banking, Transfers, and Wheeling Policy Position Paper. The previous version was adopted by the Board in 2020 and since its approval, IRWD has completed its 2025 Water Supply Reliability Study; initiated construction on the Kern Fan Project; and participated in the planning and environmental review of the Sites Reservoir Project. Following feedback and comments from the Board, the recommendation was amended to include that the paper would be subject to non-substantive changes.

On MOTION by Withers, seconded by Reinhart, and unanimously carried, THE BOARD APPROVED THE UPDATED WATER BANKING, TRANSFERS, AND WHEELING POLICY POSITION PAPER SUBJECT TO NON-SUBSTANTIVE CHANGES.

OTHER BUSINESS

GENERAL MANAGER'S REPORT

General Manager Cook reported that the last meeting of the San Joaquin Wildlife Sanctuary Board was held last week. Pending the filing of taxes and payment of professional services, the remaining balance of the of the Sanctuary's cash will benefit the Sea & Sage Audubon Society.

RECEIVE ORAL UPDATE(S) FROM DISTRICT LIAISON(S) REGARDING COMMUNITIES WITHIN IRWD'S SERVICE AREA AND INTERESTS.

No report.

DIRECTORS' COMMENTS AND MEETING REPORTS

Director Withers reported on his attendance at the 2026 City of Irvine's State of the City presented by Mayor Larry Agran; and the Special San Joaquin Marsh Community Tour.

OTHER BUSINESS (CONTINUED)

Director Reinhart reported on his participation in the MWDOC Board of Directors' Meeting via teleconference; the OCWD Board of Directors' Meeting via teleconference; the UCI Baseball First Pitch featuring IRWD; and a meeting with District staff.

Vice President Ferons reported on his participation in the San Joaquin Wildlife Sanctuary Board meeting, he thanked the staff for their work on the SJWS Board and looks forward to working with Sea & Sage.

President LaMar reported on his participation in the CCEEB Board of Directors meeting and annual reception in Sacramento; the ACWA Executive Director recruitment meetings; the San Joaquin Wildlife Sanctuary Board meeting; the ACWA Vision Webinar via teleconference; the Natural Communities Coalition Executive Committee meeting; and the ACWA Headwaters Workgroup via teleconference.

ADJOURNMENT

At 6:40 p.m., President LaMar adjourned the Board meeting.

APPROVED and SIGNED this 26<sup>th</sup> day of May 2026.

---

President, IRVINE RANCH WATER DISTRICT

---

District Secretary,  
IRVINE RANCH WATER DISTRICT

APPROVED AS TO FORM:

---

Claire Hervey Collins, General Counsel  
Hanson Bridgett LLP

Note: This page is intentionally left blank.

## Attachment "A"

### My comments on Agenda Item 12 - April 27, 2026 Syphon Reservoir Award final

IRWD is currently projected to spend over \$2 billion dollars in capital improvements, capital replacement, and capital refurbishment over the next ten to fifteen years most of which will be paid for from borrowed money either from the issuance of General Obligation Bonds (to the extent that remaining authorization remains) which will be repaid mainly through a combination of property taxes and developer connection fees or by the issuance of Revenue Bonds which will be repaid directly from user rates. Both issuances will require the repayment of Issuance fees to the underwriter along with legal fees to Bond Council and more importantly interest costs for the amount borrowed. I have requested numerous times over the last two years that the staff project the financial impact of this significant amount of capital improvements on individual homeowners and businesses and have yet to receive a satisfactory response. As a consequence, I believe we should quickly complete this study and carefully analyze each large capital expenditure as to the need and priority prior to awarding construction. I believe that the construction of an enlarged Syphon Reservoir is not a necessary project and that the over \$330 million total project cost will be an unnecessary burden to place on the tax and rate payors in the district. I will give a quick summary of my understanding of the project, the reasons why I believe it is not needed, and a far less expensive alternative to address staff concerns.

#### History

Recycled water in the district is produced at a fairly constant rate every month while the demand for it changes dramatically based on the different seasons of the year (Demand exceeds monthly created supply during the hotter summer months and decreases during the cooler winter months – dramatically so during especially wet months). To maximize Recycled Water sales, one needs to store the excess production during cooler and wetter months for use during the months when demand exceeds production if that can be done in a cost-effective manner. The existing Syphon Reservoir was purchased at a time when it was estimated that this could be done at an all in cost of about \$76 million (a similar amount to the expected cost the Santa Margarita Water District's new reservoir of about the same size). The resulting increase in recycled sales along with other benefits appeared to justify the project at that time.

The total project cost over time has now quadrupled to the current projected cost of \$330 million. Increased focus on conservation of water has reduced supply, and some of the other benefits have been decreased. In short there is now no cost justification for this large expenditure. The principal OTHER benefit of the project was to avoid having to purchase and to maintain capacity at the Orange County Sanitation District (OCSD) for the disposal of recycled

water produced during winter and wetter months that exceeded existing storage and demand. With this saving it was estimated that the payback was at least 30 years after construction assuming a 4% cost of money. The assumptions here are that by taking savings to repay the debt that after at least 30 years our customers and taxpayers would be whole, that the costs at OCSD would continue to be high, that recycled water would not increase as much as projected as a result of the State wide focus on conservation; and the frequency of projected use of the added storage ( currently about one year every five) does not increase as currently projected.

Two things have changed. The first change resulted from a court case where IRWD's allowed pumping from the OC Groundwater Basin was limited to the Basin Production Percentage Times Total water use in IRWD within the boundary of the Orange County Water District (OCWD) less recycled water sales within the same area. The effect of this settlement reduced the amount of Groundwater that could be legally produced as future recycled sales increased due to increased winter storage. The less expensive groundwater would be mostly offset by increased recycled water sales gained from increased winter storage. The second change was an agreement to continued access to OCWD's Green Acres Distribution system that provided IRWD the ability to transfer excess winter production to OCSD and to OCWD's Groundwater Replenishment System (GWRS) project. The effect was to offset some or all of the costs charged by OCSD that produced the 30+ year payback. Now costs have increased and savings have further decreased and there appears to be no cost justification for this expensive project.

The need for the project can be met by supplying OCSD with recycled water through the existing Green Acres Project distribution system and putting any excess flow into the existing OCWD GWRS headworks or discharging directly from Green Acres into the existing OCSD outfall. Since most of the OCSD cost is in the treatment prior to discharge and recycled water already meets discharge standards, OCSD costs to IRWD would be greatly reduced. A further benefit could result from reducing IRWD recycled sales within the OCWD boundaries which would result in the ability to increase production of lower cost Groundwater.

**I request that the award of the contracts be deferred until the projects needs can be better evaluated and the overall capital projects impacts on rate and taxpayers can be fully vetted by the Board of Directors.**

May 26, 2026

Prepared by: B. Powell / J. Davis

Submitted by: N. Adly

Approved by: Paul A. Cook 

## CONSENT CALENDAR

### APRIL 2026 TREASURY REPORT

#### SUMMARY:

The following is submitted for the Board's information and approval:

- A. The April 2026 Investment Summary Report. This Investment Summary Report conforms with the 2026 Investment Policy as outlined in Exhibit "A";
- B. The Summary of Fixed and Variable Rate Debt as of April 30, 2026, as outlined in Exhibit "B";
- C. The Monthly Interest Rate Swap Summary as of April 30, 2026, as outlined in Exhibit "C";
- D. The April 30, 2026, Disbursement Summary of warrants 454518 through 455102, Workers' Compensation distributions, ACH payments, wire transfers, payroll withholding distributions, and voided checks in the net total amount of \$21,900,467 as outlined in Exhibit "D";
- E. The Summary of Payroll ACH payments in the total amount of \$2,898,781 as outlined in Exhibit "E"; and
- F. The Disclosure Report of Reimbursements to Board members and staff for April 2026, detailing payments or reimbursements for individual charges of \$100 or more per transaction as outlined in Exhibit "F".

#### FISCAL IMPACTS:

As of April 30, 2026, the book value of the investment portfolio was \$405,760,597, with a 3.93% rate of return and a market value of \$405,071,119.

As of April 30, 2026, the outstanding principal amount of fixed and variable rate debt was \$538,310,000. The monthly weighted average all-in variable rate was 2.96%. Including IRWD's weighted average fixed rate bond issues of 3.03% and the negative cash accruals from fixed payer interest rate swaps, which hedge a portion of the District's variable rate debt, the total average debt rate was 3.18%.

Payroll ACH payments totaled \$2,898,781. Wire transfers, other ACH payments, and checks issued for debt service, accounts payable, payroll, water purchases, and voided checks for April were \$21,900,467.

#### ENVIRONMENTAL COMPLIANCE:

This item is not a project as defined in the California Environmental Quality Act Code of Regulations, Title 14, Chapter 3, Section 15378.

COMMITTEE STATUS:

All items in this report were not submitted to a Committee; the investment and debt reports are submitted to the Finance and Personnel Committee monthly.

RECOMMENDATION:

THAT THE BOARD RECEIVE AND FILE THE TREASURER'S INVESTMENT SUMMARY REPORT, THE SUMMARY OF FIXED AND VARIABLE RATE DEBT, AND THE DISCLOSURE REPORT OF REIMBURSEMENTS TO BOARD MEMBERS AND STAFF, APPROVE THE APRIL 2026 SUMMARY OF PAYROLL ACH PAYMENTS IN THE TOTAL AMOUNT OF \$2,898,781 AND APPROVE THE APRIL 2026 ACCOUNTS PAYABLE DISBURSEMENT SUMMARY OF WARRANTS 454518 THROUGH 455102, WORKERS' COMPENSATION DISTRIBUTIONS, ACH PAYMENTS, WIRE TRANSFERS, PAYROLL WITHHOLDING DISTRIBUTIONS, AND VOIDED CHECKS IN THE NET TOTAL AMOUNT OF \$21,900,467.

LIST OF EXHIBITS:

Exhibit "A" – Investment Summary Report

Exhibit "B" – Summary of Fixed and Variable Rate Debt

Exhibit "C" – Monthly Interest Rate Swap Summary

Exhibit "D" – Monthly Summary of District Disbursements

Exhibit "E" – Monthly Payroll ACH Summary

Exhibit "F" – Disclosure of Reimbursements to Board Members and Staff



Dashboard

04/01/2026 - 04/30/2026

Irvine Ranch Water District (491783)

Dated: 05/05/2026

Portfolio Summary		
	<i>Irvine Ranch Water District</i>	<i>Grand Total</i>
Par Value	408,380,310.83	408,380,310.83
Principal Cost	405,760,597.08	405,760,597.08
Book Value	405,760,597.08	405,760,597.08
Market Value	405,071,119.05	405,071,119.05
Unrealized Gain/Loss	-689,478.04	-689,478.04
Accrued Interest	2,230,511.72	2,230,511.72

Footnotes: 1,2,3

Portfolio Characteristics		
	<i>Irvine Ranch Water District</i>	<i>Grand Total</i>
Weighted Average Maturity	2.234	2.234
Portfolio Effective Duration	1.902	1.902
Weighted Average Life	2.048	2.048
Average Credit Rating	AA-	AA-
Yield at Cost	3.93	3.93

Footnotes: 1,2,3

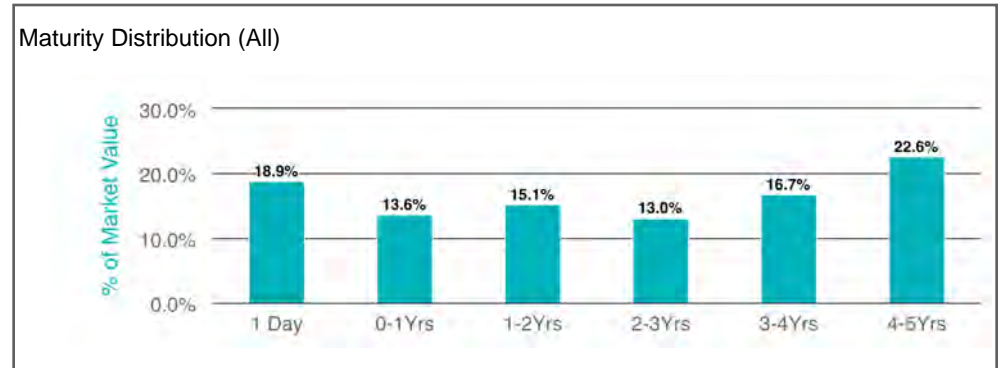
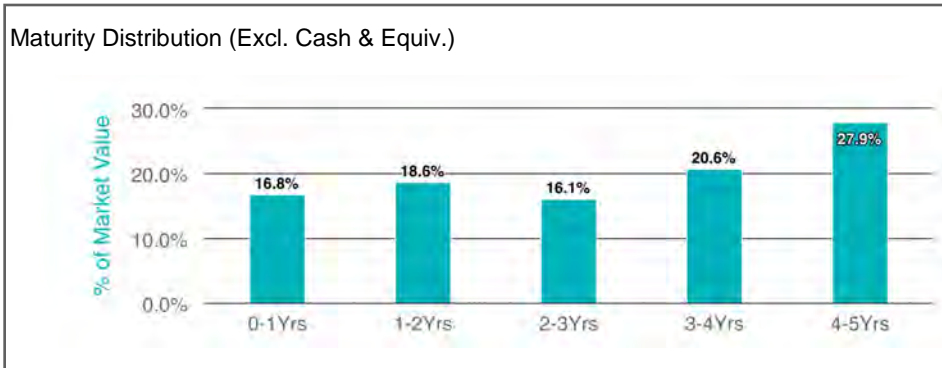



Dashboard

04/01/2026 - 04/30/2026

Irvine Ranch Water District (491783)

Dated: 05/05/2026

Asset Allocation

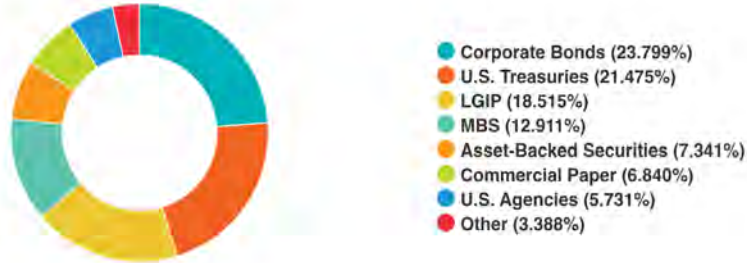

Chart calculated by: % of Market Value

Credit Quality



Chart calculated by: % of Market Value

Issuer Concentration

Issuer Concentration	Ending Current Units	Ending Book Value	% of Ending Book Value
Other*	157,127,152.37	156,228,883.80	38.502%
United States	92,500,000.00	91,333,977.36	22.509%
(CALAIF) California LAIF	74,999,807.18	74,999,807.18	18.484%
Federal National Mortgage Association	31,144,380.81	30,540,370.79	7.527%
Federal Home Loan Mortgage Corporation	24,214,192.15	24,013,227.56	5.918%
New York Life Insurance Company	16,900,000.00	17,061,113.00	4.205%
Citigroup Inc.	11,500,000.00	11,588,439.06	2.856%

<b>Total**</b>	<b>408,385,532.50</b>	<b>405,765,818.75</b>	<b>100.000%</b>
----------------	-----------------------	-----------------------	-----------------

\*Other is the total of individual issuer concentrations below 2.0%

\*\* Total includes receivable \$5,221.67 not reflected in portfolio summary

# Position Statement

CUSIP	DESCRIPTION	TRADE DATE SETTLE DATE	PAR VALUE	PRINCIPAL COST PURCHASED INTEREST	TOTAL COST	YIELD TO MATURITY	MATURITY DATE	DAYS TO MATURITY	MARKET PRICE MARKET VALUE	UNREALIZED GAIN/LOSS BOOK VALUE	% OF MV	MOODY'S S&P RATING
<b>IRVINE RANCH WATER DISTRICT</b>												
<b>LGIP</b>												
CALAIF	California LAIF	04/30/2026 04/30/2026	74,999,807.18	74,999,807.18 0.00	74,999,807.18	3.81		1	1.00 74,999,807.18	0.00 74,999,807.18	18.52	NA
<b>LGIP TOTAL</b>			<b>74,999,807.18</b>	<b>74,999,807.18 0.00</b>	<b>74,999,807.18</b>	<b>3.81</b>		<b>1</b>	<b>1.00 74,999,807.18</b>	<b>0.00 74,999,807.18</b>	<b>18.52</b>	<b>NA</b>
<b>MONEY MARKET FUNDS</b>												
262006307	DREYFUS GVT CM;INV	04/30/2026 04/30/2026	1,359,333.53	1,359,333.53 0.00	1,359,333.53	3.29		1	1.00 1,359,333.53	0.00 1,359,333.53	0.34	Aaa AAA
<b>MONEY MARKET FUNDS TOTAL</b>			<b>1,359,333.53</b>	<b>1,359,333.53 0.00</b>	<b>1,359,333.53</b>	<b>3.29</b>		<b>1</b>	<b>1.00 1,359,333.53</b>	<b>0.00 1,359,333.53</b>	<b>0.34</b>	<b>AAA</b>
<b>COMMERCIAL PAPER</b>												
06741EES5	BARCLAYS BNK PLC 05/26/26	01/13/2026 01/14/2026	5,000,000.00	4,931,433.34 0.00	4,931,433.34	3.79	05/26/2026	26	99.74 4,987,013.89	55,580.55 4,931,433.34	1.23	P-1 A-1+
53944RF52	LMA 06/05/26	01/08/2026 01/09/2026	5,000,000.00	4,923,845.83 0.00	4,923,845.83	3.79	06/05/2026	36	99.64 4,981,868.05	58,022.22 4,923,845.83	1.23	P-1 A-1
55458FGA9	MACKINAC FUNDING 07/10/26	01/08/2026 01/09/2026	5,000,000.00	4,905,208.33 0.00	4,905,208.33	3.82	07/10/2026	71	99.27 4,963,541.67	58,333.34 4,905,208.33	1.23	P-1 A-1
21687BJ10	COOPERATIVE UA 09/01/26	01/06/2026 01/07/2026	5,000,000.00	4,880,183.33 0.00	4,880,183.33	3.73	09/01/2026	124	98.76 4,937,816.66	57,633.33 4,880,183.33	1.22	P-1 A-1
53948BLH0	LLOYDS BK NY BR 11/17/26	02/23/2026 02/23/2026	8,000,000.00	7,782,840.00 0.00	7,782,840.00	3.76	11/17/2026	201	97.97 7,837,333.33	54,493.33 7,782,840.00	1.93	P-1 A-1
<b>COMMERCIAL PAPER TOTAL</b>			<b>28,000,000.00</b>	<b>27,423,510.83 0.00</b>	<b>27,423,510.83</b>	<b>3.78</b>		<b>103</b>	<b>98.96 27,707,573.61</b>	<b>284,062.78 27,423,510.83</b>	<b>6.84</b>	<b>A+</b>
<b>U.S. TREASURIES</b>												
91282CKV2	US TREASURY 4.625 06/15/27	02/05/2025 02/05/2025	5,000,000.00	5,044,921.88 0.00	5,044,921.88	4.22	06/15/2027	411	100.89 5,044,531.25	(390.63) 5,044,921.88	1.25	Aa1 AA+
91282CKZ3	US TREASURY 4.375 07/15/27	11/08/2024 11/08/2024	5,000,000.00	5,027,343.75 0.00	5,027,343.75	4.16	07/15/2027	441	100.63 5,031,445.30	4,101.55 5,027,343.75	1.24	Aa1 AA+
91282CFH9	US TREASURY 3.125 08/31/27	01/09/2025 01/09/2025	5,000,000.00	4,854,687.50 0.00	4,854,687.50	4.30	08/31/2027	488	99.05 4,952,734.40	98,046.90 4,854,687.50	1.22	Aa1 AA+
91282CFM8	US TREASURY 4.125 09/30/27	03/11/2024 03/11/2024	5,000,000.00	4,988,476.57 0.00	4,988,476.57	4.19	09/30/2027	518	100.35 5,017,382.80	28,906.24 4,988,476.57	1.24	Aa1 AA+
9128283W8	US TREASURY 2.750 02/15/28	12/19/2024 12/19/2024	5,000,000.00	4,783,593.75 0.00	4,783,593.75	4.23	02/15/2028	656	98.04 4,901,953.15	118,359.40 4,783,593.75	1.21	Aa1 AA+
91282CBZ3	US TREASURY 1.250 04/30/28	07/18/2024 07/18/2024	5,000,000.00	4,496,484.38 0.00	4,496,484.38	4.15	04/30/2028	731	94.96 4,748,242.20	251,757.82 4,496,484.38	1.17	Aa1 AA+
91282CHQ7	US TREASURY 4.125 07/31/28	06/27/2024 06/27/2024	10,000,000.00	9,900,000.00 0.00	9,900,000.00	4.39	07/31/2028	823	100.49 10,049,218.80	149,218.80 9,900,000.00	2.48	Aa1 AA+
9128284V9	US TREASURY 2.875 08/15/28	08/16/2024 08/16/2024	5,000,000.00	4,820,312.50 0.00	4,820,312.50	3.85	08/15/2028	838	97.77 4,888,671.90	68,359.40 4,820,312.50	1.21	Aa1 AA+

## Position Statement

CUSIP	DESCRIPTION	TRADE DATE SETTLE DATE	PAR VALUE	PRINCIPAL COST PURCHASED INTEREST	TOTAL COST	YIELD TO MATURITY	MATURITY DATE	DAYS TO MATURITY	MARKET PRICE MARKET VALUE	UNREALIZED GAIN/LOSS BOOK VALUE	% OF MV	MOODY'S S&P RATING
91282CJW2	US TREASURY 4.000 01/31/29	04/16/2025 04/17/2025	5,000,000.00	5,025,585.94 0.00	5,025,585.94	3.85	01/31/2029	1,007	100.23 5,011,328.15	(14,257.79) 5,025,585.94	1.24	Aa1 AA+
9128286B1	US TREASURY 2.625 02/15/29	04/16/2025 04/17/2025	5,000,000.00	4,783,398.44 0.00	4,783,398.44	3.85	02/15/2029	1,022	96.62 4,830,859.40	47,460.96 4,783,398.44	1.19	Aa1 AA+
91282CFT3	US TREASURY 4.000 10/31/29	06/13/2025 06/16/2025	5,000,000.00	4,997,656.25 0.00	4,997,656.25	4.01	10/31/2029	1,280	100.16 5,007,812.50	10,156.25 4,997,656.25	1.24	Aa1 AA+
91282CMA6	US TREASURY 4.125 11/30/29	06/05/2025 06/06/2025	5,000,000.00	5,031,250.00 0.00	5,031,250.00	3.97	11/30/2029	1,310	100.56 5,028,125.00	(3,125.00) 5,031,250.00	1.24	Aa1 AA+
91282CGQ8	US TREASURY 4.000 02/28/30	06/05/2025 06/06/2025	5,000,000.00	5,004,687.50 0.00	5,004,687.50	3.98	02/28/2030	1,400	100.10 5,005,078.15	390.65 5,004,687.50	1.24	Aa1 AA+
91282CMU2	US TREASURY 4.000 03/31/30	06/05/2025 06/06/2025	5,000,000.00	5,002,148.44 0.00	5,002,148.44	3.99	03/31/2030	1,431	100.09 5,004,687.50	2,539.06 5,002,148.44	1.24	Aa1 AA+
91282CNK3	US TREASURY 3.875 06/30/30	06/26/2025 06/30/2025	7,500,000.00	7,519,628.91 0.00	7,519,628.91	3.82	06/30/2030	1,522	99.57 7,467,773.48	(51,855.44) 7,519,628.91	1.84	Aa1 AA+
91282CHR5	US TREASURY 4.000 07/31/30	09/23/2025 09/24/2025	5,000,000.00	5,069,726.56 0.00	5,069,726.56	3.68	07/31/2030	1,553	100.02 5,000,781.25	(68,945.31) 5,069,726.56	1.23	Aa1 AA+
<b>U.S. TREASURIES TOTAL</b>			<b>87,500,000.00</b>	<b>86,349,902.37 0.00</b>	<b>86,349,902.37</b>	<b>4.06</b>		<b>973</b>	<b>99.44 86,990,625.23</b>	<b>640,722.86 86,349,902.37</b>	<b>21.48</b>	<b>AA+</b>
<b>U.S. AGENCIES</b>												
74274TAL4	PEFCO 4.500 02/07/27 MTN	01/07/2026 01/08/2026	6,500,000.00	6,553,209.00 0.00	6,553,209.00	3.72	02/07/2027	283	100.10 6,506,760.00	(46,449.00) 6,553,209.00	1.61	Aa2 NA
742651EA6	PEFCO 4.300 12/15/28	01/07/2026 01/08/2026	5,000,000.00	5,100,100.00 13,736.11	5,113,836.11	3.57	12/15/2028	960	100.53 5,026,550.00	(73,550.00) 5,100,100.00	1.24	Aa1 NA
3133ER6D8	FED FARM CR BNKS 4.000 03/07/29	04/16/2025 04/17/2025	5,000,000.00	5,022,850.00 0.00	5,022,850.00	3.87	03/07/2029	1,042	100.09 5,004,350.00	(18,500.00) 5,022,850.00	1.24	Aa1 AA+
880591FE7	TVA 3.875 08/01/30	08/08/2025 08/11/2025	5,000,000.00	4,984,075.00 0.00	4,984,075.00	3.95	08/01/2030	1,554	99.25 4,962,400.00	(21,675.00) 4,984,075.00	1.23	Aa1 AA+
3136GCG90	FANNIE MAE 3.875 01/27/31'28	01/14/2026 01/27/2026	1,750,000.00	1,750,000.00 0.00	1,750,000.00	3.88	01/27/2031	1,733	98.03 1,715,595.00	(34,405.00) 1,750,000.00	0.42	Aa1 AA+
<b>U.S. AGENCIES TOTAL</b>			<b>23,250,000.00</b>	<b>23,410,234.00 13,736.11</b>	<b>23,423,970.11</b>	<b>3.78</b>		<b>972</b>	<b>99.86 23,215,655.00</b>	<b>(194,579.00) 23,410,234.00</b>	<b>5.73</b>	<b>AA+</b>
<b>MBS</b>												
3140LJV52	FNBS7835	01/06/2026 01/09/2026	3,646,380.81	3,675,295.47 0.00	3,675,295.47	3.94	03/01/2028	671	99.70 3,635,355.72	(39,939.75) 3,675,295.47	0.90	Aa1 AA+
3137FKUP9	FH-K087-A2	01/07/2026 01/12/2026	130,545.11	130,208.55 0.00	130,208.55	3.77	12/25/2028	970	98.87 129,076.31	(1,322.24) 130,208.55	0.03	Aa1 AAA
3137FKUP9	FH-K087-A2	01/06/2026 01/09/2026	4,177,443.59	4,170,590.00 0.00	4,170,590.00	3.74	12/25/2028	970	98.87 4,130,441.96	(40,148.05) 4,170,590.00	1.02	Aa1 AAA
3137FMCR1	FH-K093-A2	01/12/2026 01/15/2026	4,906,203.45	4,784,889.94 0.00	4,784,889.94	3.70	05/25/2029	1,121	96.67 4,742,838.80	(42,051.14) 4,784,889.94	1.17	Aa1 AA+
3137FNX54	FH-K097-A2	01/12/2026 01/15/2026	5,000,000.00	4,780,078.13 0.00	4,780,078.13	3.79	07/25/2029	1,182	94.89 4,744,319.20	(35,758.93) 4,780,078.13	1.17	Aaa AA+
3132KXKL6	FH WN5182	01/06/2026 01/09/2026	5,000,000.00	5,065,039.06 0.00	5,065,039.06	4.22	12/01/2029	1,311	100.53 5,026,571.45	(38,467.61) 5,065,039.06	1.24	Aa1 AA+

## Position Statement

CUSIP	DESCRIPTION	TRADE DATE SETTLE DATE	PAR VALUE	PRINCIPAL COST PURCHASED INTEREST	TOTAL COST	YIELD TO MATURITY	MATURITY DATE	DAYS TO MATURITY	MARKET PRICE MARKET VALUE	UNREALIZED GAIN/LOSS BOOK VALUE	% OF MV	MOODY'S S&P RATING
3137HKXJ8	FH-K539-A2	01/07/2026 01/12/2026	5,000,000.00	5,082,421.88 0.00	5,082,421.88	3.89	01/25/2030	1,366	100.36 5,018,070.70	(64,351.18) 5,082,421.88	1.24	Aa1 AA+
3140Q0CX8	FN BZ4585	01/06/2026 01/09/2026	2,588,000.00	2,599,221.41 0.00	2,599,221.41	4.00	08/01/2030	1,554	99.45 2,573,884.40	(25,337.01) 2,599,221.41	0.64	Aa1 AA+
3140Q0KP6	FN BZ4801	01/13/2026 01/16/2026	6,410,000.00	6,459,076.56 0.00	6,459,076.56	4.04	09/01/2030	1,585	99.56 6,382,048.55	(77,028.01) 6,459,076.56	1.58	Aa1 AA+
3140Q06A5	FN BZ5364	01/09/2026 01/14/2026	5,250,000.00	5,236,464.84 0.00	5,236,464.84	4.03	11/01/2030	1,646	98.60 5,176,596.08	(59,868.77) 5,236,464.84	1.28	Aa1 AA+
3140JBFJ0	FN BM6468 1.429 11/01/2030	01/06/2026 01/09/2026	5,500,000.00	4,868,359.38 0.00	4,868,359.38	4.00	11/01/2030	1,646	88.17 4,849,509.61	(18,849.77) 4,868,359.38	1.20	Aa1 AA+
3140Q2C97	FN BZ6395	02/06/2026 02/18/2026	6,000,000.00	5,951,953.13 0.00	5,951,953.13	4.01	02/01/2031	1,738	98.14 5,888,694.18	(63,258.95) 5,951,953.13	1.45	Aa1 AA+
<b>MBS TOTAL</b>			<b>53,608,572.95</b>	<b>52,803,598.34 0.00</b>	<b>52,803,598.34</b>	<b>3.95</b>		<b>1,373</b>	<b>97.68 52,297,406.95</b>	<b>(506,191.39) 52,803,598.34</b>	<b>12.91</b>	<b>AA+</b>
<b>MUNICIPAL BONDS</b>												
923078CW7	VENTURA CNTY CALIF PUB FING 1.541 11/01/26	01/08/2026 01/09/2026	3,000,000.00	2,946,540.00 8,732.33	2,955,272.33	3.79	11/01/2026	185	98.91 2,967,186.00	20,646.00 2,946,540.00	0.73	Aa1 AA+
68609TWF1	OREGON 1.315 05/01/27	01/07/2026 01/08/2026	2,395,000.00	2,323,341.60 5,861.43	2,329,203.03	3.67	05/01/2027	366	97.47 2,334,497.51	11,155.91 2,323,341.60	0.58	Aa1 AA+
446201AF2	HUNTINGTON BEACH CALIF PENS 1.681 06/15/27	01/06/2026 01/07/2026	2,100,000.00	2,040,360.00 2,157.28	2,042,517.28	3.73	06/15/2027	411	97.46 2,046,678.90	6,318.90 2,040,360.00	0.51	NA AA+
923078CY3	VENTURA CNTY CALIF PUB FING 1.962 11/01/28	01/07/2026 01/08/2026	4,000,000.00	3,806,760.00 14,606.00	3,821,366.00	3.79	11/01/2028	916	95.02 3,800,628.00	(6,132.00) 3,806,760.00	0.94	Aa1 AA+
223093VT9	COVINA-VALLEY CALIF UNI SCH 2.490 08/01/30 '29	01/08/2026 01/09/2026	1,300,000.00	1,222,039.00 0.00	1,222,039.00	3.94	08/01/2030	1,554	93.14 1,210,822.60	(11,216.40) 1,222,039.00	0.30	NA AA
<b>MUNICIPAL BONDS TOTAL</b>			<b>12,795,000.00</b>	<b>12,339,040.60 31,357.04</b>	<b>12,370,397.64</b>	<b>3.77</b>		<b>616</b>	<b>96.64 12,359,813.01</b>	<b>20,772.41 12,339,040.60</b>	<b>3.05</b>	<b>AA+</b>
<b>ASSET-BACKED SECURITIES</b>												
16144YAC2	CAOT-244-A3	01/13/2026 01/14/2026	3,650,761.80	3,687,697.25 0.00	3,687,697.25	3.85	07/25/2029	1,182	100.59 3,672,280.74	(15,416.51) 3,687,697.25	0.91	NA AAA
16144QAC9	CAOT-245-A3	02/05/2026 02/06/2026	4,666,835.37	4,682,877.61 0.00	4,682,877.61	3.84	08/27/2029	1,215	100.06 4,669,505.78	(13,371.84) 4,682,877.61	1.15	NA AAA
14041NGE5	COMET-241-A	01/12/2026 01/13/2026	5,000,000.00	5,012,500.00 0.00	5,012,500.00	3.77	09/17/2029	1,236	99.82 4,990,886.25	(21,613.75) 5,012,500.00	1.23	NA AAA
17305EGS8	CCCIT-18A7-A7	01/12/2026 01/13/2026	6,500,000.00	6,518,789.06 0.00	6,518,789.06	3.85	10/15/2030	1,629	99.42 6,462,546.87	(56,242.19) 6,518,789.06	1.60	Aaa AAA
14320HAD8	CARMAX-254-A3	01/12/2026 01/13/2026	5,000,000.00	5,011,132.81 0.00	5,011,132.81	3.91	12/16/2030	1,691	99.16 4,957,988.90	(53,143.91) 5,011,132.81	1.22	NA AAA
92970QAK1	WFCIT-261-A	04/21/2026 04/27/2026	5,000,000.00	4,999,299.00 0.00	4,999,299.00	4.08	04/15/2031	1,811	99.69 4,984,346.00	(14,953.00) 4,999,299.00	1.23	Aaa NA
<b>ASSET-BACKED SECURITIES TOTAL</b>			<b>29,817,597.17</b>	<b>29,912,295.73 0.00</b>	<b>29,912,295.73</b>	<b>3.88</b>		<b>1,484</b>	<b>99.73 29,737,554.54</b>	<b>(174,741.19) 29,912,295.73</b>	<b>7.34</b>	<b>AAA</b>

## Position Statement

CUSIP	DESCRIPTION	TRADE DATE SETTLE DATE	PAR VALUE	PRINCIPAL COST PURCHASED INTEREST	TOTAL COST	YIELD TO MATURITY	MATURITY DATE	DAYS TO MATURITY	MARKET PRICE MARKET VALUE	UNREALIZED GAIN/LOSS BOOK VALUE	% OF MV	MOODY'S S&P RATING
<b>CORPORATE BONDS</b>												
46625HRV4	JP MORGAN 2.950 10/01/26 '26	01/13/2026 01/14/2026	3,000,000.00	2,982,990.00 0.00	2,982,990.00	3.76	10/01/2026	154	99.59 2,987,700.00	4,710.00 2,982,990.00	0.74	A1 A
17325FBC1	CITIBANK NA US 5.488 12/04/26 '26	01/06/2026 01/07/2026	5,000,000.00	5,069,650.00 25,153.33	5,094,803.33	3.75	12/04/2026	218	100.69 5,034,350.00	(35,300.00) 5,069,650.00	1.24	Aa3 A+
06055JPX1	BOFAML 3.860 03/23/27 '26 MTN	01/06/2026 01/23/2026	5,000,000.00	5,000,000.00 0.00	5,000,000.00	3.86	03/23/2027	327	99.22 4,960,850.00	(39,150.00) 5,000,000.00	1.22	A1 A-
64952WEQ2	NYL GLOBAL FUND 3.250 04/07/27 MTN	01/06/2026 01/07/2026	5,000,000.00	4,972,150.00 0.00	4,972,150.00	3.71	04/07/2027	342	99.32 4,966,200.00	(5,950.00) 4,972,150.00	1.23	Aa1 AA+
857477CP6	STATE STREET 4.330 10/22/27 '27	01/08/2026 01/09/2026	5,000,000.00	5,050,750.00 0.00	5,050,750.00	3.71	10/22/2027	540	100.25 5,012,450.00	(38,300.00) 5,050,750.00	1.24	Aa3 A
64952WFL2	NYL GLOBAL FUND 4.400 12/13/27 MTN	01/12/2026 01/13/2026	3,000,000.00	3,028,860.00 11,000.00	3,039,860.00	3.87	12/13/2027	592	100.04 3,001,140.00	(27,720.00) 3,028,860.00	0.74	Aa1 AA+
64952WEY5	NYL GLOBAL FUND 4.850 01/09/28 MTN	01/09/2026 01/12/2026	3,000,000.00	3,055,260.00 1,212.50	3,056,472.50	3.88	01/09/2028	619	100.95 3,028,410.00	(26,850.00) 3,055,260.00	0.75	Aa1 AA+
14913UBF6	CTRPLLR FIN SERV 3.700 01/10/28 MTN	01/06/2026 01/08/2026	5,000,000.00	4,998,250.00 0.00	4,998,250.00	3.72	01/10/2028	620	99.44 4,972,050.00	(26,200.00) 4,998,250.00	1.23	A1 A
66815L2V0	NORTHWESTERN MUT 4.490 03/21/28 MTN	01/13/2026 01/14/2026	5,000,000.00	5,059,750.00 0.00	5,059,750.00	3.91	03/21/2028	691	100.32 5,015,750.00	(44,000.00) 5,059,750.00	1.24	Aa1 AA+
6944PL2S7	PACIFIC LIFE GLO 4.900 04/04/28 MTN	01/09/2026 01/12/2026	2,450,000.00	2,498,485.50 0.00	2,498,485.50	3.96	04/04/2028	705	100.88 2,471,511.00	(26,974.50) 2,498,485.50	0.61	Aa3 AA-
806851AK7	SCHLUMBERGER HLD 3.900 05/17/28 '28	04/29/2026 04/30/2026	5,000,000.00	4,965,650.00 88,291.67	5,053,941.67	4.25	05/17/2028	748	99.26 4,962,750.00	(2,900.00) 4,965,650.00	1.23	A3 A
713448GL6	PEPSICO 4.100 01/15/29 '28	01/07/2026 01/08/2026	5,000,000.00	5,038,350.00 0.00	5,038,350.00	3.82	01/15/2029	991	99.92 4,995,900.00	(42,450.00) 5,038,350.00	1.23	A1 A+
59217GDC0	METLIFE GBL FDG 3.050 06/17/29 MTN	01/06/2026 01/07/2026	1,000,000.00	966,290.00 1,694.44	967,984.44	4.11	06/17/2029	1,144	95.80 958,040.00	(8,250.00) 966,290.00	0.24	Aa3 AA-
89236TKD6	TOYOTA MOTOR CRD 4.450 06/29/29 MTN	01/06/2026 01/07/2026	3,000,000.00	3,046,320.00 2,966.67	3,049,286.67	3.97	06/29/2029	1,156	100.30 3,009,060.00	(37,260.00) 3,046,320.00	0.74	A1 A+
532457CQ9	LILLY 4.200 08/14/29 '29	01/12/2026 01/13/2026	5,000,000.00	5,049,950.00 0.00	5,049,950.00	3.89	08/14/2029	1,202	99.88 4,994,100.00	(55,850.00) 5,049,950.00	1.23	Aa3 AA-
64952WFK4	NYL GLOBAL FUND 4.600 12/05/29 MTN	01/08/2026 01/09/2026	5,900,000.00	6,004,843.00 25,632.22	6,030,475.22	4.10	12/05/2029	1,315	100.57 5,933,335.00	(71,508.00) 6,004,843.00	1.46	Aa1 AA+
166764BY5	CHEVRON 2.236 05/11/30 '30	01/06/2026 01/07/2026	6,000,000.00	5,572,080.00 20,869.33	5,592,949.33	4.04	05/11/2030	1,472	92.41 5,544,780.00	(27,300.00) 5,572,080.00	1.37	Aa2 AA-
24422EYF0	JOHN DEERE CAP 4.375 10/15/30 MTN	01/08/2026 01/09/2026	5,000,000.00	5,057,600.00 0.00	5,057,600.00	4.11	10/15/2030	1,629	99.84 4,991,850.00	(65,750.00) 5,057,600.00	1.23	A1 A
30303MAB8	META PLATFORMS 4.200 11/15/30 '30	01/12/2026 01/13/2026	5,000,000.00	5,005,950.00 40,833.33	5,046,783.33	4.17	11/15/2030	1,660	98.80 4,940,000.00	(65,950.00) 5,005,950.00	1.22	Aa3 AA-
59217GFU8	METLIFE GBL FDG 4.350 01/12/31 MTN	01/06/2026 01/12/2026	5,000,000.00	5,001,100.00 0.00	5,001,100.00	4.35	01/12/2031	1,718	98.76 4,938,000.00	(63,100.00) 5,001,100.00	1.22	Aa3 AA-
66989HBG2	NOVARTIS CAP 4.400 03/18/31 '31	03/17/2026 03/18/2026	4,700,000.00	4,714,946.00 0.00	4,714,946.00	4.33	03/18/2031	1,783	99.84 4,692,574.00	(22,372.00) 4,714,946.00	1.16	Aa3 AA-
74368CCE2	PROTECTIVE 4.827 04/14/31 MTN	04/21/2026 04/22/2026	5,000,000.00	5,023,650.00 5,363.33	5,029,013.33	4.72	04/14/2031	1,810	99.85 4,992,550.00	(31,000.00) 5,023,650.00	1.23	A1 AA-

## Position Statement

CUSIP	DESCRIPTION	TRADE DATE SETTLE DATE	PAR VALUE	PRINCIPAL COST PURCHASED INTEREST	TOTAL COST	YIELD TO MATURITY	MATURITY DATE	DAYS TO MATURITY	MARKET PRICE MARKET VALUE	UNREALIZED GAIN/LOSS BOOK VALUE	% OF MV	MOODY'S S&P RATING
<b>CORPORATE BONDS TOTAL</b>			97,050,000.00	97,162,874.50 223,016.82	97,385,891.32	4.01		1,006	99.37 96,403,350.00	(759,524.50) 97,162,874.50	23.80	A+
<b>IRVINE RANCH WATER DISTRICT TOTAL</b>			408,380,310.83	405,760,597.08 268,109.97	406,028,707.05	3.93		816	405,071,119.05	(689,478.04) 405,760,597.08	100.00	AA-
<b>GRAND TOTAL</b>			408,380,310.83	405,760,597.08 268,109.97	406,028,707.05	3.93		816	405,071,119.05	(689,478.04) 405,760,597.08	100.00	AA-

# Transaction Statement

IRVINE RANCH WATER DISTRICT									
	TRADE DATE	SETTLE DATE	CUSIP	DESCRIPTION	PAR VALUE	PRINCIPAL COST	PURCHASED INTEREST	TOTAL	PURCHASE YIELD
<b>BUY</b>									
	04/21/2026	04/22/2026	74368CCE2	PROTECTIVE 4.827 04/14/31 MTN	5,000,000.00	5,023,650.00	5,363.33	(5,029,013.33)	4.72
	04/21/2026	04/27/2026	92970QAK1	WFCIT-261-A	5,000,000.00	4,999,299.00	0.00	(4,999,299.00)	4.08
	04/29/2026	04/30/2026	806851AK7	SCHLUMBERGER HLD 3.900 05/17/28 '28	5,000,000.00	4,965,650.00	88,291.67	(5,053,941.67)	4.25
<b>BUY TOTAL</b>					<b>15,000,000.00</b>	<b>14,988,599.00</b>	<b>93,655.00</b>	<b>(15,082,254.00)</b>	<b>4.35</b>
	TRADE DATE	SETTLE DATE	CUSIP	DESCRIPTION	PAR VALUE	BOOK VALUE	TOTAL	NET REALIZED GAIN/LOSS	
<b>MATURITY</b>									
	04/09/2026	04/09/2026	04208DD91	Armada Funding Company, LLC 0.0 04/09/2026	(5,000,000.00)	4,955,020.83	5,000,000.00	44,979.17	
<b>MATURITY TOTAL</b>					<b>(5,000,000.00)</b>	<b>4,955,020.83</b>	<b>5,000,000.00</b>	<b>44,979.17</b>	
	TRADE DATE	SETTLE DATE	CUSIP	DESCRIPTION	PAR VALUE	BOOK VALUE	TOTAL	NET REALIZED GAIN/LOSS	
<b>PRINCIPAL PAYDOWN</b>									
	04/27/2026	04/27/2026	16144YAC2	CAOT-244-A3	(279,539.17)	282,367.32	279,539.16	(2,828.16)	
	04/27/2026	04/27/2026	16144QAC9	CAOT-245-A3	(333,164.63)	334,309.89	333,164.63	(1,145.26)	
	04/27/2026	04/27/2026	3140LJV52	FN BS7835	(3,619.19)	3,647.89	3,619.19	(28.70)	
	04/27/2026	04/27/2026	3137FKUP9	FH-K087-A2	(4,877.65)	4,869.50	4,877.69	8.19	
	04/27/2026	04/27/2026	3137FMCR1	FH-K093-A2	(5,570.30)	5,432.57	5,570.30	137.73	
<b>PRINCIPAL PAYDOWN TOTAL</b>					<b>(626,770.94)</b>	<b>630,627.17</b>	<b>626,770.97</b>	<b>(3,856.20)</b>	
	TRADE DATE	SETTLE DATE	CUSIP	DESCRIPTION	PAR VALUE	BOOK VALUE	TOTAL	NET REALIZED GAIN/LOSS	
<b>SELL</b>									
	04/21/2026	04/22/2026	931142FN8	WALMART 4.350 04/28/30 '30	(5,000,000.00)	5,075,350.00	5,063,400.00	(11,950.00)	
	04/23/2026	04/24/2026	3133ER6D8	FED FARM CR BNKS 4.000 03/07/29	(5,000,000.00)	5,022,850.00	5,017,100.00	(5,750.00)	
	04/29/2026	04/30/2026	91282CCE9	US TREASURY 1.250 05/31/28	(5,000,000.00)	4,513,671.88	4,735,546.88	221,875.00	



## Transaction Statement

---

<b>SELL TOTAL</b>	<b>(15,000,000.00)</b>	<b>14,611,871.88</b>	<b>14,816,046.88</b>	<b>204,175.00</b>
-------------------	------------------------	----------------------	----------------------	-------------------

---



## Future Maturities

Irvine Ranch Water District (491783)

Base Currency: USD As of 04/30/2026

Dated: 05/14/2026

<i>Maturity Bands</i>	<i>Identifier</i>	<i>Security Description</i>	<i>Final Maturity</i>	<i>Asset Type</i>	<i>Base Current Units</i>	<i>Base Original Cost</i>	<i>Base Market Value + Accrued</i>
1 Month	---	---	05/02/2026	---	81,359,140.71	81,290,574.05	81,346,154.60
2 Months	53944RF52	LMA 06/05/26	06/05/2026	Commercial Paper	5,000,000.00	4,923,845.83	4,981,868.05
3 Months	55458FGA9	MACKINAC FUNDING 07/10/26	07/10/2026	Commercial Paper	5,000,000.00	4,905,208.33	4,963,541.67
6 Months	---	---	09/12/2026	---	8,000,000.00	7,863,173.33	7,932,891.66
9 Months	---	---	11/19/2026	---	16,000,000.00	15,799,030.00	15,974,031.00
12 Months	---	---	03/10/2027	---	16,500,000.00	16,525,359.00	16,517,182.22
<12 Months	---	---	07/14/2029	---	276,521,170.12	274,453,406.54	275,585,961.56
---	---	---	<b>07/25/2028</b>	---	<b>408,380,310.83</b>	<b>405,760,597.08</b>	<b>407,301,630.76</b>

\* Grouped by: Maturity Bands. \* Groups Sorted by: Maturity Bands. \* Filtered By: Identifier ≠ "CCYUSD". \* Weighted by: Base Market Value + Accrued. \* Holdings Displayed by: Position.

Exhibit "B"  
**Irvine Ranch Water District**  
**Summary of Fixed and Variable Rate Debt**  
**April 2026**

**Current Debt Mix By Type**

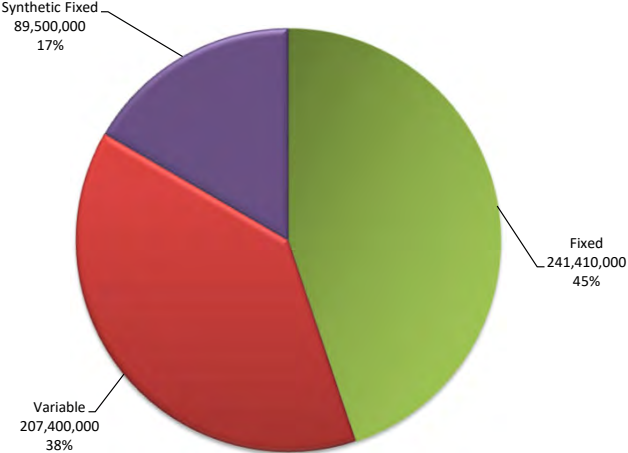

**Letters of Credit / Support**

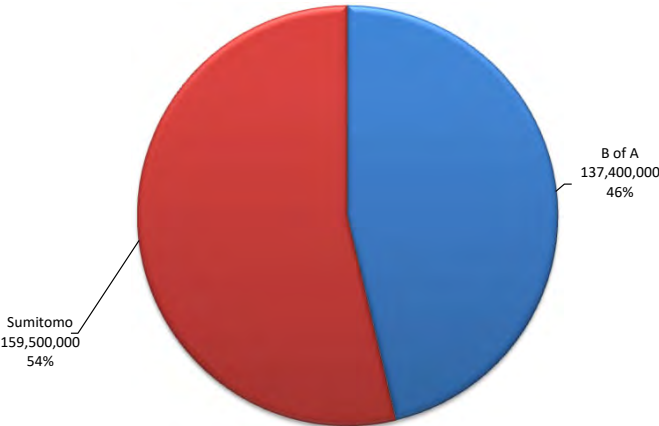

**Current Debt Rate Reset**

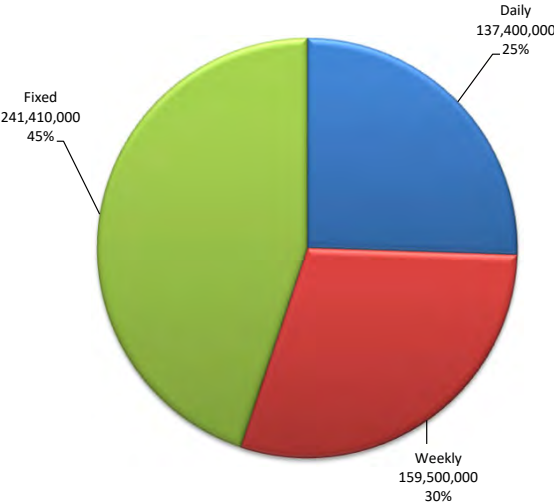

**Outstanding Par by Series**

Series	Issue Date	Maturity Date	Remaining Principal	Percent	Letter of Credit/Support	Rmkt Agent	Mode	Reset
Series 2008-A Refunding	04/24/08	07/01/35	\$34,500,000	6.41%	Sumitomo	BAML	Variable	Weekly
Series 2025-A Refunding	07/15/25	05/01/40	\$125,000,000	23.22%	Sumitomo	BAML	Variable	Weekly
Series 2011-A-1 Refunding	04/15/11	10/01/37	\$34,440,000	6.40%	B of A	Goldman	Variable	Daily
Series 2011-A-2 Refunding	04/15/11	10/01/37	\$22,960,000	4.27%	B of A	Goldman	Variable	Daily
Series 2009 - A	06/04/09	10/01/41	\$40,000,000	7.43%	B of A	US Bank	Variable	Daily
Series 2009 - B	06/04/09	10/01/41	\$40,000,000	7.43%	B of A	Goldman	Variable	Daily
2016 COPS	09/01/16	03/01/46	\$92,030,000	17.10%	N/A	N/A	Fixed	Fixed
Series 2025-B Refunding	07/25/25	05/01/35	\$57,890,000	10.75%	N/A	N/A	Fixed	Fixed
Series 2016	10/12/16	02/01/46	\$91,490,000	17.00%	N/A	N/A	Fixed	Fixed
<b>Total</b>			<b>\$538,310,000</b>	<b>100.00%</b>				

IRVINE RANCH WATER DISTRICT  
SUMMARY OF FIXED & VARIABLE RATE DEBT

April-26

Daily
Weekly

GENERAL BOND INFORMATION							LETTER OF CREDIT INFORMATION										TRUSTEE INFORMATION							
VARIABLE RATE ISSUES	Issue Date	Maturity Date	Principal Payment Date	Payment Date	Original Par Amount	Remaining Principal	Letter of Credit	Reimbursement Agreement Date	L/C Exp. Date	Prior Letter of Credit Bank	MOODYS	S&P	FITCH	LOC Stated Amount	LOC Fee	Annual LOC Cost	Rmkt Agent	Reset	Rmkt Fees	Annual Cost	Trustee			
SERIES 2008-A Refunding	04/24/08	07/01/35	Jul 1	5th Bus. Day	\$60,215,000	\$34,500,000	SUMITOMO	04/01/11	03/13/28	SUMITOMO	A1/P-1	A/A-1	A/F1	\$35,010,411	0.3400%	\$119,035	BAML	WED	0.07%	\$24,150	BANK OF NY			
SERIES 2025-A Refunding	07/15/25	05/01/40	May 1, 2035	1st Bus. Day	\$125,000,000	\$125,000,000	SUMITOMO	07/01/25	07/25/29	SUMITOMO	NA	A/A	A/F1	\$127,054,795	0.3150%	\$400,223	BAML	WED	0.07%	\$87,500	US BANK			
SERIES 2011-A-1 Refunding	04/15/11	10/01/37	Oct 1	1st Bus. Day	\$60,545,000	\$34,440,000	B of A	02/01/24	02/08/27	B of A	Aa1/VMIG1	A+/A-1	AAA/F1+	\$34,824,973	0.3200%	\$111,440	Goldman	DAILY	0.07%	\$24,108	BANK OF NY			
SERIES 2011-A-2 Refunding	04/15/11	10/01/37	Oct 1	1st Bus. Day	\$40,370,000	\$22,960,000	B of A	02/01/24	02/08/27	B of A	Aa1/VMIG1	A+/A-1	AAA/F1+	\$23,216,649	0.3200%	\$74,293	Goldman	DAILY	0.07%	\$16,072	BANK OF NY			
SERIES 2009 - A	06/04/09	10/01/41	Oct 1	1st Bus. Day	\$75,000,000	\$40,000,000	B of A	04/01/25	05/01/28	US BANK	Aa1/VMIG1	A+/A-1	AAA/F1+	\$40,447,123	0.3400%	\$137,520	US Bank	DAILY	0.07%	\$28,000	US BANK			
SERIES 2009 - B	06/04/09	10/01/41	Oct 1	1st Bus. Day	\$75,000,000	\$40,000,000	B of A	04/01/11	05/01/28	B of A	Aa1/VMIG1	A+/A-1	AAA/F1+	\$40,447,123	0.3400%	\$137,520	Goldman	DAILY	0.07%	\$28,000	US BANK			
					<b>\$436,130,000</b>	<b>\$296,900,000</b>	<b>SUB-TOTAL VARIABLE RATE DEBT</b>										<b>\$301,001,074</b>	<b>0.3256%</b>	<b>\$980,032</b>	<b>0.07%</b> <b>\$207,830</b>				
																	(Wt. Avg)			(Wt. Avg)				
FIXED RATE ISSUES																								
2016 COPS	09/01/16	03/01/46	Mar 1	Mar/Sept	\$116,745,000	\$92,030,000	N/A	N/A	N/A	N/A	NR	AAA	AAA	N/A	N/A	N/A	N/A	N/A	N/A	N/A	US BANK			
SERIES 2016	10/12/16	02/01/46	Feb 1	Feb/Aug	\$103,400,000	\$91,490,000	N/A	N/A	N/A	N/A	NR	AAA	AAA	N/A	N/A	N/A	N/A	N/A	N/A	N/A	BANK OF NY			
SERIES 2025B Refunding	07/15/25	05/01/35	May 1, 2026	May/Nov	\$57,890,000	\$57,890,000	N/A	N/A	N/A	N/A	NR	AAA	AAA	N/A	N/A	N/A	N/A	N/A	N/A	N/A	US BANK			
					<b>\$278,035,000</b>	<b>\$241,410,000</b>	<b>SUB-TOTAL FIXED RATE DEBT</b>																	
					<b>\$714,165,000</b>	<b>\$538,310,000</b>	<b>TOTAL- FIXED &amp; VARIABLE RATE DEBT</b>																	

Remarketing Agents			GO VS COP's		
Goldman	97,400,000	33%	GO:	446,280,000	83%
BAML	159,500,000	54%	COPS:	92,030,000	17%
US Bank	40,000,000	13%	Total	<u>538,310,000</u>	
	<u>296,900,000</u>				

LOC Banks			Breakdown Between Variable & Fixed Rate Mode		
SUMITOMO	159,500,000	54%	Daily Issues	137,400,000	26%
BANK OF AMERICA	137,400,000	46%	Weekly Issues	159,500,000	30%
	<u>296,900,000</u>		Sub-Total	<u>296,900,000</u>	
			Fixed Rate Issues	\$241,410,000	45%
			Sub-Total - Fixed	<u>241,410,000</u>	
			TOTAL DEBT		
			FIXED & VAR.	<u>538,310,000</u>	100%

SUMMARY OF DEBT RATES

Apr-26

Cusips	4636324K2	4636324Q9	4636324R7	4636324D8	4636325R6	4636324H9
Rmkt Agent	GOLDMAN	GOLDMAN	GOLDMAN	MERRILL LYNCH	MERRILL LYNCH	US BANK
Mode	DAILY	DAILY	DAILY	WEEKLY	WEEKLY	DAILY
Bond Issue	2009 - B	2011 A-1	2011 A-2	2008-A	2025 - A	2009-A
Par Amount	40,000,000	34,440,000	22,960,000	34,500,000	125,000,000	40,000,000
LOC Bank	BOFA	BOFA	BOFA	Sumitomo	Sumitomo	BOFA
Reset				Wednesday	Wednesday	
4/1/2026	1.20%	1.20%	1.20%	1.65%	1.65%	1.70%
4/2/2026	1.25%	1.25%	1.25%	1.70%	1.70%	1.50%
4/3/2026	1.25%	1.25%	1.25%	1.70%	1.70%	1.50%
4/4/2026	1.25%	1.25%	1.25%	1.70%	1.70%	1.50%
4/5/2026	1.25%	1.25%	1.25%	1.70%	1.70%	1.50%
4/6/2026	1.60%	1.60%	1.60%	1.70%	1.70%	1.50%
4/7/2026	1.60%	1.60%	1.60%	1.70%	1.70%	1.70%
4/8/2026	2.15%	2.15%	2.15%	1.70%	1.70%	2.10%
4/9/2026	2.80%	2.80%	2.80%	2.14%	2.14%	2.70%
4/10/2026	3.15%	3.15%	3.15%	2.14%	2.14%	3.10%
4/11/2026	3.15%	3.15%	3.15%	2.14%	2.14%	3.10%
4/12/2026	3.15%	3.15%	3.15%	2.14%	2.14%	3.10%
4/13/2026	3.15%	3.15%	3.15%	2.14%	2.14%	3.20%
4/14/2026	3.20%	3.20%	3.20%	2.14%	2.14%	3.25%
4/15/2026	3.30%	3.30%	3.30%	2.14%	2.14%	3.25%
4/16/2026	3.30%	3.30%	3.30%	3.00%	3.00%	3.15%
4/17/2026	3.30%	3.30%	3.30%	3.00%	3.00%	3.25%
4/18/2026	3.30%	3.30%	3.30%	3.00%	3.00%	3.25%
4/19/2026	3.30%	3.30%	3.30%	3.00%	3.00%	3.25%
4/20/2026	3.25%	3.25%	3.25%	3.00%	3.00%	3.20%
4/21/2026	3.30%	3.30%	3.30%	3.00%	3.00%	3.20%
4/22/2026	3.30%	3.30%	3.30%	3.00%	3.00%	3.20%
4/23/2026	3.30%	3.30%	3.30%	2.97%	2.97%	3.20%
4/24/2026	3.30%	3.30%	3.30%	2.97%	2.97%	3.20%
4/25/2026	3.30%	3.30%	3.30%	2.97%	2.97%	3.20%
4/26/2026	3.30%	3.30%	3.30%	2.97%	2.97%	3.20%
4/27/2026	3.20%	3.20%	3.20%	2.97%	2.97%	3.10%
4/28/2026	3.05%	3.05%	3.05%	2.97%	2.97%	3.00%
4/29/2026	3.05%	3.05%	3.05%	2.97%	2.97%	3.00%
4/30/2026	3.00%	3.00%	3.00%	2.45%	2.45%	3.05%
Avg Interest Rates	2.73%	2.73%	2.73%	2.43%	2.43%	2.74%
Rmkt Fee	0.07%	0.07%	0.07%	0.07%	0.07%	0.07%
LOC Fee	0.34%	0.32%	0.32%	0.34%	0.32%	0.34%
<b>All-In Rate</b>	<b>3.14%</b>	<b>3.12%</b>	<b>3.12%</b>	<b>2.84%</b>	<b>2.81%</b>	<b>3.15%</b>
Par Amount		97,400,000		159,500,000		40,000,000

Interest Rate Mode	Percent of Total Variable Rate Debt	Par Outstanding	Weighted All-In Average Rate	Base Rate Average
Daily	46.28%	137,400,000	3.14%	2.73%
Weekly	53.72%	159,500,000	2.82%	2.43%
<b>Fixed</b>	<b>100.00%</b>	<b>\$296,900,000</b>	<b>2.96%</b>	<b>2.57%</b>
COPS 2016	38.12%	92,030,000	2.90%	
SERIES 2025 B	23.98%	57,890,000	2.77%	
SERIES 2016	37.90%	91,490,000	3.32%	
	<b>100.00%</b>	<b>\$241,410,000</b>	<b>3.03%</b>	
All-In Debt Rate Including \$60 Million Notional Amount of Swaps				<b>3.18%</b>

Note: This page is intentionally left blank.

Exhibit "C"  
**Irvine Ranch Water District**  
**Interest Rate Swap Summary**  
**April 2026**

	Prior Mo.	Current Mo.	12-Mo Avg
SFR1M (Lbr Rpl) Avg %	3.79%	3.77%	4.04%

Current Fiscal Year Active Swaps								Cash Flow				(Since 3/07)	Mark to Market	
Effective Date	Maturity Date	Years to Maturity	Counter Party	Notional Amt	Type	Base Index	Fixed Rate	Prior Month	Current Month	Fiscal YTD	Cumulative Net Accrual	Current Mark to Market	Notional Difference	
<b>Fixed Payer Swaps - By Effective Date</b>														
3/10/2007	3/10/2029	2.9	ML	30,000,000	FXP	LIBOR	5.687%	(49,234)	(43,041)	(370,330)	(22,608,786)	28,470,374	(1,529,626)	
3/10/2007	3/10/2029	2.9	CG	30,000,000	FXP	LIBOR	5.687%	(49,234)	(43,041)	(370,330)	(22,608,579)	28,469,445	(1,530,555)	
<b>Totals/Weighted Avgs</b>				<b>\$ 60,000,000</b>			<b>5.687%</b>	<b>\$ (98,468)</b>	<b>\$ (86,082)</b>	<b>\$ (740,660)</b>	<b>\$ (45,217,366)</b>	<b>\$ 56,939,819</b>	<b>\$ (3,060,181)</b>	
<b>Total Current Year Active Swaps</b>				<b>\$ 60,000,000</b>				<b>\$ (98,468)</b>	<b>\$ (86,082)</b>	<b>\$ (740,660)</b>	<b>\$ (45,217,366)</b>	<b>\$ 56,939,819</b>	<b>\$ (3,060,181)</b>	

Current Fiscal Year Terminated Swaps								Cash Flow				Mark to Market	
Effective Date	Maturity Date		Counter Party	Notional Amt	Type	Base Index	Fixed Rate	Prior Month	Current Month	Fiscal YTD	Cumulative Net Accrual	Current Mark to Market	Notional Difference
<b>Total Current Year Terminated Swaps</b>								<b>\$ -</b>	<b>\$ -</b>	<b>\$ -</b>	<b>\$ -</b>	<b>\$ -</b>	<b>\$ -</b>

Current Fiscal Year - Total Swaps								Cash Flow				Mark to Market		
Effective Date	Maturity Date		Counter Party	Notional Amt	Type	Base Index	Fixed Rate	Prior Month	Current Month	Fiscal YTD	Cumulative Net Accrual	Current Mark to Market	Notional Difference	
<b>Total Current Year Active &amp; Terminated Swaps</b>								<b>\$ 60,000,000</b>	<b>\$ (98,468)</b>	<b>\$ (86,082)</b>	<b>\$ (740,660)</b>	<b>\$ (45,217,366)</b>	<b>\$ 56,939,819</b>	<b>\$ (3,060,181)</b>

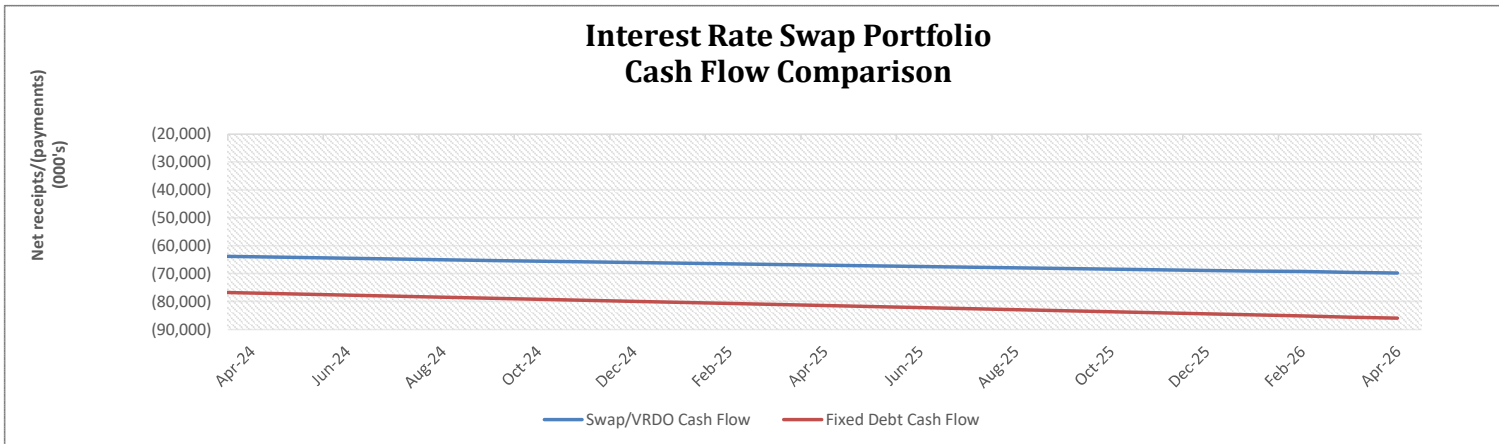

Cash Flow Comparison Synthetic Fixed vs. Fixed Rate Debt	
Cash Flow to Date	
Synthetic Fixed =	\$69,776,099
Fixed Rate =	\$85,907,090
<b>Assumptions:</b>	
- Fixed rate debt issued at 4.93% in Mar-07 (estimated TE rate - Bloomberg)	
- 'Synthetic' includes swap cash flow + interest + fees to date	

Note: This page is intentionally left blank.

## Exhibit "D"

### IRVINE RANCH WATER DISTRICT AP DISBURSEMENTS AND VOIDS FOR APRIL 2026

CHECK OR ELECTRONIC #	PAYMENT DATE	SUPPLIER	PAYMENT AMOUNT
454518	2-Apr-26	US BANK NAT'L ASSOCIATION NORTH DAKOTA	108,589.87
454519	2-Apr-26	FEDEX	328.42
454520	2-Apr-26	COLONIAL LIFE & ACCIDENT INSURANCE CO.	370.32
454521	2-Apr-26	COX COMMUNICATIONS, INC.	402.29
454522	2-Apr-26	EAST ORANGE COUNTY WATER DISTRICT	1,298.01
454523	2-Apr-26	AMERICAN WATER WORKS ASSOC	13,425.00
454524	2-Apr-26	APCO GRAPHICS INC	209.59
454525	2-Apr-26	APPLIED INDUSTRIAL TECHNOLOGIES - CA LLC	4,435.07
454526	2-Apr-26	ORANGE COUNTY FIRE PROTECTION, INC.	6,304.21
454527	2-Apr-26	POLLARDWATER.COM	9,288.83
454528	2-Apr-26	LINDE GAS & EQUIPMENT INC.	3,240.65
454529	2-Apr-26	SOUTH COAST AIR QUALITY MANAGEMENT DISTRICT	4,248.48
454530	2-Apr-26	SOUTHERN CALIFORNIA EDISON COMPANY	76.25
454531	2-Apr-26	SOUTHERN CALIFORNIA EDISON COMPANY	86,557.05
454532	2-Apr-26	SOUTHERN COUNTIES LUBRICANTS LLC	1,240.70
454533	2-Apr-26	UNITED PARCEL SERVICE INC	129.05
454534	2-Apr-26	V&A CONSULTING ENGINEERS	18,233.00
454535	2-Apr-26	FRONTIER CALIFORNIA INC.	582.43
454536	2-Apr-26	VERIZON WIRELESS SERVICES LLC	18,497.74
454537	2-Apr-26	WAXIE'S ENTERPRISES, LLC, A BRADYPLUS COMPANY	2,685.75
454538	2-Apr-26	AIRGAS, INC.	2,083.04
454539	2-Apr-26	GRAYBAR ELECTRIC COMPANY	3,955.69
454540	2-Apr-26	DAIOHS USA INCORPORATED	3,763.74
454541	2-Apr-26	AT&T CORP	231.33
454542	2-Apr-26	AT&T CORP	724.73
454543	2-Apr-26	AT&T CORP	67.84
454544	2-Apr-26	HACH COMPANY	22,194.19
454545	2-Apr-26	GEI CONSULTANTS INC	6,772.50
454546	2-Apr-26	SEAL ANALYTICAL INC	93.10
454547	2-Apr-26	DELL MARKETING LP	19.95
454548	2-Apr-26	TK ELEVATOR CORPORATION	598.93
454549	2-Apr-26	CHEM-TECH INTERNATIONAL INC	28,614.97
454550	2-Apr-26	LEE & RO, INC.	16,159.00
454551	2-Apr-26	FITCH RATINGS, INC.	7,000.00
454552	2-Apr-26	ENDRESS AND HAUSER INC	985.44
454553	2-Apr-26	DIRECTV INC	159.99
454554	2-Apr-26	MILES CHEMICAL COMPANY, INC.	12,990.81
454555	2-Apr-26	AIR TECHNOLOGY LABORATORIES	203.50
454556	2-Apr-26	ARCADIS U.S., INC.	23,170.00
454557	2-Apr-26	QUADIENT LEASING USA, INC.	2,131.24
454558	2-Apr-26	INTERNATIONAL LINE BUILDERS	1,098.93
454559	2-Apr-26	SANTA MARGARITA FORD	7,612.43
454560	2-Apr-26	SANTA MARGARITA FORD	3,594.10
454561	2-Apr-26	SOUTH BAY FOUNDRY, INC	5,559.90
454562	2-Apr-26	FUSCOE ENGINEERING, INC.	9,165.00
454563	2-Apr-26	B & H PHOTO VIDEO	2,352.72
454564	2-Apr-26	KO, CAROL	91.31

IRVINE RANCH WATER DISTRICT  
AP DISBURSEMENTS AND VOIDS FOR APRIL 2026

CHECK OR ELECTRONIC #	PAYMENT DATE	SUPPLIER	PAYMENT AMOUNT
454565	2-Apr-26	CHEN, GANG	19.30
454566	2-Apr-26	POWELL CONSTRUCTORS INC	1,431.89
454567	2-Apr-26	IDEA HALL	6,717.50
454568	2-Apr-26	ACCUSOURCE, INC.	456.98
454569	2-Apr-26	INFOSEND, INC.	36,429.58
454570	2-Apr-26	DIVERSIFIED COMMUNICATIONS SERVICES, INC.	8,584.00
454571	2-Apr-26	ARMADILLO AUTOMATION, INC.	10,016.30
454572	2-Apr-26	PLANETBIDS, INC.	1,986.30
454573	2-Apr-26	BIOTAGE LLC	174.53
454574	2-Apr-26	O'REILLY AUTO ENTERPRISES, LLC	209.56
454575	2-Apr-26	KIM, YOUNGIL	20.95
454576	2-Apr-26	NICK BARBIERI TRUCKING, LLC	5,417.53
454577	2-Apr-26	STANTEC ARCHITECTURE INC	15,728.50
454578	2-Apr-26	CENTURY PAVING INC	2,824.71
454579	2-Apr-26	MICHAEL K. NUNLEY & ASSOCIATES, LLP	41,328.75
454580	2-Apr-26	REECE SUPPLY LLC	865.32
454581	2-Apr-26	BPS SUPPLY GROUP	5,101.27
454582	2-Apr-26	WANG, XIN	37.40
454583	2-Apr-26	SOCAL SCADA SOLUTIONS LLC	15,420.00
454584	2-Apr-26	CONTINENTAL AMERICAN INSURANCE COMPANY	1,819.62
454585	2-Apr-26	WU, JACQUELINE	81.68
454586	2-Apr-26	VINCE TURSINI	2,593.00
454587	2-Apr-26	DO SUPPLY COMPANY INC	1,828.52
454588	2-Apr-26	IRON MOUNTAIN INCORPORATED	107.13
454589	2-Apr-26	FISHER ROSEMOUNT SYSTEMS INC.	3,857.91
454590	2-Apr-26	JO-KELL, INC.	4,025.91
454591	2-Apr-26	BLUETRITON BRANDS INC	176.12
454592	2-Apr-26	PARK, KATIE	45.06
454593	2-Apr-26	TOYOTA MOTOR SALES	6,966.60
454594	2-Apr-26	NEXUS HOLDING, LLC	860.00
454595	2-Apr-26	GEO PAVING AND SEAL COATING	50,486.00
454596	2-Apr-26	DN TANKS LLC	3,291.00
454597	2-Apr-26	DN TANKS LLC	222,922.14
454598	2-Apr-26	KO, KIT	56.04
454599	2-Apr-26	ESKILL CORPORATION	10,000.00
454600	2-Apr-26	PROMISE PROPERTY MANAGEMENT	97.53
454601	2-Apr-26	MORRIS, DEBORAH	16.45
454602	2-Apr-26	ECAQ INVESTMENTS LLC	60.54
454603	2-Apr-26	GUEVERA, VICSON	55.79
454604	2-Apr-26	WANIEK, ALEX	76.82
454605	2-Apr-26	HANNA, GEOZEPH	23.71
454606	2-Apr-26	KPRS CONSTRUCTION SERVICE INC	977.00
454607	2-Apr-26	BODE, JOSH	278.88
454608	2-Apr-26	JOHNSON, KRISTEN	57.80
454609	2-Apr-26	LIM, CAROL	71.46
454610	2-Apr-26	HANSEN, LORI	3,023.57
454611	2-Apr-26	TURTLE ROCK GLEN COMM ASSN	1,030.77

IRVINE RANCH WATER DISTRICT  
AP DISBURSEMENTS AND VOIDS FOR APRIL 2026

CHECK OR ELECTRONIC #	PAYMENT DATE	SUPPLIER	PAYMENT AMOUNT
454612	2-Apr-26	CUSA CONSULTING	3,026.78
454613	2-Apr-26	BOGART CONSTRUCTION	1,392.67
454614	2-Apr-26	DSD - WEEKS & FALCONE CONSTRUCTION, INC	1,031.09
454615	2-Apr-26	ORANGE COAST DISTRICT	1,590.18
454616	2-Apr-26	HO, DANIEL	133.23
454617	2-Apr-26	HAN, JING	129.85
454618	2-Apr-26	GLASS, MICHAEL	20.29
454619	2-Apr-26	GRAMA, PRAKASH	15.57
454620	2-Apr-26	HOE, MICHELLE	25.78
454621	2-Apr-26	HSU, SHIH- HSUAN	16.85
454622	2-Apr-26	KALVODA, KATIE	24.59
454623	2-Apr-26	STONETREE MANOR COMMUNITY ASSN	4,358.55
454624	2-Apr-26	JOHNSON, ANDREA L	65.03
454625	2-Apr-26	LI, YE	23.02
454626	2-Apr-26	HARTFORD LIFE AND ACCIDENT INSURANCE COMPANY	18.74
454627	2-Apr-26	INTERNAL REVENUE SERVICE	2,105.15
454628	2-Apr-26	AMERICAN FAMILY LIFE ASSURANCE COMPANY OF COLUMBUS	3,801.54
454629	2-Apr-26	LOEB & LOEB LLP	5,000.00
454630	2-Apr-26	CALIFORNIA SECRETARY OF STATE	40.00
454631	9-Apr-26	BAVCO BACKFLOW APPARATUS & VALVE COMPANY	119.00
454632	9-Apr-26	FEDEX	362.86
454633	9-Apr-26	FISHER SCIENTIFIC COMPANY, LLC	6,174.03
454634	9-Apr-26	GALLADE CHEMICAL INC	2,883.39
454635	9-Apr-26	HARRINGTON INDUSTRIAL PLASTICS LLC	10,209.53
454636	9-Apr-26	IRVINE UNIFIED SCHOOL DISTRICT	1,245.69
454637	9-Apr-26	BRUCE HADLEY NEWELL	1,250.00
454638	9-Apr-26	CITY OF TUSTIN	428.10
454639	9-Apr-26	COLONIAL LIFE & ACCIDENT INSURANCE CO.	370.32
454640	9-Apr-26	CORELOGIC INC	752.00
454641	9-Apr-26	ADS CORP.	2,781.00
454642	9-Apr-26	AGILENT TECHNOLOGIES, INC.	1,157.18
454643	9-Apr-26	POLLARDWATER.COM	8,121.53
454644	9-Apr-26	LINDE GAS & EQUIPMENT INC.	1,370.32
454645	9-Apr-26	SHAMROCK SUPPLY COMPANY, INC.	7,440.80
454646	9-Apr-26	SOUTH COAST AIR QUALITY MANAGEMENT DISTRICT	736.57
454647	9-Apr-26	SOUTH COAST WATER CO.	50.00
454648	9-Apr-26	SOUTHERN CALIFORNIA EDISON COMPANY	324,237.10
454649	9-Apr-26	STERIS CORPORATION	1,310.00
454650	9-Apr-26	THIRKETTLE CORPORATION	174,837.20
454651	9-Apr-26	UNITED PARCEL SERVICE INC	138.51
454652	9-Apr-26	AIRGAS, INC.	3,346.26
454653	9-Apr-26	GRAYBAR ELECTRIC COMPANY	90.16
454654	9-Apr-26	FERGUSON US HOLDINGS, INC.	28,626.59
454655	9-Apr-26	AT&T CORP	3,990.92
454656	9-Apr-26	ONESOURCE DISTRIBUTORS, LLC	17,406.29
454657	9-Apr-26	UNITED SITE SERVICES OF CALIFORNIA INC	405.98
454658	9-Apr-26	HACH COMPANY	11,242.89

IRVINE RANCH WATER DISTRICT  
AP DISBURSEMENTS AND VOIDS FOR APRIL 2026

CHECK OR ELECTRONIC #	PAYMENT DATE	SUPPLIER	PAYMENT AMOUNT
454659	9-Apr-26	MOTION INDUSTRIES INC	158.55
454660	9-Apr-26	GEI CONSULTANTS INC	24,142.50
454661	9-Apr-26	FIERRO, SERGIO D	4,662.00
454662	9-Apr-26	DELL MARKETING LP	2,015.53
454663	9-Apr-26	IRVINE COMMUNITY DEVELOPMENT COMPANY LLC	180,691.50
454664	9-Apr-26	CHEM-TECH INTERNATIONAL INC	9,552.05
454665	9-Apr-26	REFRIGERATION SUPPLIES DISTRIBUTOR	1,152.44
454666	9-Apr-26	ARAKELIAN ENTERPRISES, INC.	1,750.93
454667	9-Apr-26	ENDRESS AND HAUSER INC	2,520.00
454668	9-Apr-26	CORO SOUTHERN CALIFORNIA	2,500.00
454669	9-Apr-26	DEALERS SERVICE COMPANY, INC	13,982.66
454670	9-Apr-26	STRADLING YOCCA CARLSON & RAUTH	240.00
454671	9-Apr-26	ARCADIS U.S., INC.	31,711.25
454672	9-Apr-26	WATEREUSE ASSOCIATION	5,000.00
454673	9-Apr-26	MULTI W SYSTEMS, INC.	45,718.48
454674	9-Apr-26	SANTA MARGARITA FORD	1,191.84
454675	9-Apr-26	KAESER COMPRESSORS, INC.	36,601.08
454676	9-Apr-26	PACIFIC EH&S SERVICES, INC.	4,256.64
454677	9-Apr-26	SITMATIC	5,018.78
454678	9-Apr-26	VEOLIA WATER TECHNOLOGIES TREATMENT SOLUTIONS USA INC.	4,068.26
454679	9-Apr-26	DXP ENTERPRISES, INC.	1,084.40
454680	9-Apr-26	LINKEDIN CORPORATION	6,390.00
454681	9-Apr-26	THE PARK AT IRVINE SPECTRUM	4,391.36
454682	9-Apr-26	STATE OF CALIFORNIA, DEPARTMENT OF WATER RESOURCES	155,221.00
454683	9-Apr-26	BOFA SECURITIES, INC.	22,054.79
454684	9-Apr-26	DG INVESTMENT INTERMEDIATE HOLDINGS 2, INC.	1,261.00
454685	9-Apr-26	HI-LINE INC	400.21
454686	9-Apr-26	SERVER SUPPLY.COM, INC	669.45
454687	9-Apr-26	SOUTHERN CONTRACTING COMPANY	192,817.89
454688	9-Apr-26	FASTBLUE COMMUNICATIONS INC.	3,600.95
454689	9-Apr-26	WASTE MANAGEMENT COLLECTIONS AND RECYCLING, INC.	18,932.74
454690	9-Apr-26	ALAN SMITH POOL PLASTERING, INC	2,823.09
454691	9-Apr-26	CITADEL ENVIRONMENTAL SERVICES, INC.	29,977.00
454692	9-Apr-26	THOMPSON & PHIPPS INC	6,146.12
454693	9-Apr-26	8X8 INC	12,151.65
454694	9-Apr-26	ROMAN JAMES DESIGN BUILD	1,544.87
454695	9-Apr-26	THE BALDWIN GROUP WEST, LLC	5,833.33
454696	9-Apr-26	VISTA PAINT CORPORATION	325.98
454697	9-Apr-26	LOZANO SMITH, LLP	4,217.50
454698	9-Apr-26	SCA OF CA, LLC	1,521.08
454699	9-Apr-26	MICHAEL K. NUNLEY & ASSOCIATES, LLP	11,956.25
454700	9-Apr-26	DOWNSTREAM SERVICES INC	3,047.42
454701	9-Apr-26	REECE SUPPLY LLC	229.67
454702	9-Apr-26	QUALTRAX, INC.	18,233.51
454703	9-Apr-26	BPS SUPPLY GROUP	798.81
454704	9-Apr-26	CULVER CAR WASH LLC	65.98
454705	9-Apr-26	ELIJAH STANDING WARRIOR	1,500.00

IRVINE RANCH WATER DISTRICT  
AP DISBURSEMENTS AND VOIDS FOR APRIL 2026

CHECK OR ELECTRONIC #	PAYMENT DATE	SUPPLIER	PAYMENT AMOUNT
454706	9-Apr-26	MIKE PRLICH AND SONS, INC.	530,803.00
454707	9-Apr-26	CANON U.S.A., INC.	6,606.92
454708	9-Apr-26	VOICE, LLC	1,340.45
454709	9-Apr-26	ADVANCED INTEGRATION & CONTROLS	35,600.00
454710	9-Apr-26	PROGROUP	278.45
454711	9-Apr-26	JO-KELL, INC.	3,046.75
454712	9-Apr-26	EUNA SOLUTIONS, INC	101,328.00
454713	9-Apr-26	CINTAS CORPORATION NO. 2	1,125.28
454714	9-Apr-26	JO, IAN	112.15
454715	9-Apr-26	GCP WW HOLDCO LLC	2,697.88
454716	9-Apr-26	EVERGREEN ALLIANCE PROFESSIONAL CORPORATION	4,400.00
454717	9-Apr-26	ENVIRONMENTAL CONSTRUCTION, INC	559.96
454718	9-Apr-26	TASHIRO CHOI & ASSOCIATES	14,000.00
454719	9-Apr-26	RITA AHMED AND HASNAIN SOMJI	192.34
454720	9-Apr-26	CCL CONTRACTING INC	2,803.42
454721	9-Apr-26	KENMORE, CHRISTOPHER	21.13
454722	9-Apr-26	NADDOUR, JOSEPH	860.43
454723	9-Apr-26	T-9 ENTERPRISE INC	752.96
454724	9-Apr-26	JIN, APRIL	158.24
454725	9-Apr-26	NEPP, PATRICIA	58.11
454726	9-Apr-26	SUNARTA, DAVID	92.30
454727	9-Apr-26	SMITH, AARON	58.11
454728	9-Apr-26	LIU, JUNLING	18.96
454729	9-Apr-26	HONG, OUI BEOM	64.62
454730	9-Apr-26	A J PADELFORD SON INC	3,342.41
454731	9-Apr-26	WEI ZHOU AND JIAYU BI	17.83
454732	9-Apr-26	GEBARA, ROXANE	48.07
454733	9-Apr-26	SILES, RUTH	47.30
454734	9-Apr-26	SHAOLIAN, ROZITA	42.20
454735	9-Apr-26	LIM, DORIS	55.36
454736	9-Apr-26	FINKELBERG, STEVEN	23.71
454737	9-Apr-26	XIAO, HONG	28.38
454738	9-Apr-26	LEE, DONG	89.74
454739	9-Apr-26	PHAM, MINHCHAU	1,529.05
454740	9-Apr-26	ROGALLA, SHAWNNA	59.24
454741	9-Apr-26	PAULA, RICHARD	25.21
454742	9-Apr-26	KINCADE, STEVE	20.86
454743	9-Apr-26	COUNTY OF ORANGE	2,800.00
454744	9-Apr-26	INTERNATIONAL BROTHERHOOD OF ELECTRICAL WORKERS LOCAL 47	11,555.16
454745	16-Apr-26	BAVCO BACKFLOW APPARATUS & VALVE COMPANY	216.90
454746	16-Apr-26	BLOOMBERG FINANCE LP	7,995.00
454747	16-Apr-26	FARWEST CORROSION CONTROL COMPANY	5,046.04
454748	16-Apr-26	FEDEX	98.34
454749	16-Apr-26	FISHER SCIENTIFIC COMPANY, LLC	862.89
454750	16-Apr-26	HARRINGTON INDUSTRIAL PLASTICS LLC	843.86
454751	16-Apr-26	CANON FINANCIAL SERVICES, INC.	9,790.47
454752	16-Apr-26	CITY OF SANTA ANA	672.06

IRVINE RANCH WATER DISTRICT  
AP DISBURSEMENTS AND VOIDS FOR APRIL 2026

CHECK OR ELECTRONIC #	PAYMENT DATE	SUPPLIER	PAYMENT AMOUNT
454753	16-Apr-26	CITY OF TUSTIN	672.15
454754	16-Apr-26	CR & R INCORPORATED	690.68
454755	16-Apr-26	MUTUAL PROPANE	218.62
454756	16-Apr-26	NMG GEOTECHNICAL INC	1,914.30
454757	16-Apr-26	PLUMBERS DEPOT INC	28,528.58
454758	16-Apr-26	POLLARDWATER.COM	1,756.62
454759	16-Apr-26	LINDE GAS & EQUIPMENT INC.	4,702.74
454760	16-Apr-26	SOUTHERN CALIFORNIA EDISON COMPANY	390,117.31
454761	16-Apr-26	SOUTHWEST VALVE & EQUIPMENT, LLC	17,332.89
454762	16-Apr-26	STERIS CORPORATION	9,476.34
454763	16-Apr-26	THIRKETTLE CORPORATION	140,087.35
454764	16-Apr-26	UNITED PARCEL SERVICE INC	74.53
454765	16-Apr-26	FRONTIER CALIFORNIA INC.	79.28
454766	16-Apr-26	VERIZON WIRELESS SERVICES LLC	1,072.74
454767	16-Apr-26	WALTERS WHOLESALE ELECTRIC CO	1,194.82
454768	16-Apr-26	USA WASTE OF CALIFORNIA, INC.	752.99
454769	16-Apr-26	WAXIE'S ENTERPRISES, LLC, A BRADYPLUS COMPANY	2,064.53
454770	16-Apr-26	INDUSTRIAL METAL SUPPLY CO	245.56
454771	16-Apr-26	GRAYBAR ELECTRIC COMPANY	29.70
454772	16-Apr-26	SOUTHERN CALIFORNIA GAS COMPANY	5,630.92
454773	16-Apr-26	AT&T CORP	161.34
454774	16-Apr-26	AT&T CORP	220.74
454775	16-Apr-26	AT&T CORP	2,063.06
454776	16-Apr-26	ONESOURCE DISTRIBUTORS, LLC	4,278.75
454777	16-Apr-26	UNITED SITE SERVICES OF CALIFORNIA INC	1,298.88
454778	16-Apr-26	HACH COMPANY	4,383.07
454779	16-Apr-26	MOTION INDUSTRIES INC	1,113.17
454780	16-Apr-26	SOUTH COAST WATER DISTRICT	1,290.44
454781	16-Apr-26	IRVINE COMMUNITY DEVELOPMENT COMPANY LLC	32,232.00
454782	16-Apr-26	TK ELEVATOR CORPORATION	10,536.95
454783	16-Apr-26	US BANK NAT'L ASSOC N.DAKOTA	6,904.10
454784	16-Apr-26	VULCAN MATERIALS COMPANY	2,410.81
454785	16-Apr-26	NEWPORT BEACH CHAMBER OF COMMERCE	590.00
454786	16-Apr-26	REFRIGERATION SUPPLIES DISTRIBUTOR	594.52
454787	16-Apr-26	TAIT ENVIRONMENTAL SERVICES, INC.	500.00
454788	16-Apr-26	ARAKELIAN ENTERPRISES, INC.	4,213.39
454789	16-Apr-26	ORACLE AMERICA, INC.	3,129.28
454790	16-Apr-26	FEDEX NATIONAL LTL, INC	377.15
454791	16-Apr-26	GOLDMAN, SACHS & CO. LLC	16,811.51
454792	16-Apr-26	AIR TECHNOLOGY LABORATORIES	203.50
454793	16-Apr-26	ANTHONY N. LARSEN	850.00
454794	16-Apr-26	LSA ASSOCIATES INC	505.00
454795	16-Apr-26	KPRS CONSTRUCTION SERVICES, INC.	298,145.15
454796	16-Apr-26	PARKWAY LAWNMOWER SHOP	6,792.82
454797	16-Apr-26	CHARLES P CROWLEY COMPANY INC	4,242.81
454798	16-Apr-26	BEST DRILLING AND PUMP, INC.	159,923.00
454799	16-Apr-26	ISLE INC	21,780.00

IRVINE RANCH WATER DISTRICT  
AP DISBURSEMENTS AND VOIDS FOR APRIL 2026

CHECK OR ELECTRONIC #	PAYMENT DATE	SUPPLIER	PAYMENT AMOUNT
454800	16-Apr-26	GLADWELL GOVERNMENTAL SERVICES, INC.	450.00
454801	16-Apr-26	SANTA MARGARITA FORD	2,965.43
454802	16-Apr-26	EUROFINS DRINKING WATER AND WASTEWATER WEST, LLC	10,939.49
454803	16-Apr-26	R C FOSTER CORPORATION	133,727.43
454804	16-Apr-26	KAESER COMPRESSORS, INC.	4,718.51
454805	16-Apr-26	GHD INC.	22,266.91
454806	16-Apr-26	PHENOVA, INC.	443.00
454807	16-Apr-26	RESILIENT COMMUNICATIONS INC.	30,932.97
454808	16-Apr-26	GEORGE HILLS COMPANY	547.56
454809	16-Apr-26	SS MECHANICAL CONSTRUCTION CORP	65,852.96
454810	16-Apr-26	GUIDA SURVEYING INC.	5,790.00
454811	16-Apr-26	CCL CONTRACTING INC.	100,992.74
454812	16-Apr-26	FERREIRA CONSTRUCTION CO. INC.	64,831.80
454813	16-Apr-26	INFOSEND, INC.	42,165.89
454814	16-Apr-26	CLIFFORD MORIYAMA	5,000.00
454815	16-Apr-26	RENTOKIL NORTH AMERICA, INC	2,520.00
454816	16-Apr-26	BOFA SECURITIES, INC.	5,954.79
454817	16-Apr-26	DG INVESTMENT INTERMEDIATE HOLDINGS 2, INC.	2,489.50
454818	16-Apr-26	BRAX COMPANY, INC	22,447.76
454819	16-Apr-26	KAN VENTURES, INC	15,850.30
454820	16-Apr-26	EUROFINS ENVIRONMENT TESTING SOUTHWEST	4,446.75
454821	16-Apr-26	SOUTHERN CONTRACTING COMPANY	504,333.63
454822	16-Apr-26	IXOM WATERCARE INC	48,000.00
454823	16-Apr-26	DCS MANAGEMENT LLC	819.08
454824	16-Apr-26	INSITE TELECOM, LLC	16,905.00
454825	16-Apr-26	JENIFER L. KIENLE	1,541.00
454826	16-Apr-26	VEOLIA NORTH AMERICA, INC.	11,886.60
454827	16-Apr-26	TIERRA VERDE INDUSTRIES	53.34
454828	16-Apr-26	VISTA PAINT CORPORATION	694.60
454829	16-Apr-26	HERITAGE FIELDS LLC	1,183,873.38
454830	16-Apr-26	MICHAEL K. NUNLEY & ASSOCIATES, LLP	31,985.93
454831	16-Apr-26	ENEL X ADVISORY SERVICES NORTH AMERICA, INC.	3,300.00
454832	16-Apr-26	REECE SUPPLY LLC	741.31
454833	16-Apr-26	DMS FACILITY SERVICES, LLC	40,347.59
454834	16-Apr-26	SOUNDVIEW, INC.	5,293.00
454835	16-Apr-26	BPS SUPPLY GROUP	2,908.47
454836	16-Apr-26	LUBRICATION ENGINEERS	3,534.11
454837	16-Apr-26	PRIME SYSTEMS INDUSTRIAL AUTOMATION, INC.	8,284.00
454838	16-Apr-26	NATIONAL SAFETY COMPLIANCE, INC	104.50
454839	16-Apr-26	AQUATIC BIOASSAY & CONSULTING LABORATORIES, INC.	1,920.00
454840	16-Apr-26	HUBBELL LENOIR CITY	6,828.87
454841	16-Apr-26	G2 CONSTRUCTION, INC	12,750.00
454842	16-Apr-26	CENTROID INTERMEDIATE, LLC	15,587.88
454843	16-Apr-26	PROGROUP	52.89
454844	16-Apr-26	JLL CALIBRATION ACQUISITION COMPANY	650.00
454845	16-Apr-26	CINTAS CORPORATION NO. 2	718.35
454846	16-Apr-26	M3 NURSERIES INC.	1,355.77

IRVINE RANCH WATER DISTRICT  
AP DISBURSEMENTS AND VOIDS FOR APRIL 2026

CHECK OR ELECTRONIC #	PAYMENT DATE	SUPPLIER	PAYMENT AMOUNT
454847	16-Apr-26	GCP WW HOLDCO LLC	1,465.66
454848	16-Apr-26	NEXUS HOLDING, LLC	1,385.00
454849	16-Apr-26	DENKEN SOLUTIONS, INC	19,030.00
454850	16-Apr-26	HERITAGE LANDSCAPE SUPPLY GROUP, INC.	713.62
454851	16-Apr-26	WITHERS BERGMAN LLP	712.25
454852	16-Apr-26	SUPERIOR TANK COMPANY INC	13,600.00
454853	16-Apr-26	BERNEL INC DBA VFS FIRE & SECURITY SERVICES	650.00
454854	16-Apr-26	TASHIIRO CHOI & ASSOCIATES	14,000.00
454855	16-Apr-26	INSTANT JUNGLE LLC	3,575.00
454856	16-Apr-26	TURTLE ROCK CREST MAINTENANCE ASSOCIATION	3,241.33
454857	16-Apr-26	Tolerico, Steven M (Steve)	201.19
454858	16-Apr-26	Shapiro, Matthew Harris	126.16
454859	23-Apr-26	FEDEX	33.49
454860	23-Apr-26	FISHER SCIENTIFIC COMPANY, LLC	522.46
454861	23-Apr-26	JUST ENERGY SOLUTIONS INC.	106.80
454862	23-Apr-26	COMMERCIAL DOOR OF ORANGE COUNTY, INC.	8,175.44
454863	23-Apr-26	EAGLE GRAPHICS INC.	8,131.37
454864	23-Apr-26	ENVIRONMENTAL RESOURCE ASSOCIATES, INC.	358.65
454865	23-Apr-26	ENVIRONMENTAL SCIENCE ASSOCIATES	52,906.57
454866	23-Apr-26	ADS CORP.	2,781.00
454867	23-Apr-26	AGILENT TECHNOLOGIES, INC.	2,120.15
454868	23-Apr-26	CITY OF NEWPORT BEACH	3,426.50
454869	23-Apr-26	NMG GEOTECHNICAL INC	13,374.40
454870	23-Apr-26	ORANGE COUNTY FIRE PROTECTION, INC.	10,808.25
454871	23-Apr-26	ROBERTS ROOFING INC	19,357.77
454872	23-Apr-26	SERRANO WATER DISTRICT	113,137.06
454873	23-Apr-26	SOUTH COAST AIR QUALITY MANAGEMENT DISTRICT	736.57
454874	23-Apr-26	SOUTH COAST WATER CO.	120.00
454875	23-Apr-26	SOUTHERN CALIFORNIA EDISON COMPANY	424,059.53
454876	23-Apr-26	SOUTHERN COUNTIES LUBRICANTS LLC	4,832.94
454877	23-Apr-26	UNITED PARCEL SERVICE INC	74.82
454878	23-Apr-26	FRONTIER CALIFORNIA INC.	632.98
454879	23-Apr-26	WALTERS WHOLESALE ELECTRIC CO	598.59
454880	23-Apr-26	WAXIE'S ENTERPRISES, LLC, A BRADYPLUS COMPANY	1,372.67
454881	23-Apr-26	AIRGAS, INC.	1,029.07
454882	23-Apr-26	FERGUSON US HOLDINGS, INC.	5,523.50
454883	23-Apr-26	SOUTHERN CALIFORNIA GAS COMPANY	3,467.92
454884	23-Apr-26	AT&T CORP	15,811.11
454885	23-Apr-26	AT&T CORP	166.85
454886	23-Apr-26	ONESOURCE DISTRIBUTORS, LLC	2,613.47
454887	23-Apr-26	PRUDENTIAL OVERALL SUPPLY	10,824.26
454888	23-Apr-26	SEAL ANALYTICAL INC	2,248.42
454889	23-Apr-26	DELL MARKETING LP	2,014.92
454890	23-Apr-26	CHEM-TECH INTERNATIONAL INC	10,401.82
454891	23-Apr-26	LEE & RO, INC.	40,475.00
454892	23-Apr-26	PINNACLE TOWERS LLC	985.91
454893	23-Apr-26	TAIT ENVIRONMENTAL SERVICES, INC.	915.55

IRVINE RANCH WATER DISTRICT  
AP DISBURSEMENTS AND VOIDS FOR APRIL 2026

CHECK OR ELECTRONIC #	PAYMENT DATE	SUPPLIER	PAYMENT AMOUNT
454894	23-Apr-26	ENDRESS AND HAUSER INC	2,399.89
454895	23-Apr-26	DIRECTV INC	159.99
454896	23-Apr-26	THOMPSON PUMP AND	1,580.69
454897	23-Apr-26	AIR TECHNOLOGY LABORATORIES	203.50
454898	23-Apr-26	ANTHONY N. LARSEN	850.00
454899	23-Apr-26	GOVERNMENTJOBS.COM, INC.	582.06
454900	23-Apr-26	SANTA MARGARITA FORD	1,695.00
454901	23-Apr-26	COASTLINE EQUIPMENT COMPANY	673.24
454902	23-Apr-26	STETSON ENGINEERS INC.	947.50
454903	23-Apr-26	SAFETY-KLEEN SYSTEMS, INC	497.50
454904	23-Apr-26	CHEM SERVICE INC.	101.10
454905	23-Apr-26	INNOVATIVE CONSTRUCTION SOLUTIONS	160.64
454906	23-Apr-26	DAVIS FARR LLP	8,680.00
454907	23-Apr-26	VEOLIA WATER TECHNOLOGIES TREATMENT SOLUTIONS USA INC.	4,870.21
454908	23-Apr-26	ABBA TERMITE & PEST CONTROL, INC.	615.00
454909	23-Apr-26	DR. BRONSON W. HAMADA O.D. INC	225.00
454910	23-Apr-26	HOYA OPTICAL LABS OF AMERICA, INC.	216.00
454911	23-Apr-26	FERRADO BAYVIEW LLC	5,243.02
454912	23-Apr-26	THERMO FISHER SCIENTIFIC (ASHEVILLE) LLC	2,202.90
454913	23-Apr-26	HI-LINE INC	454.62
454914	23-Apr-26	NSI LAB SOLUTIONS, INC.	995.61
454915	23-Apr-26	GSRP ST SOLAR I LLC	12,566.29
454916	23-Apr-26	THOMPSON & PHIPPS INC	10,820.12
454917	23-Apr-26	AVIAT U.S., INC	5,090.27
454918	23-Apr-26	O'REILLY AUTO ENTERPRISES, LLC	177.49
454919	23-Apr-26	PAYMENTUS CORPORATION	5,536.14
454920	23-Apr-26	SPERBER COMPANIES	218,882.27
454921	23-Apr-26	MICHAEL K. NUNLEY & ASSOCIATES, LLP	20,661.50
454922	23-Apr-26	DMS FACILITY SERVICES, LLC	3,648.00
454923	23-Apr-26	STRATIFY, INC.	62,511.06
454924	23-Apr-26	CARTWRIGHT FAMILY APTS LP	261.81
454925	23-Apr-26	BPS SUPPLY GROUP	1,339.82
454926	23-Apr-26	CDW LLC	21,695.04
454927	23-Apr-26	SA GEOTECHNICAL INC.	2,122.00
454928	23-Apr-26	AN, SANGWOO	335.55
454929	23-Apr-26	BOUDREAU PIPELINE CORP	1,528.74
454930	23-Apr-26	BERKELEY ENGINEERING AND RESEARCH, INC.	3,581.46
454931	23-Apr-26	DO SUPPLY COMPANY INC	1,724.00
454932	23-Apr-26	JO-KELL, INC.	3,476.74
454933	23-Apr-26	VTX INTERMEDIATE HOLDINGS II, INC.	17,401.89
454934	23-Apr-26	BLUETRITON BRANDS INC	366.73
454935	23-Apr-26	BUAKU, ALBERTA	180.76
454936	23-Apr-26	CINTAS CORPORATION NO. 2	863.83
454937	23-Apr-26	GCP WW HOLDCO LLC	5,036.33
454938	23-Apr-26	STEVE P RADOS INC	1,860.78
454939	23-Apr-26	RIPISH, FRANCIS F	72.00
454940	23-Apr-26	FUCHIMOTO, YUSUKE	66.62

IRVINE RANCH WATER DISTRICT  
AP DISBURSEMENTS AND VOIDS FOR APRIL 2026

CHECK OR ELECTRONIC #	PAYMENT DATE	SUPPLIER	PAYMENT AMOUNT
454941	23-Apr-26	LOH, JOANNE	109.12
454942	23-Apr-26	WEIPING, YU	35.36
454943	23-Apr-26	PENSKE JR, ROGER S	175.50
454944	23-Apr-26	ELGAZAR, AHMED	53.56
454945	23-Apr-26	KHALILI, KEYAN	63.32
454946	23-Apr-26	NEHMETALLAH, NATASHA	19.36
454947	23-Apr-26	MING, XIA	28.70
454948	23-Apr-26	ZHENG, HAO	57.80
454949	23-Apr-26	SHEN, LI	21.83
454950	23-Apr-26	SHEN, JIAYING	33.33
454951	23-Apr-26	WON, YOONJIN	46.79
454952	23-Apr-26	ZHOU, ZHIYU	40.76
454953	23-Apr-26	MUNGO, RICHARD	54.07
454954	23-Apr-26	MUKAMEI, DANA	289.49
454955	23-Apr-26	KHATIB, NARIMAN	230.00
454956	23-Apr-26	LIEM, KEN	164.05
454957	23-Apr-26	GREEN, SENIA	147.94
454958	23-Apr-26	MENDOCINO FARMS	148.63
454959	23-Apr-26	16521 SCIENTIFIC WAY LLC	170.79
454960	23-Apr-26	LEVASHEFF, CHRISTINA	47.84
454961	23-Apr-26	HUANG, HAIYAN	105.00
454962	23-Apr-26	GUO, YINGPEI	78.39
454963	23-Apr-26	KHANH MONG & TRANG LE	219.15
454964	23-Apr-26	T.E ROBERTS INC	1,625.59
454965	23-Apr-26	AFSHAR, KATERA	52.17
454966	23-Apr-26	MACKAY, HEIDI	24.56
454967	23-Apr-26	RESOURCE ENVIRONMENTAL	2,308.26
454968	23-Apr-26	ELFARRA, HANANA	414.65
454969	23-Apr-26	RUTLEDGE, DARIUS	29.31
454970	23-Apr-26	LEFEBVRE, MARIE	2,759.11
454971	23-Apr-26	CHENG YANG & XIAOMEI ZANG	2,534.31
454972	23-Apr-26	CALIFORNIA DEPT OF JUSTICE	25.00
454973	23-Apr-26	INTERNATIONAL BROTHERHOOD OF ELECTRICAL WORKERS LOCAL 47	11,602.96
454974	30-Apr-26	US BANK NAT'L ASSOCIATION NORTH DAKOTA	118,536.14
454975	30-Apr-26	BANK OF NEW YORK MELLON TRUST COMPANY NA	3,300.00
454976	30-Apr-26	FEDEX	328.94
454977	30-Apr-26	FISHER SCIENTIFIC COMPANY, LLC	260.41
454978	30-Apr-26	HARPER & ASSOCIATES ENGINEERING INC	19,918.75
454979	30-Apr-26	COLONIAL LIFE & ACCIDENT INSURANCE CO.	370.32
454980	30-Apr-26	COUNTY OF ORANGE	1,359.91
454981	30-Apr-26	COUNTY OF ORANGE	616.50
454982	30-Apr-26	COX COMMUNICATIONS, INC.	3,246.99
454983	30-Apr-26	DEE JASPAR & ASSOCIATES, INC.	665.00
454984	30-Apr-26	EAST ORANGE COUNTY WATER DISTRICT	1,298.01
454985	30-Apr-26	ENVIRONMENTAL RESOURCE ASSOCIATES, INC.	3,699.04
454986	30-Apr-26	ENVIRONMENTAL SCIENCE ASSOCIATES	232.01
454987	30-Apr-26	AGILENT TECHNOLOGIES, INC.	571.67

IRVINE RANCH WATER DISTRICT  
AP DISBURSEMENTS AND VOIDS FOR APRIL 2026

CHECK OR ELECTRONIC #	PAYMENT DATE	SUPPLIER	PAYMENT AMOUNT
454988	30-Apr-26	RESTEK CORPORATION	572.15
454989	30-Apr-26	ROBERTS ROOFING INC	24,607.00
454990	30-Apr-26	SCHINDLER ELEVATOR CORPORATION	375.70
454991	30-Apr-26	SOUTHERN CALIFORNIA EDISON COMPANY	168.84
454992	30-Apr-26	SOUTHERN CALIFORNIA EDISON COMPANY	537,344.86
454993	30-Apr-26	UNITED PARCEL SERVICE INC	288.23
454994	30-Apr-26	FRONTIER CALIFORNIA INC.	167.96
454995	30-Apr-26	VERIZON WIRELESS SERVICES LLC	12,406.30
454996	30-Apr-26	WALTERS WHOLESALE ELECTRIC CO	4,912.85
454997	30-Apr-26	WAXIE'S ENTERPRISES, LLC, A BRADYPLUS COMPANY	1,071.29
454998	30-Apr-26	AIRGAS, INC.	3,401.49
454999	30-Apr-26	MC MASTER-CARR SUPPLY COMPANY	501.99
455000	30-Apr-26	GRAYBAR ELECTRIC COMPANY	8,679.11
455001	30-Apr-26	FERGUSON US HOLDINGS, INC.	2,245.00
455002	30-Apr-26	DAIOHS USA INCORPORATED	3,011.09
455003	30-Apr-26	SOUTHERN CALIFORNIA GAS COMPANY	181.09
455004	30-Apr-26	AT&T CORP	199.79
455005	30-Apr-26	AT&T CORP	67.54
455006	30-Apr-26	AT&T CORP	231.33
455007	30-Apr-26	BANK OF AMERICA	10,166.71
455008	30-Apr-26	HACH COMPANY	11,595.97
455009	30-Apr-26	SEAL ANALYTICAL INC	2,924.33
455010	30-Apr-26	DELL MARKETING LP	3,954.89
455011	30-Apr-26	TK ELEVATOR CORPORATION	200.00
455012	30-Apr-26	CHEM-TECH INTERNATIONAL INC	28,253.64
455013	30-Apr-26	MISSION COMMUNICATIONS, LLC	2,990.20
455014	30-Apr-26	TAIT ENVIRONMENTAL SERVICES, INC.	675.00
455015	30-Apr-26	DIRECTV INC	159.99
455016	30-Apr-26	TIC-RETAIL PROPERTIES	85.64
455017	30-Apr-26	RANCHO TIERRA APTS	402.03
455018	30-Apr-26	COLUMBIA COURT APTS	29.41
455019	30-Apr-26	NORTHWOOD PARK APTS	267.26
455020	30-Apr-26	RANCHO MARIPOSA APTS	19.37
455021	30-Apr-26	NORTHWOOD PLACE APTS	20.32
455022	30-Apr-26	HADRONEX, INC.	1,165.33
455023	30-Apr-26	CHEN, CHIH	18.62
455024	30-Apr-26	WILLIAM P. WARD	2,661.27
455025	30-Apr-26	THE PARKLANDS	6,431.66
455026	30-Apr-26	SAN CARLO APARTMENTS	252.34
455027	30-Apr-26	COASTLINE EQUIPMENT COMPANY	932.35
455028	30-Apr-26	SOCAL BATTERIES, INC.	6,442.96
455029	30-Apr-26	EVANTEC CORPORATION	385.58
455030	30-Apr-26	RANCHO MONTEREY APARTMENTS	2,966.59
455031	30-Apr-26	INNOVATIVE CONSTRUCTION SOLUTIONS	211,856.51
455032	30-Apr-26	KAESER COMPRESSORS, INC.	3,922.10
455033	30-Apr-26	B & H PHOTO VIDEO	12,128.90
455034	30-Apr-26	WOODBURY LANE APARTMENTS	1,730.71

IRVINE RANCH WATER DISTRICT  
AP DISBURSEMENTS AND VOIDS FOR APRIL 2026

CHECK OR ELECTRONIC #	PAYMENT DATE	SUPPLIER	PAYMENT AMOUNT
455035	30-Apr-26	PACIFIC EH&S SERVICES, INC.	2,230.40
455036	30-Apr-26	DILYTICS INC	4,080.00
455037	30-Apr-26	PIPELINE PRODUCTS, INC.	3,055.28
455038	30-Apr-26	PRONTO GYM SERVICES, INC.	360.00
455039	30-Apr-26	LAS PALMAS APTS	7,870.64
455040	30-Apr-26	UCT, LLC	1,686.26
455041	30-Apr-26	THE IRVINE COMPANY	1,847.45
455042	30-Apr-26	DR. BRONSON W. HAMADA O.D. INC	225.00
455043	30-Apr-26	SECURITAS SECURITY SERVICES USA, INC.	85,609.56
455044	30-Apr-26	SS MECHANICAL CONSTRUCTION CORP	5,200.00
455045	30-Apr-26	IBRAHIM, ROXANNE	17.57
455046	30-Apr-26	NATIONAL READY MIXED CONCRETE SALES, LLC	2,016.95
455047	30-Apr-26	UTILITY CRANE & EQUIPMENT, INC.	475.35
455048	30-Apr-26	HI-LINE INC	292.18
455049	30-Apr-26	ALLIANCE AG SERVICES, INC.	3,500.00
455050	30-Apr-26	QUICK CRETE PRODUCTS CORP.	10,763.42
455051	30-Apr-26	JOSE MARTINEZ TREE SERVICE INC.	3,000.00
455052	30-Apr-26	THOMPSON & PHIPPS INC	7,558.47
455053	30-Apr-26	VISTA PAINT CORPORATION	556.25
455054	30-Apr-26	LOZANO SMITH, LLP	4,251.50
455055	30-Apr-26	SCA OF CA, LLC	3,042.16
455056	30-Apr-26	AQUATIC INFORMATICS INC.	15,786.02
455057	30-Apr-26	REECE SUPPLY LLC	543.64
455058	30-Apr-26	SAND CANYON MEDICAL GROUP	100.00
455059	30-Apr-26	CALPINE CORPORATION	64,970.60
455060	30-Apr-26	BPS SUPPLY GROUP	1,450.60
455061	30-Apr-26	PACIFIC REAL ESTATE CONSULTANTS, INC.	20,000.00
455062	30-Apr-26	JESSICA O'MALLEY	976.81
455063	30-Apr-26	CONTINENTAL AMERICAN INSURANCE COMPANY	1,819.62
455064	30-Apr-26	PE INSTRUMENTS	857.48
455065	30-Apr-26	HUBBELL LENOIR CITY	13,522.26
455066	30-Apr-26	RINCON CONSULTANTS, INC.	33,265.91
455067	30-Apr-26	WATER SYSTEMS CONSULTING, INC.	5,416.00
455068	30-Apr-26	IRON MOUNTAIN INCORPORATED	604.06
455069	30-Apr-26	JDRS PROPERTY MANAGEMENT	103.89
455070	30-Apr-26	CENTROID INTERMEDIATE, LLC	42,992.25
455071	30-Apr-26	JO-KELL, INC.	4,250.53
455072	30-Apr-26	OPEN GOV, INC	2,910.48
455073	30-Apr-26	INSTANT JUNGLE LLC	1,356.59
455074	30-Apr-26	GONZALES, ANGELICA	99.47
455075	30-Apr-26	LIU, CHAO	62.89
455076	30-Apr-26	TADELE INVESTMENT LLC	56.04
455077	30-Apr-26	WU, BIANCA	45.65
455078	30-Apr-26	BURCH, LEE	66.43
455079	30-Apr-26	WAHLBERG, GRAHAM	58.61
455080	30-Apr-26	STOKEHOUSE	209.97
455081	30-Apr-26	NGUYEN, GINA	41.98

IRVINE RANCH WATER DISTRICT  
AP DISBURSEMENTS AND VOIDS FOR APRIL 2026

CHECK OR ELECTRONIC #	PAYMENT DATE	SUPPLIER	PAYMENT AMOUNT
455082	30-Apr-26	DE REALTY INC.	60.83
455083	30-Apr-26	SANCHEZ, GREGORY	28.90
455084	30-Apr-26	MURPHY, SHAWN J	34.75
455085	30-Apr-26	JIAO, TIANSHUI	61.16
455086	30-Apr-26	YANG, HANSON	33.48
455087	30-Apr-26	HOME EXPO FINANCIAL	22.68
455088	30-Apr-26	LI, ANG	45.25
455089	30-Apr-26	PITCHFORD, LEAH	45.59
455090	30-Apr-26	NIBLO, HILLARY H	430.55
455091	30-Apr-26	DIRAWAN, LINA	1,058.29
455092	30-Apr-26	WENTAO LI AND XIAOFAN HUANG	16.00
455093	30-Apr-26	XU, SHI YAO	54.24
455094	30-Apr-26	WU, LIN	31.75
455095	30-Apr-26	JAMES LUNDBERG AND ANGELA BISSON	221.40
455096	30-Apr-26	PARKER, MELISSA	22.21
455097	30-Apr-26	SETHI, ROHIT	61.57
455098	30-Apr-26	HARTFORD LIFE AND ACCIDENT INSURANCE COMPANY	18.74
455099	30-Apr-26	ANTHEM BLUE CROSS	425.95
455100	30-Apr-26	ISLE INC	21,780.00
455101	30-Apr-26	AMERICAN FAMILY LIFE ASSURANCE COMPANY OF COLUMBUS	3,801.54
455102	30-Apr-26	SHAOLEI REN	1,591.85
<b>SUB-TOTAL IRWD JPM CHASE CHECK AND JPM CHASE CHECK NO PRINT DISBURSEMENTS</b>			<b>9,559,668.26</b>
1010045	2-Apr-26	Do, Thu-Tam T (Tammy)	13.05
1010046	2-Apr-26	Danielson, Gregg B	29.88
1010047	2-Apr-26	Habiger, Steve Jr	59.23
1010048	2-Apr-26	Cariker, Cody J	15.23
1010049	2-Apr-26	LeGault, Daniel Anthony	250.00
1010050	2-Apr-26	Hansen, Casey	29.00
1010051	2-Apr-26	Calderon, Alfonso	16.15
1010052	2-Apr-26	Garcia, Jose (Joe)	105.00
1010053	2-Apr-26	Sanchez, Maria	62.08
1010054	2-Apr-26	Jakubas-Pufal, Dorota	27.55
1010055	2-Apr-26	Asman, David Jr.	24.07
1010056	2-Apr-26	Villella, Aaren	82.21
1010057	2-Apr-26	Salazar, Kyle	39.44
1010058	2-Apr-26	Marquez, Jesus	94.26
1010059	2-Apr-26	Greer, Matthew	55.26
1010060	2-Apr-26	Haug, Jack Philip Ryan	38.80
1010061	2-Apr-26	Tostado, Nikoli Isaiah	52.06
1010062	2-Apr-26	Stupy, Cole Austin	34.80
1010063	2-Apr-26	Estrada, Audie Nickolas	60.00
1010064	2-Apr-26	Smith, Cameron Douglas	1,799.77
1010065	2-Apr-26	Dang, Tony Tien	50.46
1010066	2-Apr-26	Mustehsan, Fizza	1,737.90
1010067	2-Apr-26	Jaramillo, Luzmila Carolina (Lucy)	1,166.94
1010068	2-Apr-26	Nearns, Eugenio Hernan (Gino)	175.00

IRVINE RANCH WATER DISTRICT  
AP DISBURSEMENTS AND VOIDS FOR APRIL 2026

CHECK OR ELECTRONIC #	PAYMENT DATE	SUPPLIER	PAYMENT AMOUNT
1010069	2-Apr-26	Aparicio, Francisco Javier	169.18
1010070	2-Apr-26	Orozco, Cinthia Beatriz	8.56
1010116	9-Apr-26	Vu, Johnny T	21.03
1010117	9-Apr-26	Perez, Rodolfo (Rudy)	119.00
1010118	9-Apr-26	Daniel, Matthew	201.69
1010119	9-Apr-26	LeGault, Daniel Anthony	16.13
1010120	9-Apr-26	Bornhoff, Mike	380.00
1010121	9-Apr-26	Garcia, Dorys Elizabeth	101.50
1010122	9-Apr-26	Valencia, Reynaldo (Rey)	31.83
1010123	9-Apr-26	Compton, Christine A	263.20
1010124	9-Apr-26	Cadena, Miguel	100.92
1010125	9-Apr-26	Ledesma, Alejandro (Alex)	326.25
1010126	9-Apr-26	Rodriguez, Jimmy	14.07
1010127	9-Apr-26	Madrid, Adam	119.78
1010128	9-Apr-26	Williams, Warren (Randy)	2,288.79
1010129	9-Apr-26	Cortez, Brian	63.37
1010130	9-Apr-26	Zamora, Victor A	51.96
1010131	9-Apr-26	Drenner, Raymond	274.00
1010132	9-Apr-26	Nguyen, Jeanny	68.31
1010133	9-Apr-26	Villella, Aaren	45.82
1010134	9-Apr-26	Madding, Joshua (Hunter)	103.10
1010135	9-Apr-26	Lee, Sabrina	60.00
1010136	9-Apr-26	Zhang, Yang	58.00
1010137	9-Apr-26	Munoz, Ruben	365.00
1010138	9-Apr-26	Scagliotti, Lucas Matthew	5.37
1010139	9-Apr-26	Ige, Brian Shigeru	154.20
1010140	9-Apr-26	Davidson, Megan Marie	34.81
1010141	9-Apr-26	Botello, Brian	147.68
1010142	9-Apr-26	Morgan, Colton Duane	251.00
1010143	9-Apr-26	Stiles, Michael Paul	13.92
1010144	9-Apr-26	Ornelas Monroy, Jose Isidro	41.47
1010210	16-Apr-26	Vu, Johnny T	21.03
1010211	16-Apr-26	Do, Thu-Tam T (Tammy)	13.05
1010212	16-Apr-26	Cariker, Cody J	15.23
1010213	16-Apr-26	Daniel, Matthew	221.12
1010214	16-Apr-26	Martinez, Jose A IV	12.83
1010215	16-Apr-26	Garcia, Alejandro (Alex)	370.00
1010216	16-Apr-26	Bornhoff, Mike	129.00
1010217	16-Apr-26	Hansen, Casey	87.00
1010218	16-Apr-26	Estrada, Robert C	75.11
1010219	16-Apr-26	Ludwig, Jason	69.60
1010220	16-Apr-26	Reed, Megan A	83.97
1010221	16-Apr-26	De Castro, Earl	69.32
1010222	16-Apr-26	Saldana Rodriguez, Cristina	114.91
1010223	16-Apr-26	Rezaee, Kaveh (Kevin)	28.73
1010224	16-Apr-26	Mares, Michael	167.00
1010225	16-Apr-26	Rios, Elias L	20.00

IRVINE RANCH WATER DISTRICT  
AP DISBURSEMENTS AND VOIDS FOR APRIL 2026

CHECK OR ELECTRONIC #	PAYMENT DATE	SUPPLIER	PAYMENT AMOUNT
1010226	16-Apr-26	Asman, David Jr.	22.04
1010227	16-Apr-26	Villalta, Jonathan	58.29
1010228	16-Apr-26	Lopez, Miguel	24.36
1010229	16-Apr-26	Rempel, Joseph A	107.74
1010230	16-Apr-26	Kuan, Abigail	16.00
1010231	16-Apr-26	Baca, Zack	28.28
1010232	16-Apr-26	Nguyen, Jeanny	45.54
1010233	16-Apr-26	Villella, Aaren	91.64
1010234	16-Apr-26	Marquez, Jesus	47.13
1010235	16-Apr-26	Lee, Sabrina	107.74
1010236	16-Apr-26	Haug, Jack Philip Ryan	152.91
1010237	16-Apr-26	Leal, Anthony E	32.48
1010238	16-Apr-26	Stupy, Cole Austin	52.20
1010239	16-Apr-26	Valdes, Jeffrey Glenn	56.12
1010240	16-Apr-26	Davidson, Megan Marie	39.67
1010241	16-Apr-26	Estrada, Audie Nickolas	99.48
1010242	16-Apr-26	Sanchez, Theodore Arthur	920.29
1010243	16-Apr-26	Aparicio, Francisco Javier	178.36
1010244	16-Apr-26	Ornelas Monroy, Jose Isidro	82.94
1010245	16-Apr-26	Passos de Menezes, Rafael	18.73
1010297	23-Apr-26	Olivolo, Eric J	37.12
1010298	23-Apr-26	Cano, Marco T	251.00
1010299	23-Apr-26	Reynoso, Pio	375.00
1010300	23-Apr-26	Cadena, Miguel	72.74
1010301	23-Apr-26	Pascual, Allan	14.79
1010302	23-Apr-26	Jakubas-Pufal, Dorota	27.55
1010303	23-Apr-26	Cervantes, Angel	58.00
1010304	23-Apr-26	Sagert, Justin	32.47
1010305	23-Apr-26	Aguilar, Alan C	31.62
1010306	23-Apr-26	Shapiro, Matthew Harris	226.16
1010307	23-Apr-26	Garibay, Erika Isela	58.88
1010308	23-Apr-26	Contreras, Joaquin	30.89
1010309	23-Apr-26	Ramirez, Eric	50.17
1010310	23-Apr-26	Mendoza, Evelyn	217.52
1010311	23-Apr-26	Contreras, Max Albert	34.80
1010312	23-Apr-26	Cahatol, Justin	347.00
1010313	23-Apr-26	McQuown, Devin Christina	219.15
1010314	23-Apr-26	Hernandez, Thomas J	55.68
1010315	23-Apr-26	Munoz, Ruben	15.95
1010316	23-Apr-26	Haug, Jack Philip Ryan	18.13
1010317	23-Apr-26	Acosta, Daniel Jr	22.31
1010318	23-Apr-26	Maldonado, Damien Michael	33.79
1010319	23-Apr-26	Ige, Brian Shigeru	250.00
1010320	23-Apr-26	Valdes, Jeffrey Glenn	56.12
1010321	23-Apr-26	Estrada, Audie Nickolas	49.74
1010370	30-Apr-26	Chaney, Michael A	21.90
1010371	30-Apr-26	Cariker, Cody J	15.23

IRVINE RANCH WATER DISTRICT  
AP DISBURSEMENTS AND VOIDS FOR APRIL 2026

CHECK OR ELECTRONIC #	PAYMENT DATE	SUPPLIER	PAYMENT AMOUNT
1010372	30-Apr-26	Daniel, Matthew	132.14
1010373	30-Apr-26	Guzman, Brenda	195.49
1010374	30-Apr-26	Ludwig, Jason	139.20
1010375	30-Apr-26	De Castro, Earl	34.66
1010376	30-Apr-26	Gates, Laura	9.14
1010377	30-Apr-26	Aguilar, Alan C	15.81
1010378	30-Apr-26	Bosley, Kelleen M	15.95
1010379	30-Apr-26	Rios, Elias L	593.79
1010380	30-Apr-26	Shapiro, Matthew Harris	63.08
1010381	30-Apr-26	Garibay, Erika Isela	29.44
1010382	30-Apr-26	Salazar, Kyle	125.00
1010383	30-Apr-26	Zhang, Yang	58.00
1010384	30-Apr-26	Scagliotti, Lucas Matthew	5.37
1010385	30-Apr-26	Greer, Matthew	18.42
1010386	30-Apr-26	Haug, Jack Philip Ryan	118.13
1010387	30-Apr-26	Gates, April	41.76
1010388	30-Apr-26	Stupy, Cole Austin	17.40
1010389	30-Apr-26	Hennequin, Mia Yoko	15.95
1010390	30-Apr-26	Aparicio, Francisco Javier	178.36
1010391	30-Apr-26	Stiles, Michael Paul	13.92
<b>SUB-TOTAL IRWD JPM CHASE ACH FOR EXPENSE REPORTS</b>			<b>20,042.64</b>
1010071	2-Apr-26	FARRELL PRINTING, INC.	2,205.74
1010072	2-Apr-26	GANAHL LUMBER CO.	2,208.36
1010073	2-Apr-26	W. W. GRAINGER, INC.	46,197.83
1010074	2-Apr-26	HAAKER EQUIPMENT COMPANY	765.27
1010075	2-Apr-26	JCI JONES CHEMICALS, INC.	38,713.13
1010076	2-Apr-26	CALIFORNIA BARRICADE RENTALS, INC.	2,192.00
1010077	2-Apr-26	GRISWOLD INDUSTRIES	9,966.88
1010078	2-Apr-26	DATA CLEAN LLC	600.00
1010079	2-Apr-26	DCSE, INC.	16,846.00
1010080	2-Apr-26	DISCOVERY SCIENCE CENTER OF ORANGE COUNTY	6,489.80
1010081	2-Apr-26	ACCUSTANDARD, INC.	140.37
1010082	2-Apr-26	AECOM TECHNICAL SERVICES, INC.	432,394.64
1010083	2-Apr-26	MUNICIPAL WATER DISTRICT OF ORANGE COUNTY	882,439.91
1010084	2-Apr-26	ORANGE COUNTY AUTO PARTS	1,654.70
1010085	2-Apr-26	PACIFIC MECHANICAL SUPPLY	5,897.70
1010086	2-Apr-26	PARKHOUSE TIRE, INC.	3,201.33
1010087	2-Apr-26	PAULUS ENGINEERING, INC.	2,769.10
1010088	2-Apr-26	PSOMAS	607.50
1010089	2-Apr-26	RINCON TRUCK CENTER INC.	829.10
1010090	2-Apr-26	WORLD TRAVEL CONSULTANTS	7,506.00
1010091	2-Apr-26	HILL BROTHERS CHEMICAL COMPANY	6,338.73
1010092	2-Apr-26	RAM AIR ENGINEERING INC	2,820.78
1010093	2-Apr-26	DAVID BALLASCH	9,357.89
1010094	2-Apr-26	BC INDUSTRIAL SUPPLY, INC	2,392.05
1010095	2-Apr-26	DOUGLAS ENVIRONMENTAL GROUP INC	1,175.00

IRVINE RANCH WATER DISTRICT  
AP DISBURSEMENTS AND VOIDS FOR APRIL 2026

CHECK OR ELECTRONIC #	PAYMENT DATE	SUPPLIER	PAYMENT AMOUNT
1010096	2-Apr-26	BORCHARD SURVEYING & MAPPING, INC.	10,990.00
1010097	2-Apr-26	QUALITY ENVIRONMENTAL CONTAINERS, INC	6,031.90
1010098	2-Apr-26	COTTONS POINT DESIGN, INC.	3,007.87
1010099	2-Apr-26	AUTOZONE PARTS, INC.	423.07
1010100	2-Apr-26	PMC-STIS INC	3,340.27
1010101	2-Apr-26	AMAZON CAPITAL SERVICES, INC.	3,735.08
1010102	2-Apr-26	LANDCARE HOLDINGS, INC.	741.42
1010103	2-Apr-26	REAL WATER CONSULTANTS INC.	24,310.00
1010104	2-Apr-26	RELIANCE STANDARD LIFE INSURANCE COMPANY	41,120.93
1010105	2-Apr-26	WEST YOST & ASSOCIATES, INC.	25,230.00
1010106	2-Apr-26	PACIFIC STAR CHEMICAL, LLC	9,777.86
1010107	2-Apr-26	MARK ENTERPRISES TECHNOLOGIES LLC	32,743.66
1010108	2-Apr-26	ACE INDUSTRIES INC	1,156.61
1010109	2-Apr-26	NEW DIMENSION GENERAL CONSTRUCTION, INC.	7,818.14
1010110	2-Apr-26	ARAG NORTH AMERICA, INC.	684.25
1010111	2-Apr-26	DELTA DENTAL OF CALIFORNIA	49,212.92
1010112	2-Apr-26	BLUE-WHITE INDUSTRIES	26,686.47
1010113	2-Apr-26	P&M HOLDING GROUP, LLP	32,082.50
1010114	2-Apr-26	ORANGE COUNTY WINWATER WORKS	12,860.05
1010115	2-Apr-26	AIR PRODUCTS AND CHEMICALS, INC.	5,597.43
1010145	9-Apr-26	FARRELL PRINTING, INC.	113.49
1010146	9-Apr-26	GM SAGER CONSTRUCTION CO, INC.	6,800.00
1010147	9-Apr-26	GANAHL LUMBER CO.	2,939.42
1010148	9-Apr-26	W. W. GRAINGER, INC.	14,581.06
1010149	9-Apr-26	HAAKER EQUIPMENT COMPANY	9,964.53
1010150	9-Apr-26	INORGANIC VENTURES INC	1,201.57
1010151	9-Apr-26	JCI JONES CHEMICALS, INC.	61,690.53
1010152	9-Apr-26	LAGUNA BEACH COUNTY WATER DISTRICT	6,606.30
1010153	9-Apr-26	CALIFORNIA BARRICADE RENTALS, INC.	15,601.50
1010154	9-Apr-26	CDW GOVERNMENT LLC	2,928.00
1010155	9-Apr-26	GRISWOLD INDUSTRIES	22,832.24
1010156	9-Apr-26	ACCUSTANDARD, INC.	1,219.28
1010157	9-Apr-26	AECOM TECHNICAL SERVICES, INC.	224,446.50
1010158	9-Apr-26	ALLIANT INSURANCE SERVICES, INC	359.00
1010159	9-Apr-26	MUNICIPAL WATER DISTRICT OF ORANGE COUNTY	5,263.50
1010160	9-Apr-26	NCL OF WISCONSIN INC	768.34
1010161	9-Apr-26	ORANGE COUNTY AUTO PARTS	2,487.83
1010162	9-Apr-26	PACIFIC MECHANICAL SUPPLY	6,070.97
1010163	9-Apr-26	PARKHOUSE TIRE, INC.	440.89
1010164	9-Apr-26	PAULUS ENGINEERING, INC.	34,739.00
1010165	9-Apr-26	S & J SUPPLY CO INC	6,132.06
1010166	9-Apr-26	TETRA TECH, INC	56,375.00
1010167	9-Apr-26	UNDERGROUND SERVICE ALERT OF SOUTHERN CALIFORNIA	8,956.24
1010168	9-Apr-26	UNIVAR SOLUTIONS USA , LLC	995.61
1010169	9-Apr-26	WATERLINE TECHNOLOGIES INC	2,720.00
1010170	9-Apr-26	HILL BROTHERS CHEMICAL COMPANY	10,598.85
1010171	9-Apr-26	RAM AIR ENGINEERING INC	1,484.69

IRVINE RANCH WATER DISTRICT  
AP DISBURSEMENTS AND VOIDS FOR APRIL 2026

CHECK OR ELECTRONIC #	PAYMENT DATE	SUPPLIER	PAYMENT AMOUNT
1010172	9-Apr-26	BRENNTAG PACIFIC INC.	3,189.00
1010173	9-Apr-26	ROSEDALE - RIO BRAVO WATER STORAGE DISTRICT	35,275.38
1010174	9-Apr-26	PAPER DEPOT DOCUMENT DESTRUCTION LLC	305.00
1010175	9-Apr-26	ZEBRON CONTRACTING INC	60,390.00
1010176	9-Apr-26	HDR ENGINEERING INC	76,078.81
1010177	9-Apr-26	RED WING SHOE STORE	8,550.44
1010178	9-Apr-26	PIPELOGIX INC	4,400.00
1010179	9-Apr-26	DUKE'S ROOT CONTROL INC	113,782.16
1010180	9-Apr-26	ENVIRONMENTAL ENGINEERING AND CONTRACTING, INC.	22,892.50
1010181	9-Apr-26	BORCHARD SURVEYING & MAPPING, INC.	2,843.00
1010182	9-Apr-26	LGC GEOTECHNICAL, INC.	4,225.00
1010183	9-Apr-26	WEST COAST SAND & GRAVEL INC.	742.19
1010184	9-Apr-26	AUTOZONE PARTS, INC.	2,303.90
1010185	9-Apr-26	LIEBERT CASSIDY WHITMORE	88.50
1010186	9-Apr-26	AMAZON CAPITAL SERVICES, INC.	6,644.05
1010187	9-Apr-26	LANDCARE HOLDINGS, INC.	1,020.94
1010188	9-Apr-26	JIG CONSULTANTS	1,227.50
1010189	9-Apr-26	CRH CALIFORNIA WATER, INC	23,927.50
1010190	9-Apr-26	WEST YOST & ASSOCIATES, INC.	95,657.72
1010191	9-Apr-26	KRONICK MOSKOVITZ TIEDEMANN & GIRARD	19,225.85
1010192	9-Apr-26	KUTAK ROCK LLP	273.00
1010193	9-Apr-26	SELECT TRENCHLESS PIPELINES INC	19,290.40
1010194	9-Apr-26	MICROSOFT CORPORATION	24.00
1010195	9-Apr-26	TANKVISIONS, INC	30.00
1010196	9-Apr-26	PACIFIC STAR CHEMICAL, LLC	3,478.90
1010197	9-Apr-26	PROTEUS CONSULTING	24,840.00
1010198	9-Apr-26	MSA SAFETY INCORPORATED	27,353.42
1010199	9-Apr-26	ALCOR SOLUTIONS, INC	41,664.00
1010200	9-Apr-26	REXEL USA, INC.	385,513.34
1010201	9-Apr-26	BIRMINGHAM FASTENER & SUPPLY INC	4,791.49
1010202	9-Apr-26	FORGE MEDIA GROUP LLC	84,800.00
1010203	9-Apr-26	ACCELERATED TECHNOLOGY LABORATORIES, LLC	14,806.00
1010204	9-Apr-26	LWP CLAIMS SOLUTIONS INC	50,887.53
1010205	9-Apr-26	ORANGE COUNTY WINWATER WORKS	8,772.44
1010206	9-Apr-26	ANIMAL PEST MANAGEMENT SERVICES, INC.	9,516.50
1010207	9-Apr-26	DRAKE TRAFFIC CONTROL SERVICES	4,594.00
1010208	9-Apr-26	CLIFTON MAXWELL II	1,040.00
1010209	9-Apr-26	AIR PRODUCTS AND CHEMICALS, INC.	755.61
1010246	16-Apr-26	FIDELITY SECURITY LIFE INSURANCE COMPANY	8,521.36
1010247	16-Apr-26	GM SAGER CONSTRUCTION CO, INC.	131,176.00
1010248	16-Apr-26	GANAHL LUMBER CO.	60.29
1010249	16-Apr-26	GCI CONSTRUCTION, INC.	115,048.07
1010250	16-Apr-26	W. W. GRAINGER, INC.	11,905.42
1010251	16-Apr-26	JCI JONES CHEMICALS, INC.	38,961.99
1010252	16-Apr-26	C WELLS PIPELINE MATERIALS, INC	3,818.66
1010253	16-Apr-26	CDW GOVERNMENT LLC	3,503.23
1010254	16-Apr-26	ORANGE COUNTY AUTO PARTS	14.90

IRVINE RANCH WATER DISTRICT  
AP DISBURSEMENTS AND VOIDS FOR APRIL 2026

CHECK OR ELECTRONIC #	PAYMENT DATE	SUPPLIER	PAYMENT AMOUNT
1010255	16-Apr-26	PACIFIC MECHANICAL SUPPLY	15,685.68
1010256	16-Apr-26	PAULUS ENGINEERING, INC.	254,471.00
1010257	16-Apr-26	PAYNE & FEARS LLP	3,915.00
1010258	16-Apr-26	PSOMAS	3,662.25
1010259	16-Apr-26	WECK ANALYTICAL ENVIRONMENT SERVICES, INC.	580.00
1010260	16-Apr-26	ALEXANDER'S CONTRACT SERVICES, INC.	150,557.81
1010261	16-Apr-26	HILL BROTHERS CHEMICAL COMPANY	11,784.83
1010262	16-Apr-26	RAM AIR ENGINEERING INC	25,696.00
1010263	16-Apr-26	MCR TECHNOLOGIES INC	14,246.12
1010264	16-Apr-26	ZEBRON CONTRACTING INC	25,190.00
1010265	16-Apr-26	HDR ENGINEERING INC	33,533.38
1010266	16-Apr-26	ORANGE COUNTY MOSQUITO AND VECTOR CONTROL DISTRICT	2,000.10
1010267	16-Apr-26	RED WING SHOE STORE	2,325.29
1010268	16-Apr-26	COUNTY OF ORANGE SANITATION DISTRICT	97,788.91
1010269	16-Apr-26	BORCHARD SURVEYING & MAPPING, INC.	1,080.00
1010270	16-Apr-26	NATURALWELL, LLC	1,625.00
1010271	16-Apr-26	COTTONS POINT DESIGN, INC.	1,340.09
1010272	16-Apr-26	WEST COAST SAND & GRAVEL INC.	743.32
1010273	16-Apr-26	THE GUERRA COMPANIES	20,799.48
1010274	16-Apr-26	LILLESTRAND LEADERSHIP CONSULTING, INC.	12,093.75
1010275	16-Apr-26	AMAZON CAPITAL SERVICES, INC.	2,906.27
1010276	16-Apr-26	LANDCARE HOLDINGS, INC.	70,985.51
1010277	16-Apr-26	MICHAEL BAKER INTERNATIONAL, INC.	3,230.55
1010278	16-Apr-26	JIG CONSULTANTS	11,083.75
1010279	16-Apr-26	WEST YOST & ASSOCIATES, INC.	14,782.66
1010280	16-Apr-26	MERRIMAC PETROLEUM, INC.	41,978.10
1010281	16-Apr-26	KUTAK ROCK LLP	1,056.00
1010282	16-Apr-26	MARK KADESH	11,092.00
1010283	16-Apr-26	RESOLUTE COMPANY	13,500.00
1010284	16-Apr-26	DOFORMS, INC	1,899.05
1010285	16-Apr-26	PACIFIC STAR CHEMICAL, LLC	16,589.64
1010286	16-Apr-26	MSA SAFETY INCORPORATED	8,075.93
1010287	16-Apr-26	ORIGIN CONSULTING LLC	16,632.00
1010288	16-Apr-26	ECO SERVICES OPERATIONS CORP.	7,368.75
1010289	16-Apr-26	NEW DIMENSION GENERAL CONSTRUCTION, INC.	8,356.00
1010290	16-Apr-26	BLUE-WHITE INDUSTRIES	5,397.16
1010291	16-Apr-26	ORANGE COUNTY WINWATER WORKS	4,313.32
1010292	16-Apr-26	DRAKE TRAFFIC CONTROL SERVICES	1,136.00
1010293	16-Apr-26	SYNAGRO WEST, LLC	51,707.93
1010294	16-Apr-26	FRESHBI LLC	3,500.00
1010295	16-Apr-26	SPRYPOINT SERVICES, INC.	184,000.00
1010296	16-Apr-26	ATLAN STORMWATER, INC.	16,378.00
1010322	23-Apr-26	W. W. GRAINGER, INC.	9,550.21
1010323	23-Apr-26	HAAKER EQUIPMENT COMPANY	4,320.06
1010324	23-Apr-26	JCI JONES CHEMICALS, INC.	54,041.64
1010325	23-Apr-26	CALIFORNIA BARRICADE RENTALS, INC.	2,071.00
1010326	23-Apr-26	CAROLLO ENGINEERS, INC	167,446.18

IRVINE RANCH WATER DISTRICT  
AP DISBURSEMENTS AND VOIDS FOR APRIL 2026

CHECK OR ELECTRONIC #	PAYMENT DATE	SUPPLIER	PAYMENT AMOUNT
1010327	23-Apr-26	CDW GOVERNMENT LLC	939.60
1010328	23-Apr-26	CITY OF IRVINE	288,288.00
1010329	23-Apr-26	GRISWOLD INDUSTRIES	6,025.40
1010330	23-Apr-26	DCSE, INC.	46,313.00
1010331	23-Apr-26	ACCUSTANDARD, INC.	166.11
1010332	23-Apr-26	ARC DOCUMENT SOLUTIONS, LLC	386.34
1010333	23-Apr-26	METTLER-TOLEDO INTERNATIONAL, INC	468.85
1010334	23-Apr-26	NEW PIG CORPORATION	801.81
1010335	23-Apr-26	ORANGE COUNTY AUTO PARTS	1,257.38
1010336	23-Apr-26	PACIFIC MECHANICAL SUPPLY	55,868.30
1010337	23-Apr-26	PARKHOUSE TIRE, INC.	2,472.14
1010338	23-Apr-26	PSOMAS	56,279.50
1010339	23-Apr-26	RINCON TRUCK CENTER INC.	697.62
1010340	23-Apr-26	TETRA TECH, INC	2,825.00
1010341	23-Apr-26	RAM AIR ENGINEERING INC	14,457.90
1010342	23-Apr-26	MCR TECHNOLOGIES INC	44,006.54
1010343	23-Apr-26	SPECTRUM PUMPING SOLUTIONS	3,792.63
1010344	23-Apr-26	RED WING SHOE STORE	5,222.37
1010345	23-Apr-26	GEOSYNTEC CONSULTANTS, INC.	30,320.37
1010346	23-Apr-26	BORCHARD SURVEYING & MAPPING, INC.	3,922.50
1010347	23-Apr-26	STANTEC CONSULTING SERVICES INC.	2,107.00
1010348	23-Apr-26	PYRO-COMM SYSTEMS INC	1,000.00
1010349	23-Apr-26	COTTONS POINT DESIGN, INC.	2,525.12
1010350	23-Apr-26	CLEAN ENERGY	11,418.13
1010351	23-Apr-26	WEST COAST SAND & GRAVEL INC.	3,846.70
1010352	23-Apr-26	VERDANTAS INC.	10,489.50
1010353	23-Apr-26	AUTOZONE PARTS, INC.	3,699.76
1010354	23-Apr-26	BIO-ACOUSTICAL ENGINEERING CORP	3,975.00
1010355	23-Apr-26	AMAZON CAPITAL SERVICES, INC.	3,279.29
1010356	23-Apr-26	SMITH SYSTEM DRIVER IMPROVEMENT INSTITUTE, INC.	5,730.70
1010357	23-Apr-26	WEST YOST & ASSOCIATES, INC.	6,699.00
1010358	23-Apr-26	MERRIMAC PETROLEUM, INC.	44,963.23
1010359	23-Apr-26	EL TORO WATER DISTRICT	49,977.00
1010360	23-Apr-26	CANNON CORPORATION	6,908.00
1010361	23-Apr-26	NEW DIMENSION GENERAL CONSTRUCTION, INC.	8,869.62
1010362	23-Apr-26	LABORATORY DATA CONSULTANTS, INC.	1,857.09
1010363	23-Apr-26	BLUE-WHITE INDUSTRIES	5,963.59
1010364	23-Apr-26	ACCELERATED TECHNOLOGY LABORATORIES, LLC	14,806.00
1010365	23-Apr-26	ORANGE COUNTY WINWATER WORKS	11,260.04
1010366	23-Apr-26	DRAKE TRAFFIC CONTROL SERVICES	13,655.50
1010367	23-Apr-26	CLIFTON MAXWELL II	4,200.00
1010368	23-Apr-26	BACKFLOW PREVENTION DEVICE INSPECTIONS INC	2,091.24
1010369	23-Apr-26	FRESHBI LLC	3,500.00
1010392	30-Apr-26	GM SAGER CONSTRUCTION CO, INC.	167,740.00
1010393	30-Apr-26	GANAHL LUMBER CO.	2,923.26
1010394	30-Apr-26	W. W. GRAINGER, INC.	4,084.82
1010395	30-Apr-26	HAAKER EQUIPMENT COMPANY	526.58

IRVINE RANCH WATER DISTRICT  
AP DISBURSEMENTS AND VOIDS FOR APRIL 2026

CHECK OR ELECTRONIC #	PAYMENT DATE	SUPPLIER	PAYMENT AMOUNT
1010396	30-Apr-26	JCI JONES CHEMICALS, INC.	69,860.38
1010397	30-Apr-26	LAGUNA BEACH COUNTY WATER DISTRICT	18,445.60
1010398	30-Apr-26	C WELLS PIPELINE MATERIALS, INC	28,363.04
1010399	30-Apr-26	CALIFORNIA BARRICADE RENTALS, INC.	84,526.50
1010400	30-Apr-26	CDW GOVERNMENT LLC	212.90
1010401	30-Apr-26	DISCOVERY SCIENCE CENTER OF ORANGE COUNTY	10,627.22
1010402	30-Apr-26	ACCUSTANDARD, INC.	178.62
1010403	30-Apr-26	AECOM TECHNICAL SERVICES, INC.	2,715.00
1010404	30-Apr-26	MUNICIPAL WATER DISTRICT OF ORANGE COUNTY	1,542,355.52
1010405	30-Apr-26	NEW PIG CORPORATION	2,489.00
1010406	30-Apr-26	NEWPORT WINDOW MAINTENANCE INC	1,382.00
1010407	30-Apr-26	ORANGE COUNTY AUTO PARTS	1,279.96
1010408	30-Apr-26	PARKHOUSE TIRE, INC.	4,083.67
1010409	30-Apr-26	QUICKEL PAVING INC	7,860.00
1010410	30-Apr-26	REACH EMPLOYEE ASSISTANCE INC	1,173.20
1010411	30-Apr-26	SWAINS ELECTRIC MOTOR SERVICE	6,396.38
1010412	30-Apr-26	WATERLINE TECHNOLOGIES INC	2,720.00
1010413	30-Apr-26	HILL BROTHERS CHEMICAL COMPANY	34,463.38
1010414	30-Apr-26	RAM AIR ENGINEERING INC	25,960.02
1010415	30-Apr-26	ZEBRON CONTRACTING INC	23,575.00
1010416	30-Apr-26	DAVID BALLASCH	6,180.54
1010417	30-Apr-26	HDR ENGINEERING INC	2,891.25
1010418	30-Apr-26	BORCHARD SURVEYING & MAPPING, INC.	2,432.50
1010419	30-Apr-26	JOHN MICHAEL COVAS	202.90
1010420	30-Apr-26	BURLINGTON SAFETY LABORATORY	385.00
1010421	30-Apr-26	COTTONS POINT DESIGN, INC.	6,272.32
1010422	30-Apr-26	JPR SYSTEMS INC.	8,616.00
1010423	30-Apr-26	VERDANTAS INC.	252.00
1010424	30-Apr-26	AUTOZONE PARTS, INC.	1,831.88
1010425	30-Apr-26	THE GUERRA COMPANIES	21,603.13
1010426	30-Apr-26	LIEBERT CASSIDY WHITMORE	798.50
1010427	30-Apr-26	AMAZON CAPITAL SERVICES, INC.	3,509.35
1010428	30-Apr-26	LANDCARE HOLDINGS, INC.	1,298.87
1010429	30-Apr-26	REAL WATER CONSULTANTS INC.	23,250.00
1010430	30-Apr-26	SMITH SYSTEM DRIVER IMPROVEMENT INSTITUTE, INC.	5,730.70
1010431	30-Apr-26	ELECTRO-CHEMICAL DEVICES, INC.	3,767.86
1010432	30-Apr-26	RELIANCE STANDARD LIFE INSURANCE COMPANY	41,902.88
1010433	30-Apr-26	WATER TREATMENT CHEMICALS INC	22,640.80
1010434	30-Apr-26	TOTAL RESOURCE MANAGEMENT, INC	15,972.10
1010435	30-Apr-26	WEST YOST & ASSOCIATES, INC.	89,434.00
1010436	30-Apr-26	ADAM'S FALCONRY SERVICE, LLC	2,040.00
1010437	30-Apr-26	MERRIMAC PETROLEUM, INC.	44,265.28
1010438	30-Apr-26	WOODARD & CURRAN INC	2,465.00
1010439	30-Apr-26	ABSOLUTE STANDARDS, INC.	190.00
1010440	30-Apr-26	PACIFIC STAR CHEMICAL, LLC	37,987.10
1010441	30-Apr-26	CANNON CORPORATION	3,971.00
1010442	30-Apr-26	CAREERS IN GOVERNMENT, INC.	3,078.00

IRVINE RANCH WATER DISTRICT  
AP DISBURSEMENTS AND VOIDS FOR APRIL 2026

CHECK OR ELECTRONIC #	PAYMENT DATE	SUPPLIER	PAYMENT AMOUNT
1010443	30-Apr-26	3SE	3,149.00
1010444	30-Apr-26	CONSERV CONSTRUCTION INC.	5,807.50
1010445	30-Apr-26	HELPMATES STAFFING SERVICES, LLC	9,651.47
1010446	30-Apr-26	ARAG NORTH AMERICA, INC.	684.25
1010447	30-Apr-26	REXEL USA, INC.	6,949.88
1010448	30-Apr-26	DELTA DENTAL OF CALIFORNIA	50,055.74
1010449	30-Apr-26	FORGE MEDIA GROUP LLC	30,000.00
1010450	30-Apr-26	STORM WATER INSPECTION & MAINTENANCE SERVICES LLC	840.00
1010451	30-Apr-26	LWP CLAIMS SOLUTIONS INC	9,605.20
1010452	30-Apr-26	P&M HOLDING GROUP, LLP	32,595.00
1010453	30-Apr-26	ORANGE COUNTY WINWATER WORKS	12,939.55
1010454	30-Apr-26	DRAKE TRAFFIC CONTROL SERVICES	3,182.00
1010455	30-Apr-26	CORNERSTONE ONDEMAND, INC.	65,205.01
1010456	30-Apr-26	THE ACE AGENCY INC.	10,975.00
<b>SUB-TOTAL IRWD JPM CHASE ACH DISBURSEMENTS</b>			<b>8,608,185.83</b>
100452	2-Apr-26	CALPERS	922,898.44
100453	9-Apr-26	CALPERS	359,922.64
100454	9-Apr-26	FRANCHISE TAX BOARD	105,760.27
100455	9-Apr-26	BANK OF AMERICA	321,506.24
100456	9-Apr-26	INTERNAL REVENUE SERVICE	312,162.75
100457	9-Apr-26	SUMITOMO MITSUI BANKING CORPORATION	266,246.00
100458	9-Apr-26	CALIFORNIA DEPARTMENT OF CHILD SUPPORT SERVICES	3,581.94
100459	9-Apr-26	EMPLOYMENT DEVELOPMENT DEPARTMENT	28,785.15
100460	9-Apr-26	EMPOWER RETIREMENT, LLC	230,926.15
100461	9-Apr-26	JP MORGAN CHASE BANK N.A.	2,893.13
100462	16-Apr-26	SUMITOMO MITSUI BANKING CORPORATION	37,241.09
100463	16-Apr-26	JP MORGAN CHASE BANK N.A.	17,739.99
100464	23-Apr-26	CALIFORNIA DEPARTMENT OF TAX AND FEE ADMINISTRATION	5,091.00
100465	23-Apr-26	CALPERS	364,151.68
100466	23-Apr-26	FRANCHISE TAX BOARD	107,918.51
100467	23-Apr-26	INTERNAL REVENUE SERVICE	317,596.43
100468	23-Apr-26	CALIFORNIA DEPARTMENT OF CHILD SUPPORT SERVICES	3,561.30
100469	23-Apr-26	EMPLOYMENT DEVELOPMENT DEPARTMENT	29,161.55
100470	23-Apr-26	GARCOA-BROWN, SONIA	25.01
100471	23-Apr-26	EMPOWER RETIREMENT, LLC	235,363.95
100472	30-Apr-26	INSPIRA FINANCIAL HEALTH, INC	72,531.13
<b>SUB-TOTAL IRWD JPM CHASE WIRE DISBURSEMENTS</b>			<b>3,745,064.35</b>
100334	30-Apr-26	WELLS FARGO BANK, N.A.	8,058.69
<b>SUB-TOTAL IRWD WELLS FARGO WIRE DISBURSEMENTS</b>			<b>8,058.69</b>
<b>SUB-TOTAL IRWD BOFA WIRE DISBURSEMENTS</b>			<b>-</b>
<b>SUB-TOTAL BOFA, WELLS FARGO CHECK, AND JPM CHASE ELECTRONIC DISBURSEMENTS</b>			<b>21,941,019.77</b>

IRVINE RANCH WATER DISTRICT  
AP DISBURSEMENTS AND VOIDS FOR APRIL 2026

CHECK OR ELECTRONIC #	PAYMENT DATE	SUPPLIER	PAYMENT AMOUNT
452748	4-Dec-25	ELFEND, ELIZABETH	36.94
452760	11-Dec-25	COLONIAL LIFE & ACCIDENT INSURANCE CO.	370.32
452958	18-Dec-25	APEX PARKS GROUP	295.25
452966	18-Dec-25	DALLWIG, SASHA	16.55
452967	18-Dec-25	CAI, CHENG	38.33
452978	18-Dec-25	CHATELLIER, SPENCER	36.60
453073	30-Dec-25	FUKASE, TETSUO	19.16
453078	30-Dec-25	REX HOUSING & MANAGEMENT LLC	441.72
453083	30-Dec-25	FULLER, JULIE	25.01
453828	12-Feb-26	LU, STACEY	101.56
453932	19-Feb-26	ATLAN STORMWATER, INC.	16,378.00
454028	26-Feb-26	ANALYTICHEM USA, INC.	101.10
454311	12-Mar-26	XUANYUAN, SHIHUI	789.36
454514	26-Mar-26	GORSKI, ANNABELLE	122.96
454799	16-Apr-26	ISLE INC	21,780.00
<b>SUB-TOTAL BOFA, WELLS FARGO CHECK, AND JPM CHASE ELECTRONIC VOIDED IN APRIL 2026</b>			<b>40,552.86</b>
<b>NET</b>			<b>21,900,466.91</b>

Note: This page is intentionally left blank.

Exhibit "E"

**MONTHLY SUMMARY OF PAYROLL ACH PAYMENTS**

**April  
2026**

	AMOUNT	VENDOR	PURPOSE
4/3/2026	1,439,501.12	J.P. MORGAN	ACH Payments for Payroll
4/17/2026	1,459,279.89	J.P. MORGAN	ACH Payments for Payroll
	<u><b>\$2,898,781.01</b></u>		

Note: This page is intentionally left blank.

Exhibit "F"

**IRWD Gov Code 53065.5 Disclosure Report**

Payment or Reimbursements for Individual charges of \$100 or more per transaction for services or product received.

01-APR-26 to 30-APR-26

NAME	CHECK NUMBER	CHECK DATE	TRANSACTION AMOUNT	ITEM DESCRIPTION	EXPENSE JUSTIFICATION
Bornhoff, Mike	1010120	9-Apr-26	129	Certification	CWEA Membership-E&I Grade IV fees reimbursement
Bornhoff, Mike	1010120	9-Apr-26	251	Membership	CWEA Membership-E&I Grade IV fees reimbursement
Bornhoff, Mike	1010216	16-Apr-26	129	Certification	CWEA - E-I IV fee reimbursement
Botello, Brian	1010141	9-Apr-26	137.03	Mileage	NASTT No Dig Show
Cahatol, Justin	1010312	23-Apr-26	347	Membership	American Water Works Association Membership Renewal Fee
Cano, Marco T	1010298	23-Apr-26	251	Membership	CWEA Membership Renewal Fee Reimbursement
Compton, Christine A	1010123	9-Apr-26	127.14	Shuttle/Taxi	Expense March 2026
Daniel, Matthew	1010118	9-Apr-26	123.38	Other(Misc)	OT Meals for 5 days
Daniel, Matthew	1010213	16-Apr-26	207.68	Other(Misc)	McFadden Dale Hardware Parts for Repairs
Drenner, Raymond	1010131	9-Apr-26	274	Certification	SWRCB WW5 fee reimbursement
Garcia, Alejandro (Alex)	1010215	16-Apr-26	251	Membership	CWEA fees reimbursement
Garcia, Alejandro (Alex)	1010215	16-Apr-26	119	Certification	CWEA fees reimbursement
Garcia, Jose (Joe)	1010052	2-Apr-26	105	Certification	Water Treatment Grade IV Renewal Fee Reimbursement
Guzman, Brenda	1010373	30-Apr-26	195.49	Other(Misc)	Retirement Party Supplies
Haug, Jack Philip Ryan	1010386	30-Apr-26	100	OT Meal	OT meal for 5 employees
Ige, Brian Shigeru	1010139	9-Apr-26	143.55	Mileage	NASTT No Dig Show
Ige, Brian Shigeru	1010319	23-Apr-26	190	Certification	D3 Certification
Jaramillo, Luzmila Carolina (Lucy)	1010067	2-Apr-26	341.64	Lodging	AMPP Annual Conference, Houston, TX March 15-19, 2026
Jaramillo, Luzmila Carolina (Lucy)	1010067	2-Apr-26	341.64	Lodging	AMPP Annual Conference, Houston, TX March 15-19, 2026
Jaramillo, Luzmila Carolina (Lucy)	1010067	2-Apr-26	341.64	Lodging	AMPP Annual Conference, Houston, TX March 15-19, 2026
Ledesma, Alejandro (Alex)	1010125	9-Apr-26	236.25	Certification	Water Treatment Grade III Renewal and CEU Course Fee Reimbursement
Lee, Sabrina	1010235	16-Apr-26	107.74	Other(Misc)	Safety Shoe Allowance
LeGault, Daniel Anthony	1010049	2-Apr-26	250	Other(Misc)	Safety Shoe Allowance
Madding, Joshua (Hunter)	1010134	9-Apr-26	103.1	Mileage	Mileage reimbursement
Mares, Michael	1010224	16-Apr-26	167	Other(Misc)	Safety Shoe Allowance
McQuown, Devin Christina	1010313	23-Apr-26	117.45	Mileage	CA-NV AWWA 2026 Water Conference of the West (WCW)
Morgan, Colton Duane	1010142	9-Apr-26	251	Membership	CWEA Association Membership Dues
Munoz, Ruben	1010137	9-Apr-26	251	Membership	CWEA Membership and CSM Grade I Renewal Reimbursement
Munoz, Ruben	1010137	9-Apr-26	114	Certification	CWEA Membership and CSM Grade I Renewal Reimbursement
Mustehsan, Fizza	1010066	2-Apr-26	1,287.10	Lodging	Esri Developer Summit and Meetings, Palm Springs, CA March 8-13, 2026
Nearns, Eugenio Hernan (Gino)	1010068	2-Apr-26	175	Membership	ESA membership renewal reimbursement
Perez, Rodolfo (Rudy)	1010117	9-Apr-26	119	Certification	CWEA Laboratory Analyst Grade 2 Certification Renewal Fees
Rempel, Joseph A	1010229	16-Apr-26	107.74	Other(Misc)	Safety Shoe Allowance
Reynoso, Pio	1010299	23-Apr-26	251	Membership	CWEA fees reimbursement
Reynoso, Pio	1010299	23-Apr-26	124	Certification	CWEA fees reimbursement
Rios, Elias L	1010379	30-Apr-26	209	Certification	CWEA Collections I fees reimbursement
Rios, Elias L	1010379	30-Apr-26	239	Membership	CWEA Collections I fees reimbursement
Saldana Rodriguez, Cristina	1010222	16-Apr-26	114.91	Other(Misc)	Safety Shoe Allowance
Sanchez, Theodore Arthur	1010242	16-Apr-26	302.31	Lodging	Water Conference of the West, San Diego, CA April 6-9, 2026
Sanchez, Theodore Arthur	1010242	16-Apr-26	302.3	Lodging	Water Conference of the West, San Diego, CA April 6-9, 2026
Sanchez, Theodore Arthur	1010242	16-Apr-26	113.68	Mileage	Water Conference of the West, San Diego, CA April 6-9, 2026
Shapiro, Matthew Harris	1010306	23-Apr-26	100	OT Meal	OT meal allowance 5 Employees

Smith, Cameron Douglas	1010064	2-Apr-26	1,313.45	Lodging	Esri Developer Summit and Meetings, Palm Springs, CA March 8-13, 2026
Tolerico, Steven M (Steve)	454857	16-Apr-26	201.19	Other(Misc)	Safety Shoe Allowance
Williams, Warren (Randy)	1010128	9-Apr-26	1,345.77	Lodging	2026 RSA Conference North America, San Francisco, CA March 23-26, 2026
Williams, Warren (Randy)	1010128	9-Apr-26	634.64	Lodging	2026 RSA Conference North America, San Francisco, CA March 23-26, 2026
			<b>Total Amount: 12,642.82</b>		

May 26, 2026  
Prepared and  
submitted by: C. Compton  
Approved by: Paul A. Cook 

## CONSENT CALENDAR

### 2026 LEGISLATIVE AND REGULATORY UPDATE

#### SUMMARY:

This report provides an update on the 2025-2026 legislative session, regulatory issues, and IRWD priorities. As legislation and regulations develop, staff will provide updates and recommendations to the Board, as appropriate.

Staff recommend the Board consider the following actions/position:

- *SB 1001 (Archuleta) – Local Agency, Corporation, Or Mutual Water Company: Personnel Access: Personal Identity Verification-Interoperable: “WATCH”.*

#### BACKGROUND:

The month of May is a busy time of year in Sacramento. The Legislature is actively hearing and amending bills. The last day for policy committees to hear fiscal bills was May 1, while May 8 was the policy committee deadline for non-fiscal bills. The last day for fiscal committees to meet and report bills introduced in their house to the Floor is May 15. In advance of that deadline, the Senate and Assembly Appropriations Committees will act on their respective Suspense Files and decide which bills to hold in committee and which to advance this year. The house of origin deadline is May 29.

A copy of the Legislative Matrix is provided as Exhibit “A”. Links to the bills discussed below are included within each discussion unless a separate exhibit is noted.

#### State Budget Update:

##### *Governor’s May Revise and Budget Projections:*

Governor Newsom will release the May Revision to his proposed Fiscal Year 2026-27 Budget the week of May 11, 2026.

Although the difference between the Governor’s revenue estimates and those of the Legislative Analyst’s Office have narrowed since the Governor’s January Proposed budget was released, there remain significant differences in the projected level of revenues and the significance of the structural budget challenges expected in the future. Staff will continue to monitor budget discussions and provide the Committee with an oral update on new developments related to the District’s state budget interests and the Governor’s May Revise.

Updates on 2026 Legislation:

*Water Affordability Legislation:*

As previously discussed with the Board, there are two bills on water affordability this legislative year. The first is AB 2739 (Soria, D-Fresno) and the second is SB 1125 (Menjivar, D-Van Nuys):

- *AB 2739 (Soria, D-Fresno) - Community Water Affordability Program:* AB 2739, which is authored by Assemblymember Esmeralda Soria and sponsored by IRWD and Rancho California, seeks to address system cost constraints and household affordability challenges simultaneously. To do this, the bill would establish a trust in the State treasury that would be funded over several decades. During that time, 45 percent of the annual appropriations to the trust would be allocated to low income water rate assistance (LIRA), 45 percent of the annual appropriations would be allocated to a new grant program at the Department of Water Resources (DWR) for grants to offset local ratepayer funds needed for water infrastructure projects, and the remaining 10 percent of the annual appropriations would be invested to ultimately provide a perpetual funding source for LIRA and the infrastructure grant program. The bill is currently on the Assembly Appropriations Suspense File and has a broad coalition of supporters; and
- *SB 1125 (Menjivar, D-San Fernando) - Water Rate Assistance Program:* SB 1125, as amended, is a reintroduction of SB 350 (Durazo, D-Los Angeles) and is sponsored by Clean Water Action, the Community Water Center, and Leadership Counsel for Justice and Accountability. If enacted, it would establish a statewide water rate assistance program at the State Board, and it would require water suppliers to participate in the statewide program and automatically enroll households in the program. Water suppliers would provide qualified low-income residential ratepayers with a flat bill credit of \$20.00 per month, and the funding for that bill credit would be provided by the State Board. The bill in print has the amendments the District negotiated with the sponsors last year to make the bill workable for water suppliers. The bill will be amended further with amendments sought of the Association of California Water Agencies (ACWA). The District currently has a “support” position on SB 1125. SB 1125 is currently on the Senate Appropriations Suspense File.

*Wildfire Related Legislation:*

Wildfires and water is again a topic of considerable discussion in the Legislature. As previously discussed with the Board, several bills that are notable and would impact water suppliers:

- *AB 2013 (Bennett, D-Ventura) - Fire Risk Areas: Water Suppliers: Emergency Preparedness Plan:* AB 2013, which is being authored by Assemblymember Steve Bennet (D-Ventura), would require water suppliers with 100 connections or more to establish an emergency preparedness plan for response to red flag warnings, extreme weather events, and other major power outages or emergencies that pose a potential threat to providing water services in moderate, high, or very high fire hazard severity zone, and encourages that that plan be developed in coordination with the county Board of Supervisors, or a county agency or department designated by the Board of Supervisors.

The bill failed passage in its policy committee and is now dead for the year. The District has an “oppose unless amended” position on AB 2013;

- *SB 1001 (Archuleta, D-Pico Rivera) - Local Agency, Corporation, Or Mutual Water Company: Personnel Access: Personal Identity Verification-Interoperable*: SB 1001 would require the Office of Emergency Services to develop a water utility worker identification program to issue identification cards, upon request, to local agency, corporation, or mutual water companies that provide water utility services. The identification cards would be used to facilitate personnel access to a restricted access area during or following a natural disaster, act of terrorism, or other similar event. Specifically, the bill would require that the credentialing would conform with the federal Personal Identity Verification standards pursuant to federal National Incident Management System guidelines. The card would be good for five years, and the requesting utility would be responsible for collecting and destroying the cards once an employee has separated from that utility. Additionally, the bill would prevent law enforcement from stopping a holder of the card from entering an area closed due to an emergency unless it is unsafe for the cardholder to do so, or their presence would interfere with disaster response.

While SB 1001 seeks to address legitimate access issues that arose during the 2025 Los Angeles fires, the bill failed, as proposed, to address existing identifications issued by local agencies and the fact that their employees are, per state law, disaster service workers. Staff working with ACWA and others to obtain amendments to SB 1001 to address those issues. Staff recommends that the Board move from an “oppose unless amended” position on SB 1001 to a “watch” position. The bill is currently on the Senate Appropriations Suspense File; and

- *SB 1153 (Caballero, D-Salinas) - Disaster preparedness: urban retail water suppliers and public water systems*: SB 1153, which is sponsored by ACWA, seeks to provide statutory clarification on public water systems and their liability during a wildfire. It also includes enhanced emergency planning provisions. The bill is in the Senate Appropriations Committee, and the District has a “support” position on SB 1153.

#### *Other Legislative Matters of Interest:*

Staff will also update the Committee, as needed, on any new developments related to legislative matters of interest to IRWD. Staff will also provide an update to the Committee on any new developments related to the following:

- *AB 1821 (Pacheco, D-Downey) - California Public Records Act: Fees and Agency Response Time*;
- *AB 2026 (Aguilar-Curry, D-Winters) - Water Diversion: Groundwater Recharge: Permit*;
- *SB 1187 (Durazo, D-Los Angeles) - Open Meetings: Majority*;
- *Data Center Related Legislation (i.e., AB 1577 (Bauer-Kahan, D-Orinda), AB 2469 (Papan, D-San Mateo), and AB 2619 (Papan))*;
- *Tribal Resources Related Legislation (i.e., AB 1881 (Ramos, D-Highland), AB 2218*

(Kalra, D-San Jose), and SB 1326 (Wahab, D- Hayward));

- Legislation related to artificial intelligence and workplace surveillance; and
- Other legislative matters of interest to IRWD.

2026 State and Regional Regulatory Update:

The following is a list of state and regional regulations and agency reports staff are monitoring, tracking, or planning to engage in over the next three to 12 months. As the next drafts of the regulations or reports are released for public review and comment, staff will engage, as appropriate. Staff will also provide an oral update to the Board on any new developments related to these regulations and other regulations of interest to the District.

The pending regulations and reports actively being tracked include:

- California Air Resources Board (CARB) Advanced Clean Fleets;
- California Underground Safety Board Proposed Rulemakings for Potholing Standard;
- Cal OSHA Occupational Safety and Health Standards Board's [Horizontal Sliding and Swinging Gates Regulation](#);
- DWR's SB 1157 Indoor Water Use Studies;
- DWR's Implementation of [SB 72 \(Caballero, 2025\)](#);
- State Board's Climate Change Resolution;
- State Board's Cross-Connection Control Policy Handbook revisions;
- State Board implementation of the [Lead and Copper Rule](#);
- State Board's [Safe and Affordable Funding for Equity and Resilience \(SAFER\) Drinking Water Program](#);
- State Board's [Development of Maximum Contaminant Levels for PFAS](#) and other associated actions on PFAS;
- State Board's Implementation of [SB 31 \(McNerney, 2025\)](#);
- South Coast AQMD's [Cumulative Impacts from Air Toxics for CEQA Projects](#);
- South Coast AQMD's Tier 4 Emergency Generator Testing Policy;
- South Coast AQMD's Proposed Rule 317.1 - Clean Air Act Nonattainment Fees for 8-Hour Ozone Standards; and
- South Coast AQMD's [Proposed Rule 1110.4, Emissions from Emergency Generators](#).

2026 Federal Legislative and Regulatory Update:

*Kern Fan Groundwater Storage Project and South Valley Project Outreach:*

IRWD's federal advocacy priority in 2026 focuses on seeking federal funding for the South Valley Conveyance and Storage Project and advocating for a reauthorization of the Small Storage Grant Program. Staff will provide an update on those efforts and the District's next steps.

*Other Federal Regulatory Updates:*

The following is a list of federal regulations and agency reports staff are monitoring, tracking, or planning to engage in over the next three to 12 months. Staff will also provide an oral update to the Committee on any new developments related to these regulations and other regulations of interest to the District. The pending regulations and reports actively being tracked include:

- Revisions to Waters of the United States Definition;
- Endangered Species Act Guidelines Updates; and
- EPA's Revised [PFAS Drinking Water Standard](#).

FISCAL IMPACTS:

Not applicable.

ENVIRONMENTAL COMPLIANCE:

Not applicable.

COMMITTEE STATUS:

This item was reviewed at the Water Resources Policy and Communications Committee on May 13, 2026.

RECOMMENDATION:

THAT THE BOARD ADOPT A "WATCH" POSITION ON SB 1001 (ARCHULETA).

LIST OF EXHIBITS:

Exhibit A – IRWD Legislative Matrix

Note: This page is intentionally left blank.

## EXHIBIT "A"

## IRWD 2024 LEGISLATIVE MATRIX

Updated: May 6, 2026

Bill No. Author	Title	IRWD Position	Summary/Effects	Status
CA AB 34 (Patterson J (R))	Large Hydroelectric Generation		Provides that under existing law, the California Renewables Portfolio Standard Program requires retail sellers and local publicly owned electric utilities to procure a minimum quantity of electricity products from eligible renewable energy resources during certain compliance periods. Provides that the provision related to the procurement of eligible renewable energy resources by local publicly owned electric utilities also applies to the compliance periods established by the Energy Commission.	01/26/2026: In ASSEMBLY. Read third time. Passed ASSEMBLY. *****To SENATE.
CA AB 35 (Alvarez (D))	Clean Air Bond Act 2024: Administrative Procedure Act	Support	Exempts the adoption of regulations needed to effectuate or implement programs of the Safe Drinking Water, Wildfire Prevention, Drought Preparedness, and Clean Air Bond Act from the requirements of the Administrative Procedure Act. Requires a state entity that receives funding to administer a competitive grant program established using the Administrative Procedure Act exemption to do certain things. Requires the Secretary of the Natural Resources Agency to post an electronic form on the Agency's Website.	01/26/2026: In ASSEMBLY. Read third time, urgency clause adopted. Passed ASSEMBLY. *****To SENATE.
CA AB 66 (Tangipa (R))	California Environmental Quality Act: Exemption: Egress		Exempts from the California Environmental Quality Act egress route projects undertaken by a public agency to improve emergency access to and evacuation from a subdivision without a secondary egress route if the State Board of Forestry and Fire Protection has recommended the creation of a secondary access to the subdivision and certain conditions are met. Requires the lead agency to hold a public meeting before determining that a project is exempt. Requires Office of Land Use and Climate Innovation notice.	07/16/2025: In SENATE Committee on NATURAL RESOURCES AND WATER: Not heard.
CA AB 69 (Calderon (D))	FAIR Plan Policy Notices and Renewals		Relates to the California FAIR Plan Association. Requires the association to provide all policyholders with a notice regarding their coverage options at least annually, including with the initial policy issuance and upon each renewal.	09/11/2025: In SENATE. Read second time and amended. Re-referred to Committee on INSURANCE.

## IRWD 2024 LEGISLATIVE MATRIX

Updated: *May 6, 2026*

Bill No. Author	Title	IRWD Position	Summary/Effects	Status
<b>CA AB 259</b> (Rubio (D))	Open Meetings: Local Agencies: Teleconferences	Support	Provides that existing law, until the specified date, authorizes the legislative body of a local agency to use alternative teleconferencing under certain conditions. Extends the alternative teleconferencing procedures until the specified date.	05/14/2025: To SENATE Committees on LOCAL GOVERNMENT and JUDICIARY.
<b>CA AB 261</b> (Quirk-Silva (D))	Fire Safety: Fire Hazard Severity Zones		Provides that existing law requires the State Fire Marshal to identify areas in the State that are not State responsibility areas as moderate, high, and very high fire hazard severity zones. Prohibits the State Fire Marshal's determination of fire hazard severity zones, in both State responsibility areas and lands that are not State responsibility areas, from being based on risk mitigation activities.	08/29/2025: In SENATE Committee on APPROPRIATIONS: Held in committee.
<b>CA AB 262</b> (Caloza (D))	California Individual Assistance Act		Enacts the California Individual Assistance Act to establish a grant program to provide financial assistance to local agencies, community-based organizations, and individuals for specified costs related to a disaster. Requires the Director of Emergency Services, in administering the California Individual Assistance Act, to prioritize recipients that are not eligible for federal funding, pursuant to specified regulations, due to the inability to meet minimum damage thresholds.	04/27/2026: Re-referred to SENATE Committee on RULES.
<b>CA AB 272</b> (Aguiar-Curry (D))	Heavy-Duty Vehicle Inspection and Maintenance Program		Provides that existing law requires the State Air Resources Board to adopt and implement a regulation for a Heavy Duty Vehicle Inspection and Maintenance Program for non gasoline heavy duty on road motor vehicles with a gross vehicle weight rating of more than a specified number of pounds. Requires, within a specified number of years following the full implementation of the program, but not later than the specified date, the State Board to provide the first of the biennial reports on its internet website.	09/02/2025: In SENATE. From third reading. To Inactive File.
<b>CA AB 300</b> (Lackey (R))	Fire Hazard Severity Zones: State Fire Marshal		Provides that existing law requires the State Fire Marshal to identify areas in the State as moderate, high, and very high fire hazard severity zones. Requires the Marshal, at least once every	08/29/2025: In SENATE Committee on APPROPRIATIONS: Held in committee.

## IRWD 2024 LEGISLATIVE MATRIX

Updated: *May 6, 2026*

Bill No. Author	Title	IRWD Position	Summary/Effects	Status
			specified number of years, to review areas in the State identified as moderate, high, and very high fire hazard severity zones, and to review lands within State responsibility areas classified as fire hazard severity zones. Requires the Marshal, at least once every certain number of years, to re-review certain areas.	
<b>CA AB 306</b> (Schultz (D))	Building Regulations: State Building Standards		Requires the State Building Standards Commission to reject a modification or change to any building standard affecting a residential unit and filed by the governing body of a city or county unless certain conditions are met, including that the commission deems those changes or modifications necessary as emergency standards to protect health and safety. Requires the commission to review certain changes or modifications within a certain period. Relates to the International Wildland-Urban Interface Code.	06/23/2025: In SENATE. Read second time and amended. Re-referred Committee on HOUSING.
<b>CA AB 311</b> (McKinnor (D))	Dwelling Units: Persons at Risk of Hness		Reinstates prior law which authorized a tenant to temporarily permit the occupancy of their dwelling unit by a person who is at risk of homelessness, with the written approval of the owner or landlord, and includes new provisions regarding occupancy. Defines person at risk of homelessness to include any person who is displaced from their residence as a result of a disaster in a disaster-stricken area in which a state of emergency has been proclaimed by the Governor.	05/07/2025: To SENATE Committee on JUDICIARY.
<b>CA AB 317</b> (Jackson (D))	California First Time Homeowner Dream Act		Exempts from the California Environmental Quality Act the new construction of a single family dwelling that meets certain conditions, including that the project contains one single family dwelling that is a specified size or less with no more than a specified number of bedrooms, the property is intended to be sold to a first time home buyer, and the lead agency determines that the developer of the project or the property owner provided sufficient legal commitments to meet the requirements of the exemption.	06/04/2025: To SENATE Committees on ENVIRONMENTAL QUALITY and HOUSING.

## IRWD 2024 LEGISLATIVE MATRIX

Updated: *May 6, 2026*

Bill No. Author	Title	IRWD Position	Summary/Effects	Status
<b>CA AB 340</b> (Ahrens (D))	Employer-Employee Relations: Confidential Communication		Prohibits a public employer from compelling a public employee, a representative of a recognized employee organization, or an exclusive representative to disclose confidential communications to a third party. Provides that this would not apply to a criminal investigation or when a public safety officer is under investigation and certain circumstances exist.	08/29/2025: In SENATE Committee on APPROPRIATIONS: Held in committee.
<b>CA AB 372</b> (Bennett (D))	Office of Emergency Services: State Matching Funds		Establishes Water Infrastructure for Wildfire Resilience Program within the OES for the distribution of state matching funds to urban wildland interface communities, as defined, in designated high fire hazard severity zones or very high fire hazard severity zones to improve water system infrastructure. Requires the OES to work in coordination with the Department of Water Resources, the State Water Resources Control Board, the Office of the State Fire Marshal, and other state entities.	09/03/2025: In SENATE. From third reading. To Inactive File.
<b>CA AB 380</b> (Gonzalez Ma (D))	Price Gouging		Provides that under existing law, upon the proclamation of an emergency, it is a misdemeanor for a person, contractor, business, or other entity to sell or offer to sell certain goods or services for a price of more than a specified percent greater than the price charged by that person immediately prior to the proclamation. Makes that misdemeanor applicable for a period of a specified number of days. Makes that misdemeanor punishable by a specified fine.	08/29/2025: In SENATE Committee on APPROPRIATIONS: Held in committee.
<b>CA AB 410</b> (Wilson (D))	Bots: Disclosure		Requires a person who uses a bot to autonomously communicate with another to ensure that the bot discloses to any person with whom the bot communicates when the bot first communicates with the person that the bot is a bot and not a human being. Authorizes the Attorney General, a district attorney, a county counsel, a city attorney, or a city prosecutor to bring a civil action to punish noncompliance.	08/29/2025: In SENATE Committee on APPROPRIATIONS: Held in committee.

## IRWD 2024 LEGISLATIVE MATRIX

Updated: *May 6, 2026*

Bill No. Author	Title	IRWD Position	Summary/Effects	Status
CA AB 426 (Dixon (R))	Impeding Emergency Response with Drone		Prohibits a person from operating or using an unmanned aerial vehicle, remote piloted aircraft, or drone at the scene of an emergency and thereby impeding firefighters, peace officers, medical personnel, military personnel, or other emergency personnel in the performance of their fire suppression, law enforcement, or emergency response duties, unless the person has a federal operational waiver. Authorizes the Attorney General or a county counsel or city attorney to bring civil action.	08/29/2025: In SENATE Committee on APPROPRIATIONS: Held in committee.
CA AB 441 (Hadwick (R))	Wildfire Prevention: Office of Wildfire Technology		Provides that existing law establishes the Office of Wildfire Technology Research and Development within the Department of Forestry and Fire Protection to study, test, and advise regarding procurement of emerging technologies and tools in order to more effectively prevent and suppress wildfires within the State. Extends the repeal date of such provisions.	06/24/2025: From SENATE Committee on GOVERNMENTAL ORGANIZATION: Do pass to Committee on NATURAL RESOURCES AND WATER.
CA AB 442 (Hadwick (R))	Z'berg-Nejedly Forest Practice Act of 1973		Provides that under the Z'berg-Nejedly Forest Practice Act of 1973, the Legislature finds and declares the policy of the State to encourage prudent and responsible forest management of nonindustrial timberlands by approving working forest management plans in advance. Provides that existing law requires the harvest area of a working forest management plan to be contained within a single hydrological area. Deletes that requirement.	01/29/2026: In ASSEMBLY. Read third time. Passed ASSEMBLY. *****To SENATE.
CA AB 501 (Papan (D))	Lawsuits, Liens, and Other Encumbrances		Prohibits a person from filing or recording, or directing another to file or record, a lawsuit, lien, or other encumbrance against any person or entity, knowing that it is false, with the intent to harass the person or entity or to influence or hinder the person in discharging their official duties if the person is a public officer or employee. Provides that a person who files a lawsuit, lien, or other encumbrance against a person or entity in violation of the prohibition is liable for a civil penalty.	01/29/2026: In ASSEMBLY. Read third time. Passed ASSEMBLY. *****To SENATE.

## IRWD 2024 LEGISLATIVE MATRIX

Updated: *May 6, 2026*

Bill No. Author	Title	IRWD Position	Summary/Effects	Status
CA AB 502 (Pellerin (D))	Elections: Deceptive Media In Advertisements		Sets forth additional requirements relating to the color and font size of the disclosure's text. Exempts an election communication from the prohibition if the content includes a disclosure stating that the communication has been generated or substantially altered using artificial intelligence. Exempts an advertisement or other election communication from these prohibitions if a reasonable person would understand that the content was satire or parody.	09/08/2025: In SENATE. From third reading. To Inactive File.
CA AB 532 (Ransom (D))	Water Rate Assistance Program		Relates to the Low Income Household Water Assistance Program. Authorizes a public urban retail water supplier to provide water rate assistance to its ratepayers. Authorizes the assistance to be provided to certain eligible ratepayers, including residential ratepayers with a certain annual income. Requires an urban retail water supplier to include in a report to State Water Resources Control Board certain information regarding its assistance program. Requires the board to conduct a survey of such suppliers.	08/29/2025: In SENATE Committee on APPROPRIATIONS: Held in committee.
CA AB 550 (Petrie-Norris (D))	The California Endangered Species Act		Relates to the authorized take of certain species by certain entities. Provides that if an at-risk species becomes listed as an endangered, threatened, or candidate species, further authorization or approval shall not be required for a take of that species, if specified conditions are met, including that the potential listing of the at-risk species was anticipated in a permit previously issued by the Department of Fish and Wildlife for incidental take caused by a renewable electrical generation facility.	07/16/2025: In SENATE Committee on NATURAL RESOURCES AND WATER: Not heard.
CA AB 596 (Ortega (D))	Elections: Ballot Disclosures		Requires the Secretary of State to create an internet website or to use other available technology to consolidate information about each state ballot measure, including a list of the top 10 contributors supporting or opposing a measure. Requires the 3 largest contributors of \$100,000 or more to all committees that	09/13/2025: In ASSEMBLY. Ordered to ASSEMBLY Unfinished Business Concurrence in Senate Amendments.

## IRWD 2024 LEGISLATIVE MATRIX

Updated: May 6, 2026

Bill No. Author	Title	IRWD Position	Summary/Effects	Status
			paid for the circulation of a statewide initiative or statewide referendum measure to also be printed on the ballot immediately following the names of the measure's supporters and opponents.	
CA AB 599 (Connolly (D))	Hazardous Waste: Classification Standards		Requires the Department of Toxic Substances Control, if the department proposes to reclassify wastes or adopt alternative management standards for regulated waste, to take all necessary and authorized steps required by law to facilitate full public notification and review of state, regional, and local facility entitlements, to enable local community input regarding the proposed changes to the classification of wastes or the alternative management standards.	06/11/2025: To SENATE Committee on ENVIRONMENTAL QUALITY.
CA AB 609 (Wicks (D))	California Environmental Quality Act: Exemption		Exempts from the requirements of the California Environmental Quality Act a housing development project that meets certain conditions relating to, for example, size, density, and location, including specific requirements for any housing on the project site located within a certain number of feet of a freeway. Requires a local government, as a condition of approval for the development, to require the development proponent to complete a certain environmental assessment regarding hazardous substance releases.	05/19/2025: In ASSEMBLY. Read third time. Passed ASSEMBLY. *****To SENATE.
CA AB 638 (Rodriguez Ce (D))	Stormwater: Uses: Irrigation		Requires the State Water Resources Control Board, by the specified date, to develop recommendations for stormwater capture and use for the irrigation of urban public lands. Requires the recommendations to address, but not be limited to, opportunities for the use of captured stormwater for irrigation to offset the use of potable water and recommendations for, among other things, pathogens and pathogen indicators and total suspended solids. Requires the board to solicit and receive written public comment.	08/29/2025: In SENATE Committee on APPROPRIATIONS: Held in committee.

## IRWD 2024 LEGISLATIVE MATRIX

Updated: *May 6, 2026*

Bill No. Author	Title	IRWD Position	Summary/Effects	Status
CA AB 643 (Wilson (D))	Climate Change: Short-Lived Climate Pollutants		Authorizes a local jurisdiction to include organic material used as a beneficial agricultural amendment towards its recovered organic waste procurement target if the material is processed at a facility authorized by the Department of Resources Recycling and Recovery using specified approved technologies, the material is licensed for end use as an agricultural fertilizer by the Department of Food and Agriculture, and the material is not derived from, or processed using, specified activities.	01/26/2026: In ASSEMBLY. Read third time. Passed ASSEMBLY. *****To SENATE.
CA AB 660 (Wilson (D))	Planning and Zoning Law: Postentitlement Phase Permits		Relates to the Planning and Zoning Law, which requires a local agency to compile lists that specify in detail the information required from any applicant for a postentitlement phase permit. Requires, if federal or State law requires review of the application by another public agency that is independent of the local agency before the agency is authorized to act on the application, certain time limits to be tolled for the application until the agency completes the review and returns the application.	08/29/2025: In SENATE Committee on APPROPRIATIONS: Held in committee.
CA AB 672 (Caloza (D))	Real Property Tax: Welfare Exemption		Provides, until a specified date, that property is within the welfare exemption if that property is owned by a community land trust, otherwise qualifying for the welfare exemption, and specified conditions are met, including that the property is being or will be developed or rehabilitated as housing. Extends the operation. Makes various conforming changes, including with respect to the lien dates for which the exemption applies.	04/30/2026: Re-referred to SENATE Committee on RULES.
CA AB 706 (Aguiar-Curry (D))	Forest Organic Residue, Energy, and Safety		Establishes the Fire Fuel Reduction Program to support sufficient procurement, transport, and beneficial use of forest biomass waste to reduce fuel for wildfires by up to a specified number of bone-dry tons of forest biomass waste per year. Establishes the FOREST and Wildfire Prevention Fund. Requires the program to grant funding priority to Bioenergy Renewable Auction Mechanism Program and Bioenergy Market Adjusting Tariff	06/11/2025: To SENATE Committees on NATURAL RESOURCES AND WATER and ENERGY, UTILITIES AND COMMUNICATIONS.

## IRWD 2024 LEGISLATIVE MATRIX

Updated: May 6, 2026

Bill No. Author	Title	IRWD Position	Summary/Effects	Status
			Program fleets in operation on or before the specified date. Appropriates funds.	
<b>CA AB 710</b> (Irwin (D))	Electricity: Advanced Metering Infrastructure		Requires the Public Utilities Commission, on or before a specified date, to require each electrical corporation to offer optional dynamic pricing tariffs. Requires the commission to require each electrical corporation, and the governing board of each local publicly owned electric utility, on or before a specified date, to analyze the feasibility of deploying advanced metering infrastructure to all customers.	01/26/2026: In ASSEMBLY. Read third time. Passed ASSEMBLY. *****To SENATE.
<b>CA AB 748</b> (Harabedian (D))	Single-Family and Multifamily Housing Units		Requires each local agency, to develop a program for the preapproval of single-family and multifamily residential housing plans, whereby the local agency accepts single-family and multifamily plan submissions for preapproval and approves or denies the preapproval applications. Requires a local agency to either approve or deny ministerially an application for a single-family or multifamily residential housing unit within 30 days if the lot meets certain conditions.	01/26/2026: In ASSEMBLY. Read third time. Passed ASSEMBLY. *****To SENATE.
<b>CA AB 758</b> (DeMaio (R))	Wildfire: Vegetation Management		Requires the Department of Forestry and Fire Protection or a local entity to conduct an assessment of all undeveloped public lands for which it is primarily responsible for preventing and suppressing fires to ensure that the public land is not a severe fire hazard. Requires this assessment to be posted on the department's and local entity's internet website. Requires all of these lands, on or before the specified date, to have firebreaks of a specified size on all borders with private property.	04/21/2025: In ASSEMBLY Committee on NATURAL RESOURCES: Failed passage.
<b>CA AB 775</b> (Fong M (D))	Behested Payments: Reporting		Provides that existing law requires certain behested payment reports to be filed by the behesting officer or member of the Public Utilities Commission with the officer's or member's agency. Requires these reports to be filed using the commission's electronic filing system for behested payment reports. Requires	08/29/2025: In SENATE Committee on APPROPRIATIONS. Held in committee and made a Two-year bill.

## IRWD 2024 LEGISLATIVE MATRIX

Updated: *May 6, 2026*

Bill No. Author	Title	IRWD Position	Summary/Effects	Status
			the filing system to issue an electronic confirmation to the filer immediately upon receipt of the report.	
<b>CA AB 846</b> (Connolly (D))	Endangered Species: Incidental Take: Wildfire		Authorizes a city, county, city and county, special district, or other local agency to submit to the Department of Fish and Wildlife a wildfire preparedness plan to conduct wildfire preparedness activities on land designated as a fire hazard severity zone that minimizes impacts to wildlife and habitat for candidate, threatened, and endangered species. Requires the department to impose a fee on a local agency for the cost of reviewing a wildfire preparedness plan submitted by that local agency.	08/29/2025: In SENATE Committee on APPROPRIATIONS: Held in committee.
<b>CA AB 859</b> (Macedo (R))	Civil Procedure: Recovery of Defense Costs		Relates to existing law whereby if the court determines that the proceeding was not brought in good faith or with reasonable cause, existing law requires the court to decide the reasonable and necessary defense costs incurred by party opposing the proceeding and to render judgment in favor of that party. Expands this provision to apply to a demurrer brought by a defendant or cross-defendant.	08/29/2025: In SENATE Committee on APPROPRIATIONS: Held in committee.
<b>CA AB 883</b> (Lowenthal (D))	Data Brokers: Personal Information		Requires the Secretary of State to provide to the agency a list of all state or local elected officials that, if available, includes each official's personal information, as specified, would require the Judicial Council to provide the agency with a list of all California judges, and would require the agency to allow elected officials or a judges to remove their information from those lists; authorizes an elected official or judge who is on a list described above, the Attorney General, a county counsel.	01/26/2026: In ASSEMBLY. Read third time. Passed ASSEMBLY. *****To SENATE.
<b>CA AB 897</b> (DeMaio (R))	Trespassing: Removal of Trespassers		Provides for the Remove Illegal Squatters from Private Property Act. Makes a person guilty of unlawful squatting when they enter upon the land or premises of another and reside on that land or premises for any period of time, knowingly acting without the	04/22/2025: In ASSEMBLY Committee on PUBLIC SAFETY: Failed passage.

## IRWD 2024 LEGISLATIVE MATRIX

Updated: *May 6, 2026*

Bill No. Author	Title	IRWD Position	Summary/Effects	Status
			knowledge or consent of the owner, rightful occupant, or an authorized representative of the owner. Requires a law enforcement agency that receives a complaint of a violation to issue a citation. Provides a means for the person to show lawful entry.	
<b>CA AB 929</b> (Connolly (D))	Sustainable Groundwater Management: Managed Wetlands		Prohibits a groundwater sustainability agency from imposing a fee upon a small community water system serving a disadvantaged community or imposing a fee for managed wetland purposes, provided the water use for each user does not increase above what was historically required. Authorizes, if a small community water system or a managed wetland extractor increases its extraction of groundwater above what was historically required, an agency to impose a fee for the usage above the historical amount.	09/10/2025: In SENATE. From third reading. To Inactive File.
<b>CA AB 942</b> (Calderon (D))	Electricity: Climate Credits		Excludes residential customers from receiving the California Climate Credit if they are not enrolled in the California Alternate Rates for Energy Program or the Family Electric Rate Assistance Program and their total electricity bills for the previous year were less than a specified amount.	08/29/2025: From SENATE Committee on APPROPRIATIONS: Do pass to Committee on RULES.
<b>CA AB 946</b> (Bryan (D))	Natural Resources: Urban Nature-based Projects		Provides that, to advance and promote environmental, conservation, and public access policies and budget actions, the Governor's office, state agencies, and the Legislature, when distributing resources, shall aspire to recognize the coequal goals and benefits of the 30x30 goal and the Outdoors for All initiative, and, to the extent practical, maximize investment in historically underserved urban communities consistent with those initiatives.	01/26/2026: In ASSEMBLY. Read third time. Passed ASSEMBLY. *****To SENATE.
<b>CA AB 950</b> (Solache (D))	Political Reform Act of 1974: Advertisements		Establishes the Billboard DISCLOSE Act. Relates to political advertisements. Provides that for certain video, print, electronic media or text message advertisements, existing law permits the name of the committee that paid for the advertisement to be	08/29/2025: In SENATE Committee on APPROPRIATIONS: Held in committee.

## IRWD 2024 LEGISLATIVE MATRIX

Updated: *May 6, 2026*

Bill No. Author	Title	IRWD Position	Summary/Effects	Status
			shortened. Clarifies that a print advertisement includes a yard sign or a billboard and an electronic media advertisement means a graphic, image, animated graphic or animated image that an online platform allows to link to a website paid for by the committee.	
<b>CA AB 956</b> (Quirk-Silva (D))	Accessory Dwelling Units: Ministerial Approval		Provides that the Planning and Zoning Law provided for the creation by local ordinance, or by ministerial approval if a local agency has not adopted an ordinance, of accessory dwelling units in areas zoned for single family or multifamily dwelling residential use in accordance with specified standards and conditions. Increases the number of detached, new construction, accessory dwelling units that a local agency is required to ministerially approve on lots with a proposed or existing single family dwelling.	06/24/2025: In SENATE Committee on HOUSING: Not heard.
<b>CA AB 990</b> (Hadwick (R))	Public Water Systems: Emergency Notification Plan		Authorizes and encourages a public water system to provide notification to water users in their preferred language when updating the emergency notification plan, if resources are available.	06/30/2025: In SENATE. From third reading. To Inactive File.
<b>CA AB 1018</b> (Bauer-Kahan (D))	Automated Decision Systems		Requires a deployer of a covered automated decision system to take certain actions, including conduct impact assessments of the covered ADS and provide deployers to whom the developer transfers the covered ADS with certain information, including a high-level summary of the results of those impact assessments.	09/13/2025: In SENATE. From third reading. To Inactive File.
<b>CA AB 1033</b> (Lackey (R))	Eminent Domain: Appraisals: Compensation		Provides that the Eminent Domain Law authorizes a public entity to exercise the power of eminent domain to acquire property for a public use. Provides that existing law requires a public entity to pay reasonable costs, not to exceed a specified amount, of an independent appraisal ordered by the owner of a property that the public entity offers to purchase under the threat of eminent	08/29/2025: In SENATE Committee on APPROPRIATIONS: Held in committee.

## IRWD 2024 LEGISLATIVE MATRIX

Updated: May 6, 2026

Bill No. Author	Title	IRWD Position	Summary/Effects	Status
			domain. Increases the limitation on the reasonable costs of an independent appraisal to a specified amount.	
<b>CA AB 1048</b> (Chen (R))	Workers Compensation		Provides that existing law requires each employer to establish a utilization review process to review and approve, modify, or deny treatment recommendations and establishes an independent medical review process to resolve disputes over a utilization review decision. Requires a request for authorization of medical services by a physician to be signed by that physician, and would authorize a request to be sent via mail, fax, or electronic methods.	01/22/2026: In SENATE. Read second time and amended. Re-referred to Committee on RULES.
<b>CA AB 1054</b> (Gipson (D))	Public Employees Retirement: Deferred Retirement Option		Establishes the Deferred Retirement Option Program as a voluntary program within the Public Employees Retirement System for employees of State Bargaining Units 5 (Highway Patrol) and 8 (Firefighters). Requires certain actions to occur, including completion of an actuarial analysis to determine the proposed program will be cost neutral, before the program becomes effective and applicable. Requires members who elect to participate in the program to meet certain requirements.	01/26/2026: In ASSEMBLY. Read third time. Passed ASSEMBLY. *****To SENATE.
<b>CA AB 1070</b> (Ward (D))	Residential Developments: Building Standards: Review		Requires the Department of Housing and Community Development to convene a working group no later than a specified date, to research and consider identifying and recommending amendments to state building standards allowing residential developments of between 3 and 10 units to be built under the requirements of the California Residential Code, as specified. Requires the department to perform a review of construction cost pressures for single-family and multifamily residential construction.	01/26/2026: In ASSEMBLY. Read third time. Passed ASSEMBLY. *****To SENATE.
<b>CA AB 1109</b> (Kalra (D))	Evidentiary Privileges: Union Agent-Represented		Establishes a privilege between a union agent and a represented employee or represented former employee to refuse to disclose any confidential communication between the employee or former employee and the union agent made while the union agent was	08/29/2025: In SENATE Committee on APPROPRIATIONS: Held in committee.

## IRWD 2024 LEGISLATIVE MATRIX

Updated: *May 6, 2026*

Bill No. Author	Title	IRWD Position	Summary/Effects	Status
			acting in the union agent's representative capacity, except as specified. Permits a represented employee or represented former employee to prevent another person from disclosing a privileged communication.	
<b>CA AB 1146</b> (Papan (D))	Water Infrastructure: Dams and Reservoirs		Prohibits the release of stored water from a reservoir owned and operated by the U.S. in the State if the release is done under false pretenses, defined as a release of water from a reservoir owned and operated by the U.S. in a manner that is knowingly, designedly, and intentionally under any false or fraudulent representation as to the purpose and intended use of the water. Authorizes the State Water Resources Control Board or the Attorney General to bring an action for injunctive relief for a violation.	08/29/2025: In SENATE Committee on APPROPRIATIONS: Held in committee.
<b>CA AB 1164</b> (Ransom (D))	Elections: Voter Bill of Rights		Provides that existing law requires a Voter Bill of Rights to be printed in the State Voter Information Guide and to be included on posters provided to each precinct. Requires the Voter Bill of Rights to inform voters that they have the right to receive a new ballot if they do not have a ballot or their ballot has been damaged.	08/29/2025: In SENATE Committee on APPROPRIATIONS: Held in committee.
<b>CA AB 1198</b> (Haney (D))	Public Works: Prevailing Wages		Provides that existing law requires that, except as specified, not less than the general prevailing rate of per diem wages, determined by the Director of Industrial Relations, be paid to workers employed on public works projects. Exempts certain housing projects from certain provisions, including, among others, projects that are restricted by deed or subject to regulatory restrictions contained in an agreement with a governmental agency or other recorded document.	01/29/2026: In ASSEMBLY. Read third time. Passed ASSEMBLY. *****To SENATE.
<b>CA AB 1206</b> (Harabedian (D))	Single Family and Multifamily Housing Units		Provides that existing law requires the planning agency of a city or county to provide an annual report to, among other entities, the Office of Land Use and Climate Innovation. Provides that	08/29/2025: In SENATE Committee on APPROPRIATIONS: Held in committee.

## IRWD 2024 LEGISLATIVE MATRIX

Updated: *May 6, 2026*

Bill No. Author	Title	IRWD Position	Summary/Effects	Status
			existing law requires the annual report to include, among other things, the city's or county's progress in meeting its share of regional housing needs. Requires, for large and small jurisdictions, the agency to include the number of units of residential housing that are approved using a preapproved housing plan.	
<b>CA AB 1227</b> (Ellis (R))	Wildfire Safety: Fuels Reduction Projects		Requires the lead agency to hold a noticed public meeting to hear and respond to public comments before determining that a project is exempt and would require the lead agency to provide notice of the public meeting on its internet website at least 30 days before the public meeting. Requires the lead agency, if it determines that a project is not subject to CEQA and approves or carries out that project, to file a notice of exemption with the Office of Land Use and Climate Innovation.	08/29/2025: In SENATE Committee on APPROPRIATIONS: Held in committee.
<b>CA AB 1234</b> (Ortega (D))	Employment: Nonpayment of Wages: Complaints		Provides that existing law authorizes the Labor Commissioner to investigate employee complaints and to provide for a hearing in any action to recover wages, penalties, and other demands for compensation. Authorizes the Labor Commissioner, in an order, decision, or award granted pursuant to specified provisions, to impose an administrative fee of up to a specified percent of the award. Requires the administrative fee to be deposited into the Wage Recovery Fund.	09/03/2025: In SENATE. From third reading. To Inactive File.
<b>CA AB 1240</b> (Lee (D))	Single Family Residential Real Property: Corporate		Prohibits a business entity that has an interest in more than a specified number of single family residential properties from purchasing, acquiring, or otherwise obtaining an ownership interest in another single family residential property and subsequently leasing the property. Authorizes the Attorney General to bring a civil action for a violation of these provisions. Requires a court in a civil action in which the Attorney General prevails to order specified relief, including civil penalties.	06/19/2025: In SENATE. Read second time and amended. Re-referred to Committee on JUDICIARY.

## IRWD 2024 LEGISLATIVE MATRIX

Updated: *May 6, 2026*

Bill No. Author	Title	IRWD Position	Summary/Effects	Status
CA AB 1242 (Nguyen (D))	Language Access		Relates to the Dymally-Alatorre Bilingual Services Act. Revises the definition of substantial number of non-English-speaking people to include the higher of either the people served by or eligible to be served by a State agency. Requires the State Health and Human Services Agency to designate a Language Access Director to ensure individuals with limited English proficiency and individuals who are deaf or hard of hearing have meaningful access to government programs and services.	08/29/2025: In SENATE Committee on APPROPRIATIONS. Held in committee and made a Two-year bill.
CA AB 1276 (Carrillo J (D))	Housing Developments: Ordinances		Relates to the Permit Streamlining Act. Provides that a housing development project or emergency shelter shall be deemed consistent, compliant, and in conformity with an applicable plan, program, policy, ordinance, standard, requirement, or other similar provision adopted or implemented by a public agency if there is substantial evidence that would allow a reasonable person to conclude that the project or emergency shelter is consistent, compliant, or in conformity, with specified exceptions.	08/29/2025: In SENATE Committee on APPROPRIATIONS: Held in committee.
CA AB 1294 (Haney (D))	Planning and Zoning: Housing Development		Requires that an application for a housing entitlement be deemed complete upon payment of the permit processing fees and upon completing specified requirements except with respect to applications for housing development projects located in certain jurisdictions. Adds a violation of the housing entitlement application requirements to the list of laws that, when violated, require the department to notify the jurisdiction and authorize the Attorney General to bring an action to enforce state law.	04/28/2026: In SENATE. Read second time and amended. Re-referred to Committee on LOCAL GOVERNMENT.
CA AB 1331 (Elhawary (D))	Workplace Surveillance		Limits the use of workplace surveillance tools by employers, including by prohibiting an employer from monitoring or surveilling workers in employee-only, employer-designated areas. Provides workers with the right to leave behind workplace surveillance tools that are on their person or in their possession during off-duty hours. Prohibits a worker from removing or physically tampering with any component of a workplace	09/13/2025: In SENATE. From third reading. To Inactive File.

## IRWD 2024 LEGISLATIVE MATRIX

Updated: *May 6, 2026*

Bill No. Author	Title	IRWD Position	Summary/Effects	Status
			surveillance tool that is part of or embedded in employer equipment or vehicles.	
<b>CA AB 1337</b> (Ward (D))	Information Practices Act of 1977		Provides that the Information Practices Act of 1977 prescribes a set of requirements, prohibitions, and remedies applicable to agencies with regard to their collection, storage, and disclosure of personal information. Prohibits an agency from using records containing personal information for any purpose or purposes other than the purpose or purposes for which that personal information was collected, except as required or authorized by State law.	04/27/2026: Re-referred to SENATE Committee on RULES.
<b>CA AB 1413</b> (Papan (D))	Sustainable Groundwater Management Act: Groundwater		Provides that existing law requires a groundwater sustainability agency to evaluate its groundwater sustainability plan periodically. Requires a groundwater sustainability agency to, at least once every 7 years, review, and update if appropriate, its sustainable yield to ensure that the sustainable yield is based on the best available information and best available science, as defined, and will achieve sustainable groundwater management.	09/09/2025: In SENATE. From third reading. To Inactive File.
<b>CA AB 1421</b> (Wilson (D))	Vehicles: Road Usage Charge Technical Advisory		Requires the commission, in consultation with the Transportation Agency, to consolidate and prepare research and recommendations related to a road user charge or a mileage-based fee system. Requires the commission to submit a report, as specified, on the research and recommendations described above to the appropriate policy and fiscal committees of the Legislature by no later than January 1, 2027.	01/29/2026: In ASSEMBLY. Read third time. Passed ASSEMBLY. *****To SENATE.
<b>CA AB 1439</b> (Garcia Ro (D))	Public Retirement Systems: Development Projects: Labor		Requires the boards of Public Employees' Retirement System (PERS) and the State Teachers' Retirement System (STRS) to contract with the University of California Labor Centers to conduct an independent study to determine the impacts on public employee retirement funds of prohibiting the board of a public pension or retirement system, as defined, from investing in	01/29/2026: In ASSEMBLY. Read third time. Passed ASSEMBLY. *****To SENATE.

## IRWD 2024 LEGISLATIVE MATRIX

Updated: *May 6, 2026*

Bill No. Author	Title	IRWD Position	Summary/Effects	Status
			development projects in California that do not provide labor standards protections for workers.	
CA AB 1447 (Gipson (D))	Unclaimed Property: Notice		Relates to the Unclaimed Property Law. Provides that existing law requires the Controller to mail a notice to each person who appears to be entitled to property valued at a specified dollar amount or more and whose address is listed in a specified report or is obtained from the Franchise Tax Board. Specifies that if the address listed in the report is not a valid deliverable address, but the Controller identifies a corrected valid address, the Controller must mail the notice to the corrected address.	08/18/2025: In ASSEMBLY. Ordered returned to SENATE. *****To SENATE.
CA AB 1457 (Bryan (D))	Wildfires: Training: Defensible Space: Inspections		Provides that existing law requires the Director of Forestry and Fire Protection to establish a statewide program to allow certain persons and entities that have completed specific training developed by the Department of Forestry and Fire Protection to support certain efforts. Extends the operation of the program indefinitely. Requires the training to include training consistent with the Home Ignition Zone/Defensible Space Inspector course plan.	09/08/2025: In SENATE. From third reading. To Inactive File.
CA AB 1538 (Krell (D))	Crimes: Corruption		Makes it a crime for an elected or appointed official, under color of authority, to retaliate or exert political retribution against a person for exercising a constitutionally protected right. Makes a violation of this crime punishable by forfeiture of office. Specifies that these provisions do not apply to the hiring or personnel decisions of elected or appointed officials that are relative to an employee or prospective employee of that elected or appointed official.	04/08/2026: In ASSEMBLY Committee on APPROPRIATIONS: To Suspense File.
CA AB 1542 (Ward (D))	Sensitive Personal Information		Prohibits under the California Consumer Privacy Act of 2018 (CCPA), a business, service provider, or contractor from selling or sharing sensitive personal information to a third party.	05/06/2026: In ASSEMBLY Committee on APPROPRIATIONS: To Suspense File.

## IRWD 2024 LEGISLATIVE MATRIX

Updated: May 6, 2026

Bill No. Author	Title	IRWD Position	Summary/Effects	Status
CA AB 1553 (Connolly (D))	California Environmental Quality Act: Notice: Direct		Provides that the California Environmental Quality Act requires a lead agency that is preparing an environmental impact report, a negative declaration, or making other determinations, to provide public notice of that fact within a reasonable period of time. Authorizes a lead agency to satisfy specified direct mailing requirements by electronic mail if the recipient affirmatively requested to receive notice by electronic mail.	03/16/2026: In ASSEMBLY. Read second time and amended. Re-referred to Committee on NATURAL RESOURCES.
CA AB 1554 (Calderon (D))	Disasters Data		Provides that existing law establishes the California Earthquake Authority (CEA), administered under the authority of the Insurance Commissioner, to transact insurance in this state as necessary to sell policies of basic residential earthquake insurance. Requires the CEA to provide the annual report to the Senate Committee on Insurance and the Assembly Committee on Insurance. Specifies that the certified examination and verification report be posted on the CEA's internet website.	04/30/2026: In ASSEMBLY. Read second time and amended. Re-referred to Committee on APPROPRIATIONS.
CA AB 1560 (Tangipa (R))	Lobbyist Certification		Prohibit a person who has been convicted of a crime of public corruption, from serving as a lobbyist for 12 years following the date of the conviction. Prohibits the Secretary of State from accepting a lobbying certification from such a person, and it would also void an existing lobbying certification in the event of such a conviction. Requires a lobbying certification to include a statement that the applicant has not been convicted of a crime of public corruption within the previous 12 years.	04/23/2026: In ASSEMBLY. Read third time and amended. To third reading.
CA AB 1563 (Gabriel (D))	Budget Act of 2026		Relates to appropriations for the support of state government for the 2026-27 fiscal year.	04/06/2026: To ASSEMBLY Committee on BUDGET.
CA AB 1564 (Ahrens (D))	Employer-employee relations: Confidential Communication		Prohibits a public employer from questioning a public employee, a representative of a recognized employee organization, or an exclusive representative regarding communications made in confidence between an employee and an employee representative	05/06/2026: In ASSEMBLY Committee on APPROPRIATIONS: To Suspend File.

## IRWD 2024 LEGISLATIVE MATRIX

Updated: *May 6, 2026*

Bill No. Author	Title	IRWD Position	Summary/Effects	Status
			in connection with representation relating to any matter within the scope of the recognized employee organization's representation.	
<b>CA AB 1573</b> (Bryan (D))	Land Use: Housing Elements: Target Population		Provides that the Planning and Zoning Law requires a city or county to adopt a general plan for land use development that includes, among other things, a housing element containing certain information, including an analysis of its special housing, emergency shelter, and supportive housing needs. Provides that the definition of the term target population for the purposes of requirements applicable to the housing element may include victims of domestic violence, sexual assault, and human trafficking.	05/04/2026: In ASSEMBLY. Read third time. Passed ASSEMBLY. *****To SENATE.
<b>CA AB 1576</b> (Ortega (D))	Workers' Compensation: Subsequent Injuries Payments		Establishes a workers' compensation system, administered by the Administrative Director of the Division of Workers' Compensation, to compensate an employee for injuries sustained in the course of employment. Provides certain methods for determining workers' compensation benefits payable to a worker or the worker's dependents for purposes of permanent total disability or permanent partial disability that include a determination of the percentage of permanent disability incurred.	05/06/2026: In ASSEMBLY Committee on APPROPRIATIONS: To Suspense File.
<b>CA AB 1577</b> (Bauer-Kahan (D))	Data Centers: Reporting		Requires the Energy Commission to establish a process for the owner of a data center to submit specified information to the commission, including, among other information, the data center's location and size, the data center's power usage effectiveness and the quantity of fuel consumed by onsite generators or other fuel-based energy systems.	05/06/2026: In ASSEMBLY Committee on APPROPRIATIONS: To Suspense File.
<b>CA AB 1578</b> (Jackson (D))	State and Local Officials: Sexual Harassment Training		Requires, for an employer that is a State agency or local agency, that certain training and education include, as a component of the training and education for elected officials, anti hate speech training. Specifies that a State official or local official who serves more than one State agency or local agency only be required to	05/06/2026: In ASSEMBLY Committee on APPROPRIATIONS: To Suspense File.

## IRWD 2024 LEGISLATIVE MATRIX

Updated: May 6, 2026

Bill No. Author	Title	IRWD Position	Summary/Effects	Status
			receive the specified training once every specified number of years without regard to the number of State agencies or local agencies the official serves.	
<b>CA AB 1609</b> (Zbur (D))	Customer Service Chatbots		Prohibits a large private business from representing that a customer service chatbot is a human. Requires the large private business to provide certain disclosures if a reasonable person interacting with the chatbot would be misled to believe they are interacting with a human. Requires a large private business to provide customers with human customer service support and communications within a specified number of minutes of requesting human customer service.	05/06/2026: In ASSEMBLY Committee on APPROPRIATIONS: To Suspense File.
<b>CA AB 1610</b> (Ransom (D))	Elections: Notice		Requires a county elections official to take the specified steps to provide notice to a voter when U.S. Postal Service data indicates a voter has a mailing address that is different from the voters residence address and the mailing address is no longer valid. Provides that if a new mailing address is available via change of address data, the elections official would be required to update the voters registration record with the new mailing address and send a forwardable notice to the new address to confirm.	05/06/2026: In ASSEMBLY Committee on APPROPRIATIONS: To Suspense File.
<b>CA AB 1617</b> (Alanis (R))	Reporting of Household Hazardous Waste		Relates to household hazardous waste reporting.	04/16/2026: In ASSEMBLY. Read third time. Passed ASSEMBLY. *****To SENATE.
<b>CA AB 1621</b> (Wilson (D))	Planning and Zoning Law: Postentitlement Phase Permits		Prohibits a local agency or state agency from requiring or requesting more than 2 plan check and specification reviews in connection with an application for a building permit, as part of its review, except as specified. Authorizes a local agency or state agency to deny an application that is not compliant with the permit standards following 2 plan check and specification reviews.	04/27/2026: In ASSEMBLY. Read third time. Passed ASSEMBLY. *****To SENATE.

## IRWD 2024 LEGISLATIVE MATRIX

Updated: *May 6, 2026*

Bill No. Author	Title	IRWD Position	Summary/Effects	Status
CA AB 1624 (Zbur (D))	Public Lands Protection Act		Enacts the Public Lands Protection Act, upon transfer to any private or nonfederal entity of a parcel of land located within the state that is owned by the United States government on or after January 1, 2025, and that has been designated in an adopted general plan or zoning ordinance as open space, public land, resource conservation, or an equivalent conservation-oriented designation, immediately subject that parcel to the zoning designation and associated state and local restrictions.	04/15/2026: In ASSEMBLY Committee on LOCAL GOVERNMENT: Not heard.
CA AB 1630 (Caloza (D))	Meet and Confer: Observation		Authorizes an exclusive representative, in their discretion, to invite one or more members of a bargaining unit to remotely and passively observe a session held for the purpose of a meet and confer on a memorandum of understanding. The bill would prohibit, absent an agreement of the parties, a member of a bargaining unit observing a session pursuant to these provisions from receiving released or reassigned time or compensation to observe a session.	05/06/2026: In ASSEMBLY Committee on APPROPRIATIONS: To Suspend File.
CA AB 1632 (Johnson N (R))	Trespass		Provides that existing law requires the owner, the owners agent, or the person in lawful possession to make a separate request to a peace officer on each occasion when the peace officers assistance in dealing with a trespass is requested. Provides that existing law authorizes a single request for assistance to be made and submitted electronically, in a notarized form provided by the law enforcement agency, to a peace officer. Removes the requirement that the submitted form be notarized.	03/23/2026: In ASSEMBLY. Read second time. To third reading.
CA AB 1642 (Harabedian (D))	Wildfires: Contamination Standards		Requires the Department of Toxic Substances Control to adopt, no later than July 1, 2027, emergency regulations specifying the science-informed, health-based standards for investigation, environmental testing, and clearance, to guide the removal of lead and asbestos inside and outside of homes, schools, workplaces, and other structures in residential areas after a wildfire.	04/08/2026: In ASSEMBLY Committee on APPROPRIATIONS: To Suspend File.

## IRWD 2024 LEGISLATIVE MATRIX

Updated: May 6, 2026

Bill No. Author	Title	IRWD Position	Summary/Effects	Status
<b>CA AB 1652</b> (Patterson J (R))	State Agencies: Regulations and Legislation		Prohibits an elective or appointive officer of a state agency acting in their official capacity from entering into, or requesting that another party enter into, a nondisclosure agreement relating to the drafting, negotiation, or discussion of a proposed regulation or legislation.	04/16/2026: In ASSEMBLY. Read third time. Passed ASSEMBLY. *****To SENATE.
<b>CA AB 1664</b> (Jackson (D))	Elections: Law Enforcement Investigations of Elections		Requires a local agency, political subdivision, or elections official to provide written notice to the Secretary of State and the Attorney General no later than one business day after becoming aware of any warrant, subpoena, or active law enforcement investigation pertaining to any election records or voting systems under their custody or control. Repeals certain provisions on the specified date.	05/06/2026: From ASSEMBLY Committee on APPROPRIATIONS: Do pass as amended.
<b>CA AB 1677</b> (Boerner (D))	Public Utilities: Electrical and Gas Corporations		Requires the Public Utilities Commission to require an electrical corporation or gas corporation proposing to change a rate, or to alter a classification, contract, practice, or rule so as to result in a new rate based on its request for return on invested capital, to include in its proposal certain studies. Prohibits the commission from establishing an authorized return on equity for an electrical corporation or gas corporation that exceeds the rate on federally issued long term debt by a certain amount.	03/19/2026: In ASSEMBLY. Read second time and amended. Re-referred to Committee on UTILITIES AND ENERGY.
<b>CA AB 1680</b> (Calderon (D))	California FAIR Plan Association		Requires the CA FAIR Plan Association to take corrective actions to correct violations of applicable statutes, regulations, statutory accounting principles, or other applicable rules identified in a report of examination or other operational report. Sets other civil penalty amounts for violations of provisions relative to the association as not to exceed \$10,000 for each act in violation or not to exceed \$20,000 if the act was willful, and would require the commissioner to impose those penalties.	04/29/2026: In ASSEMBLY Committee on APPROPRIATIONS: To Suspense File.

**IRWD 2024 LEGISLATIVE MATRIX**

Updated: *May 6, 2026*

Bill No. Author	Title	IRWD Position	Summary/Effects	Status
CA AB 1710 (Carrillo J (D))	Housing Developments: Ordinances, Policies, Standards		Includes in the definition of ordinances, policies, and standards under the Housing Accountability Act materials requirements, post-entitlement permit standards, and any rules, regulations, determinations, and other requirements adopted or implemented by other public agencies.	04/29/2026: In ASSEMBLY Committee on APPROPRIATIONS: To Suspend File.
CA AB 1712 (Pacheco (D))	City of Santa Fe Springs: Sale of Water Utility		Authorizes the City of Santa Fe Springs to sell its public utility for furnishing water service for the purpose of consolidating its public water system with another public water system pursuant to specified procedures if certain requirements are met. Requires the city to consider oral and written protests and prohibits the city from selling the public utility for a certain period if a specified percent of interested persons protest the sale. Makes legislative findings and declarations.	05/06/2026: From ASSEMBLY Committee on APPROPRIATIONS: Do pass.
CA AB 1722 (Hadwick (R))	California Endangered Species Act: Take Prohibition		Requires a person who committed a take, or an attempted take, of a species listed pursuant to the California Endangered Species Act under certain circumstances to notify the Department of Fish and Wildlife within a specified number of hours after the take.	05/06/2026: From ASSEMBLY Committee on APPROPRIATIONS: Do pass.
CA AB 1727 (Ta (R))	Crimes: Theft of DNA		Requires all local law enforcement agencies in the state to report to the Attorney General starting July 1, 2027, and annually thereafter, the number of reports filed in the past year on the theft of deoxyribonucleic acid (DNA) and the current status of those cases. Requires the Attorney General to, on or before January 1, 2028, report to the Legislature, and post on its internet website, the number of police reports filed on the theft of DNA and the current status of those cases.	04/23/2026: In ASSEMBLY. Read second time and amended. Re-referred to Committee on APPROPRIATIONS.
CA AB 1732 (Alvarez (D))	California Environmental Quality Act: Exemption		Provides that the California Environmental Quality Act (CEQA) requires a lead agency, as defined, to prepare, or cause to be prepared, and certify the completion of, an environmental impact report on a project that it proposes to carry out or approve that may have a significant effect on the environment or to adopt a	04/27/2026: In ASSEMBLY. Read second time and amended. Re-referred to Committee on APPROPRIATIONS.

## IRWD 2024 LEGISLATIVE MATRIX

Updated: May 6, 2026

Bill No. Author	Title	IRWD Position	Summary/Effects	Status
			negative declaration if it finds that the project will not have that effect. CEQA also requires a lead agency to prepare a mitigated negative declaration for a project.	
<b>CA AB 1736</b> (Pellerin (D))	Political Reform Act of 1974: Lobbyist Employers		Relates to existing law which prohibits a lobbyist or lobbying firm from attempting to create a fictitious appearance of public favor or disfavor of any proposed legislative or administrative action or to cause any communication to be sent to any elected state officer, legislative official, agency official, or state candidate in the name of any fictitious person or in the name of any real person, except with the consent of the real person. Extends this prohibition to lobbyist employers.	04/23/2026: In ASSEMBLY. Read third time. Passed ASSEMBLY. *****To SENATE.
<b>CA AB 1772</b> (Papan (D))	Fish and Wildlife: Invasive Mussels		Authorizes the Director of Fish and Wildlife or the director's designee to engage in various enforcement activities, including ordering the areas in conveyance that contain water be drained, dried, or decontaminated, as provided. Prohibits a conveyance from being launched until a specified drying period has completed, as provided. Imposes a state-mandated local program by expanding the scope of a crime. Authorizes the department to decontaminate or order decontamination of a conveyance.	04/27/2026: In ASSEMBLY. Read second time and amended. Re-referred to Committee on APPROPRIATIONS.
<b>CA AB 1777</b> (Garcia Ro (D))	Air Pollution: Indirect Sources		Authorizes the State Air Resources Board, if necessary to carry out their duty to achieve ambient air quality standards, to adopt regulations to reduce or mitigate emissions from indirect sources of pollution.	04/08/2026: In ASSEMBLY Committee on APPROPRIATIONS: To Suspense File.
<b>CA AB 1786</b> (Harabedian (D))	Public Contracts: Best Value Construction Contracting		Provides that existing law establishes a program to allow counties to select a bidder on the basis of best value for construction projects in excess of a specified amount. Authorizes a county, city, or the San Gabriel Valley Council of Governments to select a bidder on the basis of best value for construction projects in excess of a specified amount. Expands the crime of perjury by extending the operation of the program and expanding the	05/06/2026: From ASSEMBLY Committee on APPROPRIATIONS: Do pass.

## IRWD 2024 LEGISLATIVE MATRIX

Updated: *May 6, 2026*

Bill No. Author	Title	IRWD Position	Summary/Effects	Status
			program to cities and the San Gabriel Valley Council of Governments.	
<b>CA AB 1821</b> (Pacheco (D))	California Public Records Act: Agency Response Time		Provides that the State Public Records Act requires each State or local agency, upon a request for a copy of records, to make the records promptly available to any person upon payment of fees covering direct costs of duplication, or a statutory fee if applicable. Requires each agency to determine whether the request seeks copies of disclosable public records in possession of the agency and to promptly notify the person within a specified number of business days of a request for a copy of records.	04/23/2026: In ASSEMBLY. Read second time. To third reading.
<b>CA AB 1823</b> (Jackson (D))	State Government: State Government Strategic Planning		Requires every State agency or department subject to the Governors authority to take specified actions in regard to any strategic plan to more effectively advance racial equity and to undertake a racial equity analysis before implementing any budget or before any regulation takes effect by the agencies or departments diversity, equity, and inclusion officer or comparable position.	04/22/2026: In ASSEMBLY Committee on APPROPRIATIONS: To Suspend File.
<b>CA AB 1834</b> (Patel (D))	Subdivisions: Tentative and Final Map: Exceptions		Provides that the Subdivision Map Act requires a tentative and final map for specified subdivisions, including subdivisions of 5 or more parcels or condominiums, with certain exceptions. Expands an exception to include land that comprises part of a tract of land zoned for mixed use development, inclusive of mixed use developments containing residential uses, and that satisfies certain requirements.	04/09/2026: In ASSEMBLY. Read third time. Passed ASSEMBLY. *****To SENATE.
<b>CA AB 1838</b> (Berman (D))	Public Contracts: Local Agencies: Bidders		Requires a contractor, as a condition of submitting a bid to a local agency for a public works contract, to fully disclose any history of wage and hour violations and provide supporting documentation. Authorizes a contractor that fails to provide the required disclosures and supporting materials to be disqualified from the bid.	04/20/2026: In ASSEMBLY. Read third time. Passed ASSEMBLY. *****To SENATE.

## IRWD 2024 LEGISLATIVE MATRIX

Updated: May 6, 2026

Bill No. Author	Title	IRWD Position	Summary/Effects	Status
<b>CA AB 1840</b> (Sanchez (R))	Political Reform Act of 1974: Prediction Market		Prohibits specified officials, employees, and lobbyists from engaging in transactions involving prediction market contracts, as defined, if before or at the time of the transaction, the specified individual possesses, or it is reasonably foreseeable the specified individual may obtain in the course of their official duties, material nonpublic information relating to the transaction.	02/23/2026: To ASSEMBLY Committee on ELECTIONS.
<b>CA AB 1849</b> (Papan (D))	Decarbonized Gaseous Fuels		Requires the State Air Resources Board to conduct an assessment of the amount of decarbonized gaseous fuels that will be needed to decarbonize hard to electrify end uses and maintain reliability in the electricity sector and to post the assessment on its internet website. Requires the assessment to include an assessment of the need for decarbonized gaseous fuels for each hard to electrify end use.	05/06/2026: In ASSEMBLY Committee on APPROPRIATIONS: To Suspense File.
<b>CA AB 1853</b> (Pellerin (D))	Statewide Referendum: Fiscal Impact Statements		Clarifies that a condensed summary that appears on the ballot label includes the fiscal impact statement.	04/09/2026: In ASSEMBLY. Read third time. Passed ASSEMBLY. *****To SENATE.
<b>CA AB 1859</b> (Ortega (D))	Public Works		Requires an awarding body, regulating public works projects, or owner to give reasonable access, as defined, to representatives of a joint-labor management committee in order to monitor compliance with the prevailing wage and apprenticeship requirements. Authorizes the committee to bring an action against an awarding body, contractor, or subcontractor that willfully denies the committee's representative reasonable access.	04/22/2026: In ASSEMBLY Committee on APPROPRIATIONS: To Suspense File.
<b>CA AB 1862</b> (Boerner (D))	Health Care Districts: Transfers of Assets		Prohibits a health care district from entering into a transfer agreement that allows a private party to the agreement to prohibit, restrict, or otherwise place conditions upon the health care districts expenditure of taxpayer funds.	04/08/2026: In ASSEMBLY. Read second time and amended. Re-referred to Committee on LOCAL GOVERNMENT.

## IRWD 2024 LEGISLATIVE MATRIX

Updated: May 6, 2026

Bill No. Author	Title	IRWD Position	Summary/Effects	Status
CA AB 1866 (Rogers (D))	California Disaster Assistance Act: Minimum Damages		Provides that the California Disaster Assistance Act requires the Director of Emergency Services to provide financial assistance to local agencies for costs incurred as a result of a state of emergency. Provides that the act limits the State share for any eligible project to no more than a specified percent of total State eligible costs unless the local agency is located in a city or county that has adopted a local hazard mitigation plan. Specifies costs that may be included in the local agency cost share.	04/15/2026: In ASSEMBLY Committee on APPROPRIATIONS: To Suspend File.
CA AB 1873 (Bennett (D))	County of Ventura: Fire Suppression: Backup Energy		Requires a water supplier that uses a backup energy source that is not permanent and stationary to notify the Ventura County Office of Emergency Services as soon as practically possible, but no later than a specified number of hours after a loss of power, if that backup energy source does not provide power within a specified number of minutes of a loss of power.	05/04/2026: In ASSEMBLY. Read third time. Passed ASSEMBLY. *****To SENATE.
CA AB 1881 (Ramos (D))	California Indian Freedom Act of 2026	Seek Amendments	Requires a governmental agency to seek and document free, prior, and informed consent from affected tribes before undertaking any project action on State public lands that may pose a risk to sacred sites. Requires the affirmation of consent from the governing body of the affected tribe to be in writing.	05/06/2026: In ASSEMBLY Committee on APPROPRIATIONS: To Suspend File.
CA AB 1883 (Bryan (D))	Workplace Surveillance Tools		Prohibits an employer from using a workplace surveillance tool on workers for various purposes. Includes preventing compliance with laws or regulations, inferring information about workers engaging in a protected activity, making inferences about an individual's emotional state or based on their gait, or collecting neural data. Prohibits an employer from using facial recognition technology, unless it is used strictly to open a locked device or grant access to locked or secure areas.	04/29/2026: In ASSEMBLY Committee on APPROPRIATIONS: To Suspend File.
CA AB 1894 (Rubio (D))	Fish and Wildlife: Invasive Mussels: Imported Water		Prohibits a public agency from prohibiting imported water deliveries for groundwater replenishment due to invasive mussels	05/04/2026: In ASSEMBLY. Read third time. Passed ASSEMBLY. *****To SENATE.

## IRWD 2024 LEGISLATIVE MATRIX

Updated: *May 6, 2026*

Bill No. Author	Title	IRWD Position	Summary/Effects	Status
			unless there is substantial, documented evidence of a proven health and safety risk as a result of the invasive mussels.	
<b>CA AB 1895</b> (Hadwick (R))	Surplus Land Act: Exemptions: Land Unsuitable		Broadens the definition of exempt surplus land to include land that is unsuitable for housing development due to the presence of one or more specified characteristics, including land with slope instability that increases risk of mudslides, landslides, subsidence, liquefaction, and other seismic hazards.	03/02/2026: To ASSEMBLY Committees on LOCAL GOVERNMENT and HOUSING AND COMMUNITY DEVELOPMENT.
<b>CA AB 1898</b> (Schultz (D))	Workplace Artificial Intelligence Tools		Requires an employer to provide a written notice to a worker that a workplace artificial intelligence tool was used to assist the employer in making employment related decisions or to surveil workers in the workplace. Requires the notice to be given to a worker within a specified time and requires the notice to contain specified information, including the specific employment related decisions likely to be affected by the use of the workplace AI tool. Provides for civil actions for damages.	04/29/2026: In ASSEMBLY Committee on APPROPRIATIONS: To Suspend File.
<b>CA AB 1934</b> (Bennett (D))	State Fire Marshal: Home Hardening Certification		Requires the State Fire Marshals Wildfire Mitigation Advisory Committee to develop an implementation plan for a home hardening certification program that identifies home hardening measures, including defensible space, that can be voluntarily implemented during renovation or property improvement projects, or both, to substantially reduce the risk of loss during a fire. Requires the committee to provide a report to specified legislative committees.	04/13/2026: From ASSEMBLY Committee on NATURAL RESOURCES: Do pass to Committee on APPROPRIATIONS.
<b>CA AB 1947</b> (Ta (R))	Surplus Land		Relates to existing law which requires each state agency, each year, to make a review of all proprietary state lands over which it has jurisdiction to determine what land is in excess of its foreseeable needs and report thereon to the Department of General Services. The bill specifically requires the Department of Transportation to submit the report described above. The bill	05/06/2026: In ASSEMBLY Committee on APPROPRIATIONS: To Suspend File.

## IRWD 2024 LEGISLATIVE MATRIX

Updated: *May 6, 2026*

Bill No. Author	Title	IRWD Position	Summary/Effects	Status
			would require the report to include the market value of the properties reviewed by the agency.	
<b>CA AB 1960</b> (Bennett (D))	Wildfire Prevention Grants Program: Identified Cohesive		Authorizes the Department of Forestry and Fire Protection to disburse funds appropriated for the Wildfire Prevention Grants Program to identified cohesive fire communities that partner with fire safe councils to use for activities related to hazardous fuels reduction, wildfire prevention planning, and wildfire prevention education, among other activities. Requires the department to prioritize disadvantaged identified cohesive fire communities in its evaluation of applicants for the program.	05/06/2026: In ASSEMBLY Committee on APPROPRIATIONS: To Suspend File.
<b>CA AB 1964</b> (Bennett (D))	State Fire Marshal: County Recorder: Home Hardening		Requires a county recorder to maintain construction records related to home hardening and to share, upon request, construction records related to home hardening in a state or local responsibility area with the Office of the State Fire Marshal. Imposes additional duties on county recorders, the bill would impose a state-mandated local program. Requires the Office of the State Fire Marshal, on or before a specified date, to develop home hardening standards, as provided.	05/06/2026: In ASSEMBLY Committee on APPROPRIATIONS: To Suspend File.
<b>CA AB 1971</b> (Bennett (D))	Property Tax: Exclusion from Reassessment: Home		Requires the State Board of Equalization to clarify that a home hardening retrofitting improvement to an existing structure is considered nonassessable repair and maintenance, provided that the improvement does not add square footage, change the property's use, include structural reconfigurations, or include substantial rehabilitation.	04/22/2026: In SENATE. Read second time and amended. Re-referred to Committee on APPROPRIATIONS.
<b>CA AB 1972</b> (Patterson J (R))	Water Right Permits and Licenses: Annual Fee: Exemption		Provides that existing law requires each person or entity who holds a permit or license to appropriate water, leases water pursuant to specified provisions of law, or files a specified application, registration, or petition to pay a fee according to a fee schedule established by the State Water Resources Control Board. Requires the board to exempt a person who holds a water right	04/20/2026: In ASSEMBLY. Joint Rule 62(a) suspended.

## IRWD 2024 LEGISLATIVE MATRIX

Updated: May 6, 2026

Bill No. Author	Title	IRWD Position	Summary/Effects	Status
			permit or license from paying the annual fee pursuant to a specified regulation for a pond with a specified amount of water.	
<b>CA AB 1987</b> (Aguiar-Curry (D))	Department Managed Lands: Wildlife Areas: Hunting		Authorizes the Department of Fish and Wildlife to enter into contracts or other agreements for the management and operation of the department managed lands for the purposes of administrating hunting or other public use programs. Creates the Waterfowl Management Areas Operations and Maintenance Account in the Fish and Game Preservation Fund. Appropriates funds.	04/13/2026: In ASSEMBLY. Read third time. Passed ASSEMBLY. *****To SENATE.
<b>CA AB 1993</b> (DeMaio (R))	Voting by Mail: Identification Envelopes		Requires any perforation, hole, window, or other opening in an identification envelope to be located not less than one-half inch from any fillable field on the ballot, as measured when the ballot is fully inserted into the envelope according to instructions provided to the voter. Requires the Secretary of State to adopt regulations implementing the section.	03/25/2026: In ASSEMBLY Committee on ELECTIONS: Failed passage.
<b>CA AB 1997</b> (Lee (D))	Land Use: Housing Development Approvals: Timelines		Requires approval or disapproval of a housing development project within specified days from the date of certification by the lead agency of the EIR, if the EIR is prepared pursuant to specified provisions of California Environmental Quality Act (CEQA) if certain other conditions are met. Imposes additional duties on local agencies. Imposes a state-mandated local program.	04/27/2026: In ASSEMBLY. Read second time and amended. Re-referred to Committee on APPROPRIATIONS.
<b>CA AB 2013</b> (Bennett (D))	High and Very High Fire Risk Areas: Community Water	Oppose Unless Amended	Requires a community water system that services more than a specified number of customers that are located in a high or very high fire risk area to include an annex to its disaster preparedness plans that includes information regarding system preparedness and resiliency during a wildfire. Requires the community water system to review the annex at least once every specified number of years and to update the annex as necessary.	04/13/2026: From ASSEMBLY Committee on EMERGENCY MANAGEMENT: Do pass to Committee on ENVIRONMENTAL SAFETY AND TOXIC MATERIALS.

## IRWD 2024 LEGISLATIVE MATRIX

Updated: May 6, 2026

Bill No. Author	Title	IRWD Position	Summary/Effects	Status
<b>CA AB 2016</b> (Gonzalez Je (R))	State Water Resources Control Board: Drinking Water		Appropriates a specified amount from the General Fund to the State Water Resources Control Board for the purpose of removing hexavalent chromium from drinking water. Requires the board to make specified grants to specified entities to undertake construction or planning and design of facilities to remove hexavalent chromium from drinking water.	04/20/2026: Re-referred to ASSEMBLY Committee on ENVIRONMENTAL SAFETY AND TOXIC MATERIALS.
<b>CA AB 2026</b> (Aguiar-Curry (D))	Water Diversion: Groundwater Recharge: Permit		Revises and recasts the conditions required for the appropriative water right exemption for a diversion of floodflows for groundwater recharge. Applies certain requirements to a diversion commenced before the specified date and exempts those diversions from the requirements of the California Environmental Quality Act and requirements relating to lake or streambed alteration agreements, subject to conducting tribal consultations. Expands the definition of floodflow.	04/22/2026: In ASSEMBLY. Read second time and amended. Re-referred to Committee on APPROPRIATIONS.
<b>CA AB 2027</b> (Ward (D))	Worker Data: Prohibitions: Artificial Intelligence		Prohibits an employer from using a workers personal information to train an artificial intelligence system to replicate, automate, or replace a workers job, and prohibits an employer from selling, disclosing, or otherwise providing access to a workers personal information to a third party for the purpose of training an AI system to replicate, automate, or replace a job. Authorizes a worker who suffered a violation to bring a civil action for damages, injunctive relief, punitive damages, and attorneys fees.	05/06/2026: In ASSEMBLY Committee on APPROPRIATIONS: To Suspense File.
<b>CA AB 2032</b> (Ransom (D))	Fish and Wildlife: Golden Mussels		Requires, in response to an invasive species threat, including, but not limited to, the threat of golden mussels, the Department of Pesticide Regulation, the State Water Resources Control Board, and regional water quality control boards to work with State and local agencies in order to quickly and efficiently respond to the threat. Requires the department and State Board to identify any tools available to assist a State or local agency in rapidly responding to the invasive species threat.	04/16/2026: In ASSEMBLY. Read second time and amended. Re-referred to Committee on APPROPRIATIONS.

## IRWD 2024 LEGISLATIVE MATRIX

Updated: *May 6, 2026*

Bill No. Author	Title	IRWD Position	Summary/Effects	Status
<b>CA AB 2044</b> (Petrie-Norris (D))	Building Standards: Approval or Adoption: Cost		Prohibits the California Building Standards Commission from approving or adopting the proposed or adopted building standard, if the commission finds that the initial statement of reasons is submitted without a completed statement of estimated cost of compliance, as specified.	05/06/2026: From ASSEMBLY Committee on APPROPRIATIONS: Do pass. To Consent Calendar.
<b>CA AB 2045</b> (Connolly (D))	Habitat Restoration and Enhancement Act		Relates to the Habitat Restoration and Enhancement Act. Extends the operation of the act until the specified date. Requires the Department of Fish and Wildlife to submit a report on the implementation of the act to the Legislature no later than the specified date.	05/06/2026: In ASSEMBLY Committee on APPROPRIATIONS: To Suspend File.
<b>CA AB 2051</b> (Wicks (D))	Public Resources: Coastal Resilience Permitting		Requires the Secretary of the Natural Resources Agency to convene a Coastal Resilience Permitting Working Group for the purpose of developing a Coastal Resilience Permitting Roadmap for coastal resilience projects proposed in specified areas. Requires the Secretary of the Natural Resources Agency, in collaboration with, among others, the State Coastal Commission and the Department of Fish and Wildlife, to convene a Coastal Resilience Permit Advisory Group.	04/29/2026: In ASSEMBLY Committee on APPROPRIATIONS: To Suspend File.
<b>CA AB 2063</b> (Wallis (R))	Legislative Information System: Bill Position Letters		Adds all letters submitted through the Legislature's internet portal in connection with each bill, commencing with bills introduced during the 2027-28 Regular Session, to the information the Legislative Counsel is required to make publicly available in electronic form.	02/18/2026: INTRODUCED.
<b>CA AB 2075</b> (Bennett (D))	Forestry: Safety Requirements: Fire Equipment		Requires the State Board of Forestry and Fire Protection to adopt emergency regulations pursuant to the Administrative Procedure Act that, as applied to timber operations on timberland conducted by a timber operator, define the terms operating area and point accessible in the event of a fire and the necessary number and types of tools needed in the fire toolbox.	05/06/2026: In ASSEMBLY Committee on APPROPRIATIONS: To Suspend File.

## IRWD 2024 LEGISLATIVE MATRIX

Updated: *May 6, 2026*

Bill No. Author	Title	IRWD Position	Summary/Effects	Status
CA AB 2094 (Harabedian (D))	Social Housing Strategy and Implementation Program		Requires the Department of Housing and Community Development to establish a dedicated social housing coordinator to lead social housing strategy and implementation. Requires, in leading social housing strategy and implementation, the dedicated social housing coordinator to, among other things, inventory and prioritize surplus public land suitable for social housing development.	05/06/2026: In ASSEMBLY Committee on APPROPRIATIONS: To Suspend File.
CA AB 2098 (Kalra (D))	Workers Compensation: Medical Treatment		Relates to workers compensation. Provides that existing law makes it a misdemeanor for an employer to discharge, threaten to discharge, or discriminate against, or for an insurer to advise, direct, or threaten an insured to discharge, an employee because they have filed or made known their intention to file a claim for compensation. Requires the employee, if the timing of a medical treatment is foreseeable, to provide an employer notice if treatment occurs during work hours.	05/06/2026: In ASSEMBLY Committee on APPROPRIATIONS: To Suspend File.
CA AB 2100 (Connolly (D))	Organic Waste: Manure Management: Interagency		Requires the Department of Food and Agriculture to convene an interagency task force to evaluate the role of alternative manure management practices in achieving certain goals and to make specified findings and recommendations based on its evaluation. Requires the task force to, among other things, assess how alternative manure management practices can help the State meet groundwater sustainability plans, water quality plans, and nature based climate solutions.	04/29/2026: In ASSEMBLY Committee on APPROPRIATIONS: To Suspend File.
CA AB 2102 (DeMaio (R))	Wildfire: Vegetation Management: Fuel Reduction		Requires the Department of Forestry and Fire Protection or a local entity to conduct an assessment of all undeveloped public lands for which it is primarily responsible for preventing and suppressing fires to ensure that the public land is not a severe fire hazard. Requires this assessment to be posted on the department's and local entity's internet website and would require a local entity conducting the assessment to submit its assessment to the department.	03/09/2026: To ASSEMBLY Committees on NATURAL RESOURCES and EMERGENCY MANAGEMENT.

## IRWD 2024 LEGISLATIVE MATRIX

Updated: *May 6, 2026*

Bill No. Author	Title	IRWD Position	Summary/Effects	Status
<b>CA AB 2105</b> (Macedo (R))	Elections: Vote by Mail Ballots		Requires the Secretary of State to identify geographic areas where a vote by mail ballot deposited with the United States Postal Service on election day may not receive a postmark until the following day because of mail collection and processing practices in that region. Requires that the Secretary publish the list of identified geographic areas on its internet website and provide it to local elections officials.	03/02/2026: To ASSEMBLY Committee on ELECTIONS.
<b>CA AB 2106</b> (Patel (D))	Malpractice Actions: Architects, Engineers, or Surveyor		Expands the malpractice complaints covered by the provision to include those against landscape architects. Limits the practitioners that may be consulted to those who are licensed in this state.	04/30/2026: In ASSEMBLY. Read second time. To third reading.
<b>CA AB 2110</b> (Johnson N (R))	Local Financing: Workforce Housing: Tax Increment		Authorizes the establishment of tax increment financing districts for purposes of financing the construction, rehabilitation, repair, and upgrades to workforce housing for public safety, education, health care, or manufacturing personnel. Imposes limitations on the involvement of a city or county that created a redevelopment agency or a former redevelopment project in a district.	04/22/2026: From ASSEMBLY Committee on HOUSING AND COMMUNITY DEVELOPMENT: Do pass to Committee on APPROPRIATIONS.
<b>CA AB 2118</b> (Hoover (R))	Affordable Housing and High Road Jobs Act of 2022		Authorizes a development proponent to submit an application for a mixed-income housing development along a commercial corridor that satisfies specified site criteria, affordability criteria, and objective development standards, and deems a housing development that meets those requirements a use by right and subject to streamlined, ministerial review. Prohibits the objective standards from prohibiting or otherwise limiting mixed-use development in a housing development project. Makes nonsubstantive changes.	05/06/2026: From ASSEMBLY Committee on APPROPRIATIONS: Do pass.
<b>CA AB 2125</b> (Bennett (D))	Groundwater Basin Adjudication: Notice		Provides that existing law permits a court to authorize procedures it finds appropriate and necessary to provide notice to persons who may hold groundwater rights in basin. Clarifies that the court may authorize additional procedures necessary to provide notice	03/26/2026: In ASSEMBLY. Read second time. To third reading.

## IRWD 2024 LEGISLATIVE MATRIX

Updated: *May 6, 2026*

Bill No. Author	Title	IRWD Position	Summary/Effects	Status
			to persons who may hold groundwater rights in basin, including, but not limited to, requiring the plaintiff to utilize restricted delivery of all mailed notices.	
<b>CA AB 2132</b> (Macedo (R))	California Environmental Quality Act: Exemption		Exempts from the requirements of the California Environmental Quality Act a groundwater recharge project if the Secretary of the Natural Resources Agency determines the project would address subsidence.	04/06/2026: In ASSEMBLY. Assembly Rule 56 suspended.
<b>CA AB 2139</b> (Garcia Ro (D))	Surplus Lands: Exempt Surplus Land: City of Ontario		Expands the definition of exempt surplus land to include certain land owned by the City of Ontario that satisfies specified requirements. Requires that these requirements be contained in a covenant or restriction recorded against the surplus land at the time of disposition. Requires that the city meet specified requirements to declare exempt surplus land pursuant to these provisions, including depositing funds from the deposition into a local housing specific set aside account.	04/22/2026: From ASSEMBLY Committee on HOUSING AND COMMUNITY DEVELOPMENT: Do pass to Committee on APPROPRIATIONS.
<b>CA AB 2143</b> (Irwin (D))	Invasive Species: Noxious Weeds: Online Marketplaces		Provides that existing law prohibits a person from selling, distributing, or transporting into, or within, a weed free area any seed of a noxious weed that the Secretary of Food and Agriculture has declared the area to be practically free from. Prohibits an online marketplace from accepting payment for a noxious weed for delivery to an address located in the State. Authorizes the secretary to, in lieu of prosecution, levy an administrative penalty against an online marketplace that violates the prohibition.	04/22/2026: In ASSEMBLY Committee on APPROPRIATIONS: To Suspend File.
<b>CA AB 2166</b> (Carrillo J (D))	Multifamily Housing Development: Offsite Housing		Creates to the Bergeson-Peace Infrastructure and Economic Development Bank Act within the Governor's Office of Business and Economic Development the California Infrastructure and Economic Development Bank and requires it to administer the act, which, among other things, provides for the financing of certain economic development projects.	05/06/2026: In ASSEMBLY Committee on APPROPRIATIONS: To Suspend File.

## IRWD 2024 LEGISLATIVE MATRIX

Updated: May 6, 2026

Bill No. Author	Title	IRWD Position	Summary/Effects	Status
CA AB 2170 (Boerner (D))	California Environmental Quality Act: Overburdened		Relates to determinations by a lead agency, would require an environmental impact report, negative declaration, or mitigated negative declaration, as determined by the lead agency, for any project, except as provided, that includes the development, intensification, or substantial expansion of an industrial use if the project is located in or within 1/2 mile of an overburdened community.	05/06/2026: In ASSEMBLY Committee on APPROPRIATIONS: To Suspend File.
CA AB 2180 (Ward (D))	Local Government: Proposition 218 Omnibus	Support	Relates to assessments and property related fees. Relates to the Proposition 218 Omnibus Implementation Act. Provides that the proportional cost of service in each tier of water service may be substantiated by using any reasonable basis for allocating costs attributed to the tier. Provides a local government discretion to determine the costs allocated to each tier as long as the rate for each tier does not exceed the proportional cost of service reasonably allocated to parcels subject to that tier.	04/09/2026: In ASSEMBLY. Read third time. Passed ASSEMBLY. *****To SENATE.
CA AB 2184 (Wilson (D))	Cap and Invest Program: Nature Based Climate Solutions		Appropriates funds from the Greenhouse Gas Reduction Fund to achieve nature based climate solutions on natural, working, and urban lands, including a specified amount to be allocated to the Natural Resources Agency to fund nature based climate solutions, and a specified amount to be allocated for nature based climate solutions at the discretion of the Legislature. Appropriates funds to the Department of Food and Agriculture to fund sustainable agricultural practices and nature based climate solutions.	04/22/2026: In ASSEMBLY Committee on APPROPRIATIONS: To Suspend File.
CA AB 2185 (Quirk-Silva (D))	Housing: Multifamily Affordable Housing Programs		Requires the State Housing and Homelessness Agency, the State Housing Finance Agency, the State Debt Limit Allocation Committee, and the State Tax Credit Allocation Committee, no later than the specified date, when administering a multifamily affordable housing program, to, among other things, review, analyze, and make any changes necessary to their guidelines and regulations to facilitate the production and use of factory built housing.	04/22/2026: From ASSEMBLY Committee on HOUSING AND COMMUNITY DEVELOPMENT: Do pass to Committee on APPROPRIATIONS.

## IRWD 2024 LEGISLATIVE MATRIX

Updated: May 6, 2026

Bill No. Author	Title	IRWD Position	Summary/Effects	Status
<b>CA AB 2190</b> (Wallis (R))	Internet Website Accessibility		Provides that existing law imposes liability upon a person who denies, aids, or incites a denial of, or makes any discrimination or distinction contrary to, rights afforded by law for actual damages suffered, exemplary damages, a civil penalty, and attorney's fees, as specified, to any person who was denied the specified rights. Prohibits a resource service provider from, in exchange for money or any other form.	04/23/2026: In ASSEMBLY. Read second time and amended. Re-referred to Committee on APPROPRIATIONS.
<b>CA AB 2215</b> (Calderon (D))	Water Rights: Permits: State Water Project	Support	Provides that existing law requires that construction work for a project that will put appropriated water to beneficial use be commenced, prosecuted with due diligence, and completed within the time period specified in the water right permit. Specifies the time periods for the application of water to beneficial use and for the completion of construction work for specific water right permits held by the Department of Water Resources for the operation of the State Water Project.	04/30/2026: In ASSEMBLY. Read second time. To third reading.
<b>CA AB 2216</b> (Aguiar-Curry (D))	Sacramento San Joaquin Delta Conservancy		Relates to the Sacramento San Joaquin Delta Conservancy. Expands the area covered by the conservancy to include the Valley. Renames the conservancy the Valley and Delta Conservancy, renames the Sacramento San Joaquin Delta Conservancy Fund the Valley and Delta Conservancy Fund. Adds liaison advisers who are designees of the Sierra Nevada Conservancy and the San Joaquin River Conservancy. Authorizes the conservancy to engage in partnerships with tribal organizations. Establishes the Valley Program.	04/22/2026: In ASSEMBLY Committee on APPROPRIATIONS: To Suspense File.
<b>CA AB 2218</b> (Kalra (D))	Water Policy: State Native American Tribes	Seek Amendments	Declares that it is the established policy of the State to recognize and address inequities inflicted upon all State Native American tribes through financial assistance, protection of tribal water uses, consultation on water projects, plans, and policies, and incorporation of Indigenous knowledge to restore and protect ecosystems. Requires specified agencies, including the Water	05/06/2026: In ASSEMBLY Committee on APPROPRIATIONS: To Suspense File.

## IRWD 2024 LEGISLATIVE MATRIX

Updated: *May 6, 2026*

Bill No. Author	Title	IRWD Position	Summary/Effects	Status
			Resources Control Board, regional water quality control boards, and the Natural Resources Agency, to incorporate this policy.	
CA AB 2252 (Lee (D))	Building Standards: Residential Buildings		Requires the Department of Housing and Community Development to research, develop, and propose building standards for single exit, single stairway multiunit residential buildings of up to a specified number of stories in height for inclusion in the next triennial edition of the State Building Standards Code. Requires, in developing these standards, the department to consult with the State Fire Marshal.	04/22/2026: In ASSEMBLY Committee on HOUSING AND COMMUNITY DEVELOPMENT: Heard, remains in Committee.
CA AB 2254 (Addis (D))	Coastal Resources: Local Coastal Program: Monarch		Requires the Department of Fish and Wildlife, in coordination with the State Coastal Commission, to identify monarch butterfly overwintering habitat sites in the coastal zone and current local government monarch butterfly overwintering habitat management plans or policies. Requires the department, in coordination with the commission, to provide guidance on model policies to be used by a local government for the protection of monarch butterfly overwintering habitat, including habitat restoration.	05/06/2026: In ASSEMBLY Committee on APPROPRIATIONS: To Suspend File.
CA AB 2255 (Pellerin (D))	Political Reform Act of 1974: Candidate Controlled		Requires a candidate controlled committee established for an elective office for the controlling candidate to report additional information on its campaign statement if the candidate will not appear on the ballot at the next election and the committee makes expenditures to a single person exceeding a specified amount in the aggregate during the reporting period.	05/06/2026: From ASSEMBLY Committee on APPROPRIATIONS: Do pass. To Consent Calendar.
CA AB 2260 (Connolly (D))	Water: Restoration Management: Small Restoration Use		Relates to the Water Rights Permitting Reform Act. Provides that existing law requires the renewal of registration of a small domestic, small irrigation, or livestock stockpond use pursuant to a specified process prior to the expiration of each specified period following completed registration. Applies such provisions to a small restoration use.	04/08/2026: In ASSEMBLY Committee on APPROPRIATIONS: To Suspend File.

## IRWD 2024 LEGISLATIVE MATRIX

Updated: May 6, 2026

Bill No. Author	Title	IRWD Position	Summary/Effects	Status
CA AB 2265 (Garcia Ro (D))	Emergency Services: Law Enforcement and Intelligence		States that it is the intent of the Legislature to enact legislation that would require the State Threat Assessment Center to develop an intelligence sharing plan that respects individual's privacy and civil rights.	02/19/2026: INTRODUCED.
CA AB 2296 (Papan (D))	Planning and Zoning: Housing Element: Regional Housing		Provides that the Planning and Zoning Law requires each county and city to adopt a general plan which includes a housing element. Requires, if the Department of Housing and Community Development finds that a draft element or amendment does not substantially comply with housing element law, the department to provide a written communication to the planning agency containing certain information, including the specific analysis or text that the department expects the planning agency to include in the draft.	05/06/2026: In ASSEMBLY Committee on APPROPRIATIONS: To Suspend File.
CA AB 2322 (Papan (D))	Water Discharge: Commercial, Industrial, or Institution		Provides that under existing law, the State Water Resources Control Board and the 9 regional water quality control boards issue permits for the discharge of stormwater from municipal separate storm sewer systems. Defines, for purposes of issuing permits for the discharge of stormwater from MS4s, commercial, industrial, or institutional site or CII site as a privately owned parcel or contiguous parcels of land that are commercial, industrial, or institutional based on county tax assessor land use codes.	04/30/2026: In ASSEMBLY. Read second time. To third reading.
CA AB 2334 (Bennett (D))	Solid Waste: Methane Reduction: Working Group		Provides that existing law establishes the Department of Resources Recycling and Recovery, which is administered under the control the Director of Resources Recycling and Recovery. Requires the Director of Resources Recycling and Recovery to establish a working group to study the need for and value of alternative methods of methane reduction. Requires the working group to submit its findings and recommendations to the director on or before the specified date.	04/29/2026: In ASSEMBLY Committee on APPROPRIATIONS: To Suspend File.

## IRWD 2024 LEGISLATIVE MATRIX

Updated: May 6, 2026

Bill No. Author	Title	IRWD Position	Summary/Effects	Status
CA AB 2341 (Fong M (D))	Local Government: Emergency Response Services		Requires a local agency to provide information related to an emergency within a local agency's jurisdiction in English and translated in each language spoken by a specified percent or more of the population that speaks English less than very well. Requires a local agency to calculate the total population of those within its jurisdiction that speak English less than very well.	05/05/2026: In ASSEMBLY. Read third time and amended. To third reading.
CA AB 2349 (Solache (D))	State Air Resources Board: Regional Air Quality		Requires the State Air Resources Board to expand its incident air monitoring program, subject to an appropriation by the Legislature for those purposes, to provide support for a regional network of air quality incident response centers, including at least one air quality incident response and evaluation center located at the South Coast Air Quality Management District, in order to facilitate emergency air monitoring response at the local and regional level.	04/22/2026: In ASSEMBLY Committee on APPROPRIATIONS: To Suspense File.
CA AB 2366 (Avila Farias (D))	Administrative Procedure Act: Proposed Regulations		Includes requirement under the Administrative Procedure Act requirements for assessing the potential for adverse economic impact the consideration of the proposal's cost-of-living impacts on residents of the state, as defined.	05/06/2026: In ASSEMBLY Committee on APPROPRIATIONS: To Suspense File.
CA AB 2373 (Dixon (R))	The State Coastal Act: Local Coastal Program		Authorizes local governments lying, in whole or in part, within the coastal zone to include a neighborhood-scale adaptation approach, as defined, when including land use policies and implementation measures in their local coastal program or sea level rise plan.	05/06/2026: In ASSEMBLY Committee on APPROPRIATIONS: To Suspense File.
CA AB 2381 (Johnson N (R))	Local Agency Public Construction Act: Water Districts		Relates to existing law under which a municipal water district and a sanitation district, when letting a contract for a specified amount or more, is required to let the contract to the lowest responsible bidder. Increases that threshold dollar amount.	03/09/2026: To ASSEMBLY Committee on LOCAL GOVERNMENT.

## IRWD 2024 LEGISLATIVE MATRIX

Updated: *May 6, 2026*

Bill No. Author	Title	IRWD Position	Summary/Effects	Status
CA AB 2383 (Zbur (D))	Electricity: Large Energy Use Facilities		Requires the commission on or before specified date in a new or existing proceeding, to provide for a classification of retail electricity consumers that are large energy use facilities that is separate and distinct from classifications of service for other commercial or industrial retail electricity consumers and has its schedule, as specified. Requires a load-serving entity that is providing electricity service to a large energy use facility to enter into a contract with the large energy use facility.	04/13/2026: In ASSEMBLY. Read second time and amended. Re-referred to Committee on APPROPRIATIONS.
CA AB 2385 (Petrie-Norris (D))	Local Reconstruction Agencies		Requires a city or county that prepares a disaster recovery plan to amend its general plan to ensure consistency between both plans. Authorizes a city, county, or city and county that takes certain actions pursuant to the bill to adopt an ordinance establishing a local reconstruction agency to coordinate disaster recovery efforts in the areas impacted by a disaster. Requires the ordinance to state that incremental property tax revenue from the city or county and all affected taxing entities, as defined.	04/27/2026: In ASSEMBLY. Read second time and amended. Re-referred to Committee on APPROPRIATIONS.
CA AB 2410 (Ellis (R))	Wildfire Safety: Fuels Reduction Projects		Requires each local government lying in whole or in part within the coastal zone to prepare a local coastal program for that portion of the coastal zone within its jurisdiction and prescribes procedures for the preparation, approval, and certification of local coastal programs. Prohibits, after certification of a local coastal program and all implementing actions within the affected area, the commission from exercising its coastal development permit review authority over any new development within the area.	05/06/2026: In ASSEMBLY Committee on APPROPRIATIONS: To Suspense File.
CA AB 2412 (Ta (R))	State Agencies or Departments: Public Communications		Provides that existing law requires a State agency or department that utilizes generative artificial intelligence to directly communicate with a person regarding government services and benefits to ensure that those communications include a disclaimer that indicates to the person that the communication was generated by GenAI. Requires that disclaimer when a State agency or department communicates with the public.	05/04/2026: In ASSEMBLY. Read third time. Passed ASSEMBLY. *****To SENATE.

## IRWD 2024 LEGISLATIVE MATRIX

Updated: May 6, 2026

Bill No. Author	Title	IRWD Position	Summary/Effects	Status
CA AB 2413 (Ransom (D))	Large Format Public Advertisements: Public Expense		Provides that the Political Reform Act of 1974 provides for the comprehensive regulation of campaign financing and activities. Defines large format public advertisement as a billboard, wrap on a bus or other public transportation vehicle, advertisement affixed to a bus stop, and other public advertisements that are a specified size or larger. Prohibits a large format public advertisement from being published or displayed at public expense under certain conditions.	05/06/2026: From ASSEMBLY Committee on APPROPRIATIONS: Do pass.
CA AB 2418 (Gonzalez Ma (D))	Local Building Permits: Nonresidential Private Permits		Relates to require the local agency to, upon an applicant request, contract with or employ a private plan-checking entity if the estimated timeframe would result in an excessive delay or if there is excessive delay by the local agency. Concerns the local agency determines no private entities or persons are available or qualified to perform plan-checking services, the bill would authorize the applicant to retain, at their sole expense, a private professional provider, as defined and specified.	04/21/2026: From ASSEMBLY Committee on JUDICIARY: Do pass to Committee on APPROPRIATIONS.
CA AB 2421 (Valencia (D))	Political Reform Act of 1974: Committee Termination		Provides that if the Secretary of State determines that certain conditions are present, the Secretary of State must provide notice to committees that receive contributions totaling a specified amount or more per year that the committee may be terminated a certain number of days after the notice is sent. Specifies those conditions, including if the committee failed to submit a campaign report for a certain period and had a specified ending cash balance or less on its last campaign statement.	05/06/2026: From ASSEMBLY Committee on APPROPRIATIONS: Do pass. To Consent Calendar.
CA AB 2423 (Patterson J (R))	Agriculture: Cotton Pests Abatement Districts		Provides that existing law provides procedures for the formation of pest abatement districts for the purpose of pest control or abatement. Provides that the Cotton Pests Abatement District Act authorizes the organization and establishment of cotton pests abatement districts by the boards of supervisors of the Counties of Imperial, Los Angeles, Orange, Riverside, San Bernardino, San	04/23/2026: In ASSEMBLY. Read third time. Passed ASSEMBLY. *****To SENATE.

**IRWD 2024 LEGISLATIVE MATRIX**

Updated: *May 6, 2026*

Bill No. Author	Title	IRWD Position	Summary/Effects	Status
			Diego, and Ventura. Removes the authority to establish these districts in the Counties of Orange, San Diego, and Ventura.	
CA AB 2432 (Ellis (R))	State Air Resources Board: Regulations: Analysis		Provides that existing law imposes various limitations on emissions of air contaminants for the control of air pollution. Requires the State Air Resources Board, when it revises, adopts, or establishes any policy, standard, rule, or regulation that would have a direct financial impact on drivers in the State, to consider the financial burden on drivers, and to prepare a thorough analysis and evaluation of the financial impact of the proposed action on drivers to ensure full transparency.	03/23/2026: In ASSEMBLY. Read second time and amended. Re-referred to Committee on NATURAL RESOURCES.
CA AB 2433 (Alvarez (D))	Housing Development: Density Bonus		Provides that existing law defines density bonus for the purposes of the Density Bonus Law to mean a density increase over the otherwise base density. Provides that existing law requires the density bonus to be permitted in geographic areas of a housing development other than the areas where units for lower income households are located. Requires a density bonus, incentive, or concession, or waiver or reduction, on sites that are the subject of the same housing development.	04/22/2026: In ASSEMBLY. Read second time and amended. Re-referred to Committee on APPROPRIATIONS.
CA AB 2447 (Bauer-Kahan (D))	Water: Nitrogen Pollution Reduction Act		Provides that under the Porter Cologne Water Quality Control Act, the State Water Resources Control Board and the State regional water quality control boards are the principal State agencies with authority over matters relating to water quality. Requires the State Water Resources Control Board to require the regional boards to update the Irrigated Lands Regulatory Program in order to reduce nitrogen waste discharges from commercial irrigated agricultural areas.	05/06/2026: In ASSEMBLY Committee on APPROPRIATIONS: To Suspense File.
CA AB 2469 (Papan (D))	Data Centers: Water Use Disclosures		Requires the Department of Water Resources to recommend no later than the specified date, and the State Water Resources Control Board to adopt, no later than the specified date, a commercial, industrial, institutional, and large landscape water	05/06/2026: In ASSEMBLY Committee on APPROPRIATIONS: To Suspense File.

## IRWD 2024 LEGISLATIVE MATRIX

Updated: *May 6, 2026*

Bill No. Author	Title	IRWD Position	Summary/Effects	Status
			use classification for users that qualify as large consumptive use facilities, including data centers. Requires that this classification be separate and distinct from classifications applicable to other CII water use.	
<b>CA AB 2473</b> (Assembly Emergency Management Committee)	Wildfire Forecast and Threat Intelligence Integration		Requires the Wildfire Forecast and Threat Intelligence Integration Center to create a written report that contains specified information analyzing forecasted extreme, life threatening fire weather conditions and disseminate it to the California State Warning Center. Requires the California State Warning Center to proactively disseminate the report and related information to operational area duty officers and public safety answering points within the geography of an impacted area.	04/29/2026: In ASSEMBLY Committee on APPROPRIATIONS: To Suspense File.
<b>CA AB 2475</b> (Assembly Emergency Management Committee)	Standardized Emergency Management System		Requires the Office of Emergency Services to complete a specified number of after action reports, the first within the first specified number of days of a declaration of a state of emergency and the second no later than a specified number of days after a declared state of emergency ends. Requires a city, county, or city and county to complete an after action report within a certain period and to make the report available to the Office of Emergency Services.	04/29/2026: In ASSEMBLY Committee on APPROPRIATIONS: To Suspense File.
<b>CA AB 2480</b> (Avila Farias (D))	Housing Development: Density Bonus: Student Housing		Revises, for the purposes of a student housing development being eligible for a density bonus, the rent requirements for the applicable units of the development for lower income students. Requires a city or county to provide an additional density bonus for a student housing development that meets the requirements for being eligible for the density bonus and meets other specified criteria, including that the applicant agrees to include additional rental units affordable to moderate income students.	05/06/2026: From ASSEMBLY Committee on APPROPRIATIONS: Do pass.

## IRWD 2024 LEGISLATIVE MATRIX

Updated: May 6, 2026

Bill No. Author	Title	IRWD Position	Summary/Effects	Status
CA AB 2494 (Rogers (D))	State Forests: Forest Management		Provides that existing law authorizes the Department of Forestry and Fire Protection to engage in management of State forests. Specifies that certain timber harvesting is permissible. Declares it to be the policy of the State to accept or acquire lands, the reforestation or restoration of which is not assured under private ownership, to restore those lands with locally appropriate species and manage those lands for public benefit.	04/15/2026: In ASSEMBLY Committee on APPROPRIATIONS: To Suspend File.
CA AB 2498 (Chen (R))	Exempt Surplus Land: Surplus Land		Relates to the disposal of surplus land by a local agency. Provides that under existing law, exempt surplus land includes surplus land that is subject to a valid legal restriction. Provides that existing law specifies that valid legal restrictions for these purposes include existing leases, or other contractual obligations or restrictions, if the terms were agreed to prior to the specified date. Specifies that the requirements of an option agreement are among the contractual obligations or restrictions.	03/19/2026: In ASSEMBLY. Read second time and amended. Re-referred to Committee on LOCAL GOVERNMENT.
CA AB 2501 (Lackey (R))	Local Government		Makes nonsubstantive changes to the withdrawal provision in law authorizing the legislative bodies of local agencies to enter into associations.	02/20/2026: INTRODUCED.
CA AB 2513 (Petrie-Norris (D))	Wildfire: Regional Forest and Fire Capacity Program		Provides that existing law establishes a Regional Forest and Fire Capacity Program to support regional leadership to build local and regional capacity and develop, prioritize and implement strategies and projects that create fire adapted communities and landscapes. Provides that existing law authorizes the Department of Conservation to authorize advance grant payments. Authorizes the Director of the department to directly award regional landscape grants to regional entities to implement priority strategies.	04/29/2026: In ASSEMBLY Committee on APPROPRIATIONS: To Suspend File.
CA AB 2517 (Calderon (D))	Fire Safety: Fire Hazard Severity Zones		Requires the State Fire Marshal to, before finalizing the designation of local responsibility areas as moderate, high, and very high fire hazard severity zones, post specified information	04/23/2026: From ASSEMBLY Committee on EMERGENCY

**IRWD 2024 LEGISLATIVE MATRIX**

Updated: May 6, 2026

Bill No. Author	Title	IRWD Position	Summary/Effects	Status
			on its public internet website, provide at least one workshop on the draft maps for stakeholder participation, host a public comment period, respond to all written comments by local agencies regarding land use and zoning matters, and coordinate with other State agencies to help educate their constituencies.	MANAGEMENT: Do pass to Committee on APPROPRIATIONS.
<b>CA AB 2543</b> (Ransom (D))	Emergency Preparedness: Direct Current Fast Charging		Establishes various duties and responsibilities of the State Energy Resources Conservation and Development Commission relating to energy usage in the state, including to carry out research and development into alternative sources of energy, improvements in energy generation, transmission, and siting, fuel substitution, and other topics related to energy supply, demand, public safety, ecology, and conservation that are of particular statewide importance.	05/06/2026: In ASSEMBLY Committee on APPROPRIATIONS: To Suspend File.
<b>CA AB 2568</b> (Johnson N (R))	Water District Directors: Compensation		Authorizes a water district that has at least 90,000 residents within its jurisdiction to adopt an ordinance that compensates members of the governing board for up to a total of 15 days in any calendar month, but would require the members of the governing board of a water district that compensates its members for more than 10 days in a calendar month to annually adopt a written policy describing, based on a finding supported by substantial evidence.	05/04/2026: In ASSEMBLY. Read second time. To third reading.
<b>CA AB 2569</b> (Hart (D))	California Environmental Quality Act: Natural Hazards		Expand the definitions of "environment" and "significant effect on the environment" under CEQA to include impacts on people. The bill would additionally require the lead agency to include in the EIR a detailed statement on any significant effects that may result from locating the proposed project near, or attracting people to, existing or reasonably foreseeable natural hazards or adverse environmental conditions.	04/29/2026: In ASSEMBLY Committee on APPROPRIATIONS: To Suspend File.

## IRWD 2024 LEGISLATIVE MATRIX

Updated: May 6, 2026

Bill No. Author	Title	IRWD Position	Summary/Effects	Status
CA AB 2573 (Sharp-Collins (D))	Voter Registration Information: Elected Officials		Provides that under existing law, the residence address, phone number, and email address of a registered voter is confidential, except that under certain circumstances a county elections official must disclose that information to certain candidates and to any committee for or against any initiative or referendum. Permits the information of an elected officials immediate family member to be made confidential. Requires the official or candidate to make a written request to the county elections official.	05/06/2026: In ASSEMBLY Committee on APPROPRIATIONS: To Suspend File.
CA AB 2576 (Harabedian (D))	Transit Oriented Development		Provides that existing law specifies that a local government that denies a housing development project meeting certain requirements located in a high resource area is liable for certain penalties. Excludes from such provisions a contributing site within a historic district included on the State Historic Resources Inventory designated before the specified date and a parcel individually listed as a historical resource included on the State Historic Resources Inventory before the specified date.	05/04/2026: In ASSEMBLY. Read third time. Passed ASSEMBLY. *****To SENATE.
CA AB 2577 (Connolly (D))	Safe Drinking Water and Toxic Enforcement Act of 1986		Provides that the Safe Drinking Water and Toxic Enforcement Act authorizes a person to bring an action to enforce the requirements of the act if specified requirements are met. Requires the court to find that a settlement provides a public benefit and is in the public interest. Requires, under a specified circumstance, the court to find that the settlement would require the defendant to reduce the exposure to the listed chemical from the level that existed before the settlement.	05/06/2026: From ASSEMBLY Committee on APPROPRIATIONS: Do pass.
CA AB 2586 (Rodriguez Ce (D))	Fire Prevention: Air Quality and Smoke Monitoring		Makes a nonsubstantive change to the provision requiring the Department of Forestry and Fire Protection and the State Air Resources Board to develop and fund a program, upon appropriation by the Legislature, to enhance air quality and smoke monitoring, and to provide a public awareness campaign regarding prescribed burns.	02/20/2026: INTRODUCED.

## IRWD 2024 LEGISLATIVE MATRIX

Updated: *May 6, 2026*

Bill No. Author	Title	IRWD Position	Summary/Effects	Status
<b>CA AB 2590</b> (Gonzalez Je (R))	Resource Conservation: Sentinel Landscapes		Authorizes the Department of Conservation and the Strategic Growth Council, in evaluating applications for grants pursuant to the Sustainable Agricultural Lands Conservation Program, the State Coastal Conservancy, and Sierra Nevada Conservancy, in evaluating applications for grants, to give priority consideration to projects within a federally designated sentinel landscape. Appropriates funds.	05/06/2026: In ASSEMBLY Committee on APPROPRIATIONS: To Suspend File.
<b>CA AB 2592</b> (Pacheco (D))	Lobbyist Training		Requires the Fair Political Practices Commission to develop, maintain, and offer an orientation course for registered lobbyists on the relevant ethical issues and laws relating to lobbying, and on each house of the legislatures policies against harassment, including sexual harassment, in connection with lobbying activities. Requires the course be developed with the legislative ethics committees and gives the committees final approval over the content of the course that relates to harassment policies.	05/06/2026: In ASSEMBLY Committee on APPROPRIATIONS: To Suspend File.
<b>CA AB 2603</b> (Lowenthal (D))	Hiring of Real Property: Dwellings: Untenantability		Makes a nonsubstantive change to provisions requiring that any building with a dwelling unit maintain certain characteristics in order to be tenable, to include describing floors, stairways, and railings.	02/20/2026: INTRODUCED.
<b>CA AB 2604</b> (Berman (D))	Elections: Ballot Curing		Requires the Secretary of State to either implement a system that allows voters to access text-message-based ballot curing, as defined, or make available to county registrars the resources necessary to implement such a system, as specified.	05/06/2026: In ASSEMBLY Committee on APPROPRIATIONS: To Suspend File.
<b>CA AB 2619</b> (Papan (D))	Water Resources: Data Centers		Requires a person who owns or operates a data center, prior to applying to a city or a county for an initial business license, equivalent instrument, or permit, to provide its water supplier, under penalty of perjury, an estimate of the expected water use, the anticipated source of water, and the data centers projected water use volume for the maximum day, maximum month, and	05/06/2026: In ASSEMBLY Committee on APPROPRIATIONS: To Suspend File.

## IRWD 2024 LEGISLATIVE MATRIX

Updated: *May 6, 2026*

Bill No. Author	Title	IRWD Position	Summary/Effects	Status
			average year. Requires a person who owns or operates a data center to report the data centers annual water use.	
<b>CA AB 2623</b> (Petrie-Norris (D))	Public Utilities: Rate Changes: Notifications		Provides that existing law prohibits a public utility from making a change in a rate or classification unless the public utility provides 30 days notice to the Public Utilities Commission and the public. Extends the notice requirement to a specified number of days.	03/16/2026: In ASSEMBLY. Read second time and amended. Re-referred to Committee on UTILITIES AND ENERGY.
<b>CA AB 2630</b> (Bennett (D))	Water Diversion and Use: Adoption of Regulations		Provides that existing law authorizes the State Water Resources Control Board to adopt regulations requiring measurement and reporting of water diversion and use by persons, including those authorized to appropriate water under a registration for small domestic, small irrigation, or livestock stockpond use. Requires, until the specified date, that further regulations adopted pursuant to these provisions be adopted as emergency regulations and exempts them from the California Environmental Quality Act.	03/26/2026: In ASSEMBLY. Read second time and amended. Re-referred to Committee on NATURAL RESOURCES.
<b>CA AB 2653</b> (Lee (D))	State Contracts: Report: Modern Foundation Models		Requires the Department of Industrial Relations, in consultation with the Department of Technology, to convene a Foundation Model Labor and Procurement Working Group consisting of 9 members, assess labor practices underlying the development of modern foundation models and associated artificial intelligence systems and develop recommendations regarding whether and how the state should incorporate labor standards into procurement decisions for foundation models and associated artificial intelligence systems.	05/06/2026: In ASSEMBLY Committee on APPROPRIATIONS: To Suspense File.
<b>CA AB 2655</b> (Valencia (D))	Campaign Funds: Security Expenses: Security Personnel		Limits the use of campaign funds to pay for security personnel to only those instances where the security personnel hold the appropriate license issued by the Bureau of Security and Investigative Services.	04/30/2026: In ASSEMBLY. Read second time. To Consent Calendar.

## IRWD 2024 LEGISLATIVE MATRIX

Updated: May 6, 2026

Bill No. Author	Title	IRWD Position	Summary/Effects	Status
CA AB 2656 (Petrie-Norris (D))	Public Employees: Notice: Artificial Intelligence		Relates to the deployment of generative artificial intelligence (GenAI) tools by the State. Requires certain State and local public employers to provide written notice to a recognized employee organization at least a specified number of days before taking an action to develop, purchase, implement, or utilize GenAI to perform a service that is within the scope of work of the job classification represented by the recognized employee organization.	05/06/2026: In ASSEMBLY Committee on APPROPRIATIONS: To Suspend File.
CA AB 2691 (Addis (D))	Elections: Elective Office: Felony Conviction		Prohibits the consideration of a person as a candidate for, and provides that the person is not eligible to be elected to, any State or local elective office if they have been convicted of a felony involving sexual assault or human trafficking.	04/27/2026: In ASSEMBLY. Read third time. Passed ASSEMBLY. *****To SENATE.
CA AB 2728 (Soria (D))	Open and Transparent Water Data Act		Relates to the Open and Transparent Water Data Act. Requires the Department of Water Resources, in consultation with the State Water Quality Monitoring Council, the State Water Resources Control Board, and the Department of Fish and Wildlife, in accordance with a specified schedule, to create, operate, and maintain a statewide integrated water data platform that, among other things, integrates existing water and ecological data information from multiple databases.	04/29/2026: In ASSEMBLY Committee on APPROPRIATIONS: To Suspend File.
CA AB 2736 (Johnson N (R))	California Environmental Quality Act		Makes nonsubstantive changes to findings and declarations regarding the maintenance of a quality environment for the people of this state and to the statement of intent of the California Environmental Quality Act.	02/20/2026: INTRODUCED.
CA AB 2739 (Soria (D))	Water: Affordability and System Stabilization	Sponsor/ Support	Establishes the Water Affordability and System Stabilization Fund for holding the principal and income of the Water Affordability and System Stabilization Trust. Requires the trustee of the trust to, among other things, hold, manage, and invest the principal of the trust with the obligation of providing a growing perpetual source of annual funding to the Water Rate Assistance	04/29/2026: In ASSEMBLY Committee on APPROPRIATIONS: To Suspend File.

## IRWD 2024 LEGISLATIVE MATRIX

Updated: May 6, 2026

Bill No. Author	Title	IRWD Position	Summary/Effects	Status
			Fund and the Community Water Affordability Assistance Fund. Appropriates funds.	
CA AB 2752 (Avila Farias (D))	Bay Area Air Quality Management District		Provides that existing law establishes the South Coast Air Quality Management District as the local agency with the responsibility for comprehensive air pollution control within the South Coast Air Basin. Requires the Bay Area Air Quality Management District and the South Coast Air Quality Management District, on or before the specified date, to analyze specified policies to determine, among other things, impacts on State and local tax revenue, refinery employment, and statewide gasoline supply.	04/20/2026: In ASSEMBLY Committee on NATURAL RESOURCES: Failed passage.
CA AB 2755 (Elhawary (D))	Unlawful Detainer Defined		Makes a technical, nonsubstantive change to provisions relative to unlawful detainers definitions.	02/20/2026: INTRODUCED.
CA AB 2777 (Assembly Environmental Safety and Toxic Materials Committee)	State Water Pollution Control Revolving Fund Program	Support	Relates to the State Water Pollution Control Revolving Fund Program, where certain funds are continuously appropriated from the State Water Pollution Control Revolving Fund to the State Water Resources Control Board for loans and other financial assistance for purposes related to the federal Clean Water Act. Relates to the State Water Pollution Control Revolving Fund Administration Fund. Authorizes the board to assess fees in place of an annual charge for financial assistance.	05/06/2026: In ASSEMBLY Committee on APPROPRIATIONS: To Suspense File.
CA ACA 1 (Valencia (D))	Public Finance		Relates to public finance. Changes the 1.5% required transfer to an undetermined percentage of the estimated amount of General Fund revenues for that fiscal year. Changes the 10% limit on the balance in the Budget Stabilization Account to 20% of the amount of the General Fund proceeds of taxes for the fiscal year estimate, as specified. Specifies that funds transferred under these provisions to the Budget Stabilization Account do not constitute appropriations subject to a specified appropriations limit.	12/02/2024: INTRODUCED.

## IRWD 2024 LEGISLATIVE MATRIX

Updated: *May 6, 2026*

Bill No. Author	Title	IRWD Position	Summary/Effects	Status
CA ACA 7 (Jackson (D))	Government Preferences		Provides that the State Constitution, pursuant to provisions enacted by the Proposition 209, prohibits the State from discriminating against, or granting preferential treatment to, any individual or group on the basis of race, sex, color, ethnicity, or national origin in the operation of public employment, public education, or public contracting. Limits the prohibition to the operation of public employment, higher education admissions and enrollment, and public contracting.	02/19/2026: To SENATE Committee on RULES.
CA ACA 16 (Ellis (R))	Budget Bill: Balanced Budget: Members of Legislature		Authorizes the Controller, no later than 30 days after the date of the budget bill's passage, to determine that the budget bill violates the balanced budget provision. If the Controller makes that determination, the Members of the Legislature and the Governor would forfeit their salary and reimbursement for travel or living expenses from the day immediately following the date on which the Controller makes the determination until the date on which a budget bill is enacted.	01/07/2026: INTRODUCED.
CA ACR 161 (Addis (D))	Special Districts Week	Support	Proclaims the week of April 5, 2026, to April 11, 2026, to be Special Districts Week.	05/05/2026: In SENATE. To Special Consent Calendar.
CA SB 33 (Cortese (D))	Public Contracts: Claim Resolution		Provides that existing law prescribes various requirements regarding the formation, content, and enforcement of state and local public contracts. Provides that existing law establishes, until January 1, 2027, for contracts entered into on or after January 1, 2017, a claim resolution process applicable to any claim by a contractor in connection with a public works project against a public entity. Repeals January 1, 2027, repeal date, thereby extending the operation of these provisions indefinitely.	01/26/2026: In SENATE. Read third time. Passed SENATE. *****To ASSEMBLY.
CA SB 52 (Perez S (D))	Housing Rental Terms: Algorithmic Devices		Makes it unlawful for any person to sell, license, or provide to a certain number or more persons a rental pricing algorithm with the intent or reasonable expectation that it be used by a specified	08/29/2025: In ASSEMBLY Committee on APPROPRIATIONS: Held in committee.

## IRWD 2024 LEGISLATIVE MATRIX

Updated: May 6, 2026

Bill No. Author	Title	IRWD Position	Summary/Effects	Status
			number or more persons to set rental terms for residential premises. Makes it unlawful for a person to set or adopt rental terms based on the recommendation of a rental pricing algorithm if the person knows or should know that the rental pricing algorithm processes nonpublic competitor data for certain purposes.	
<b>CA SB 58</b> (Padilla (D))	Air Quality: Standard: Hydrogen Sulfide		Requires the State Air Resources Board to adopt standards of ambient air quality for each air basin in consideration of the public health, safety, and welfare, including, but not limited to, health, illness, irritation to the senses, aesthetic value, interference with visibility, and effects on the economy. Requires the Office of Environmental Health Hazard Assessment to develop health-based threshold levels for hydrogen sulfide.	01/26/2026: In SENATE. Read third time. Passed SENATE. *****To ASSEMBLY.
<b>CA SB 73</b> (Cervantes (D))	Elections: Inspection of Voting Systems		Requires an elections official to immediately notify the Secretary of State and the Attorney General when a court order related to the search or seizure of a voting system or other specified records, software or materials, is being executed. Prohibits a peace officer from interfering with the administration of an election from establishing or attempting to establish the qualifications of voters, or from imposing rules, standards, or practices contrary to state elections law.	05/06/2026: From ASSEMBLY Committee on PUBLIC SAFETY: Do pass as amended to Committee on APPROPRIATIONS.
<b>CA SB 74</b> (Seyarto (R))	Office of Land Use and Climate Innovation		Requires the Office of Land Use and Climate Innovation to establish the Infrastructure Gap Fund Program to provide grants to local agencies for the development and construction of infrastructure projects facing unforeseen costs after starting construction. Authorizes the office to provide funding for up to a specified percent of a project's additional projected cost after the project has started construction, subject to specified conditions. Relates to the allocation of existing local tax revenue.	08/29/2025: In ASSEMBLY Committee on APPROPRIATIONS: Held in committee.

## IRWD 2024 LEGISLATIVE MATRIX

Updated: May 6, 2026

Bill No. Author	Title	IRWD Position	Summary/Effects	Status
CA SB 234 (Niello (R))	Wildfires: Workgroup: Toxic Heavy Metals		Requires the Department of Forestry and Fire Protection, the Office of Emergency Services, and the Department of Toxic Substances Control to form a workgroup related to exposure to toxic heavy metals after a wildfire. Requires the workgroup to establish best practices and recommendations for wildfire impacted communities. Requires the departments to report their findings to the Legislature not more than a specified number of years after the convening of the first meeting of the workgroup.	08/29/2025: In ASSEMBLY Committee on APPROPRIATIONS: Held in committee.
CA SB 238 (Smallwood-Cueva (D))	Workplace Surveillance Tools		Requires an employer to annually provide a notice to the Department of Industrial Relations, in the Labor and Workforce Development Agency, of all the workplace surveillance tools the employer is using in the workplace. Requires the notice to include, among other information, the personal information that will be collected from workers and consumers and whether they will have the option of opting out of the collection of personal information.	07/16/2025: In ASSEMBLY Committee on PRIVACY AND CONSUMER PROTECTION: Not Heard.
CA SB 239 (Arreguin (D))	Open Meetings: Teleconferencing: Subsidiary Body		Provides that the Ralph M. Brown Act requires that all meetings of a legislative body be open and public and that all persons be permitted to attend and participate. Authorizes a subsidiary body to use alternative teleconferencing provisions and imposes requirements for notice, agenda, and public participation. Requires the subsidiary body to post the agenda at each physical meeting location designated by the subsidiary body.	01/27/2026: In SENATE. Read third time. Passed SENATE. *****To ASSEMBLY.
CA SB 247 (Smallwood-Cueva (D))	State Agency Contracts: Bid Preference: Equity Metrics		Relates to bid preferences and participation goals in public contracting for certain types of bidders. Relates to the Small Business Procurement and Contract Act and the State Disabled Veteran Business Enterprise Program. Requires an awarding department, defined to include a State agency or department, to provide a bid preference of a prescribed percentage in the award of contracts to contractors that set equity metrics.	01/27/2026: In SENATE. Read third time. Passed SENATE. *****To ASSEMBLY.

## IRWD 2024 LEGISLATIVE MATRIX

Updated: *May 6, 2026*

Bill No. Author	Title	IRWD Position	Summary/Effects	Status
CA SB 256 (Perez S (D))	Electricity: Electrical Infrastructure: Wildfire		Requires certain electrical corporations and local publicly owned electric utilities, in cooperation with the Office of Emergency Services and other emergency service agencies, to establish procedures for the coordination of efforts between electrical corporations and local publicly owned electric utilities and their representatives and emergency response agencies. Requires these corporations and electric utilities to assign liaison representatives to work in each local operations center.	08/29/2025: In ASSEMBLY Committee on APPROPRIATIONS: Held in committee.
CA SB 288 (Seyarto (R))	Property Taxation: Change In Ownership: Family Homes		Relates to property taxes for family homes and farms. Provides that, in the event of a transfer to an eligible transferee as a result of the death of an eligible transferor by an order entered pursuant to specified existing law, the specified one-year periods shall be deemed to commence as of the effective date of the order.	05/04/2026: To ASSEMBLY Committee on REVENUE AND TAXATION.
CA SB 401 (Hurtado (D))	Political Reform Act: Filing Deadlines		Authorizes the Fair Political Practices Commission to extend any filing deadline established by the act for individuals that live in an area impacted by an emergency situation. Defines emergency situation to mean an emergency proclaimed by the Governor or a local governing body pursuant to a specified law.	05/04/2026: To ASSEMBLY Committee on ELECTIONS.
CA SB 420 (Padilla (D))	Automated Decision Systems		Requires a developer or a deployer of a high-risk automated decision system to perform an impact assessment before making it publicly available or deploying it. Authorizes the Attorney General or the Civil Rights Department to allow a developer or deployer to cure certain violations. Prohibits an agency from awarding a contract for a high-risk automated decision system unless the person to whom the contract is awarded has certified that the system does not violate, among other civil rights laws, this bill.	06/09/2025: To ASSEMBLY Committees on PRIVACY AND CONSUMER PROTECTION and JUDICIARY.
CA SB 431 (Arreguin (D))	Assault and Battery: Utility Workers		Makes an assault or battery committed against a utility worker who is engaged in the performance of their duties punishable by imprisonment in a county jail not exceeding a specified term, by a	08/29/2025: In ASSEMBLY Committee on APPROPRIATIONS: Held in committee.

## IRWD 2024 LEGISLATIVE MATRIX

Updated: *May 6, 2026*

Bill No. Author	Title	IRWD Position	Summary/Effects	Status
			fine not exceeding a specified amount, or by both that fine and imprisonment.	
<b>CA SB 436</b> (Wahab (D))	Unlawful Detainer: Notice to Terminate Tenancy		Provides that existing law prescribes summary procedures for actions to obtain possession of real property. Provides that existing law authorizes a landlord to serve a notice of termination of tenancy on a tenant who is in default in the payment of rent. Extends the notice period to terminate a tenancy on a tenant who is in default in the payment of rent to permit the tenant at least a specified number of days, excluding weekends and judicial holidays, to pay the amount that is in default and due.	06/24/2025: In ASSEMBLY Committee on JUDICIARY: Reconsideration granted.
<b>CA SB 445</b> (Wiener (D))	High-Speed Rail: Third-Party Permits and Approvals		Requires the authority, on or before July 1, 2026, to develop and adopt internal rules, as defined, setting forth standards and timelines for the authority to engage utilities to ensure coordination and cooperation in relocating utility infrastructure or otherwise resolving utility conflicts affecting the delivery of the high-speed rail project.	08/29/2025: In ASSEMBLY Committee on APPROPRIATIONS: Held in committee.
<b>CA SB 457</b> (Becker (D))	Housing Element Compliance: Committed Assistance		Provides that the Planning and Zoning Law require each county and each city to adopt a general plan that includes a housing element. Provides that existing law requires that the housing element, among other things, sets forth a schedule of actions during the planning period that the local government is undertaking or intends to undertake to implement the policies and achieve the goals of the housing element. Defines in-kind services.	01/26/2026: In SENATE. Read third time. Passed SENATE. *****To ASSEMBLY.
<b>CA SB 473</b> (Padilla (D))	Water Corporations: Demand Elasticity: Rates		Relates to rates for water service. Requires that any changes to rates or implementation of surcharges on the Public Utilities Commission to ensure errors in estimates of demand elasticity or sales do not result in material overcollections or undercollections of water corporations do not result in revenues above those approved by the commission.	08/29/2025: In ASSEMBLY Committee on APPROPRIATIONS: Held in committee.

## IRWD 2024 LEGISLATIVE MATRIX

Updated: *May 6, 2026*

Bill No. Author	Title	IRWD Position	Summary/Effects	Status
<b>CA SB 522</b> (Wahab (D))	Housing: Tenant Protections		Provides that the Tenant Protection Act of 2019 prohibits an owner of residential real property from terminating the tenancy of certain tenants without just cause. Excludes housing built to replace a previous housing unit that was subject to the Tenant Protection Act, was substantially damaged or destroyed by a disaster, and was issued a certificate of occupancy before that housing unit was substantially damaged or destroyed, from the exemption from the just cause requirements.	09/10/2025: In ASSEMBLY. To Inactive File.
<b>CA SB 526</b> (Menjivar (D))	South Coast Air Quality Management District: Air		Provides that existing law provides for the creation of the South Coast Air Quality Management District in portions of the specified counties included in the South Coast Air Basin. Requires the South Coast District Board to update Rule 1157 to improve air quality and increase data collection. Requires the owner or operator of a covered facility to take specified actions. Makes legislative findings and declarations as to the necessity of a special statute for the South Coast District.	06/16/2025: To ASSEMBLY Committee on NATURAL RESOURCES.
<b>CA SB 555</b> (Caballero (D))	Workers' Compensation: Average Annual Earnings		Relates to the workers' compensation system. Provides that existing law requires, for computing average annual earnings for purposes of permanent partial disability indemnity, that average weekly earnings be taken at various amounts, including between the specified amounts for injuries occurring on or after the specified date. Requires that for computing average annual earnings for purposes of permanent partial disability indemnity, average weekly earnings be taken occurring on or after January 1, 2027.	05/04/2026: To ASSEMBLY Committee on INSURANCE.
<b>CA SB 556</b> (Hurtado (D))	Habitat Enhancement and Restoration: Floodplains		Provides that under existing law, the Wildlife Conservation Board administers various habitat conservation and restoration programs. Requires, upon appropriation by the Legislature, the specified sum to be allocated to the Wildlife Conservation Board for floodplain acquisition, habitat restoration, and associated	08/29/2025: In ASSEMBLY Committee on APPROPRIATIONS: Held in committee.

## IRWD 2024 LEGISLATIVE MATRIX

Updated: *May 6, 2026*

Bill No. Author	Title	IRWD Position	Summary/Effects	Status
			conservation projects on floodplains in the Counties of Kern, Kings, and Tulare.	
<b>CA SB 599</b> (Caballero (D))	Atmospheric Rivers: Research: Forecasting Methods	Support	Relates to the Atmospheric Rivers Research and Forecast Improvement Program: Enabling Climate Adaptation Through Forecast-Informed Reservoir Operations and Hazard Resiliency Program in the Department of Water Resources. Provides that existing law requires the department to operate reservoirs in a manner that improves flood protection. Requires, for certain novel forecasting methods, the department to include the use of experimental tools that produce seasonal and subseasonal atmospheric river forecasts.	09/10/2025: In ASSEMBLY. To Inactive File.
<b>CA SB 601</b> (Allen (D))	Water: Waste Discharge		Authorizes the State Water Resources Control Board to adopt water quality control plans for nexus waters. Requires any water quality standard that was submitted to the U.S. Environmental Protection Agency or the State Board that applied to nexus waters as of the specified date to remain in effect. Requires certain discharge requirements to, in the case of discharges from any point source to nexus waters, implement certain requirements for implementing the Federal Water Pollution Control Act.	08/29/2025: In ASSEMBLY Committee on APPROPRIATIONS. Held in committee and made a Two-year bill.
<b>CA SB 677</b> (Wiener (D))	Housing Development: Transit-oriented Development		Revises the definition of high-frequency commuter rail to instead mean a public commuter or intercity rail station with a total of at least 48 passenger trains on average per weekday across all directions, not including temporary service changes of less than one month or unplanned disruptions, and not meeting the standard for very high frequency commuter rail, at any point in the past three years.	01/26/2026: In SENATE. Read third time. Passed SENATE. *****To ASSEMBLY.
<b>CA SB 715</b> (Allen (D))	Regional Housing Need: Methodology: Distribution		Provides that the Planning and Zoning Law requires the Department of Housing and Community Development to determine the existing and projected need for housing for each region and requires the appropriate council of governments to	06/05/2025: To ASSEMBLY Committees on HOUSING AND COMMUNITY DEVELOPMENT and LOCAL GOVERNMENT.

## IRWD 2024 LEGISLATIVE MATRIX

Updated: *May 6, 2026*

Bill No. Author	Title	IRWD Position	Summary/Effects	Status
			adopt a final regional housing need plan. Removes the requirement that the loss of units factor due to a declared emergency be considered. Requires those lost units to be distributed proportionally according to the region's proposed methodology.	
CA SB 722 (Wahab (D))	Transit-oriented Housing Development		Prohibits a housing development from being located on an existing parcel of land or site governed under the Mobilehome Residency Law, the Recreational Vehicle Park Occupancy Law, the Mobilehome Parks Act, or the Special Occupancy Parks Act.	05/04/2026: To ASSEMBLY Committees on HOUSING AND COMMUNITY DEVELOPMENT and LOCAL GOVERNMENT.
CA SB 724 (Richardson (D))	Public Housing: Lead Testing		Requires the owner of a public housing unit that is owned or managed by a city, county, city and county, or city, county, or city and county housing authority, to provide information to the residents of the public housing unit regarding any applicable existing program that offers free testing of the water for lead.	08/29/2025: In ASSEMBLY Committee on APPROPRIATIONS: Held in committee.
CA SB 741 (Blakespear (D))	Coastal Resources: Coastal Development Permit		Relates to the California Coastal Act of 1976. Provides that existing law exempts from the coastal development permitting process certain emergency projects undertaken, carried out, or approved by a public agency to maintain, repair, or restore existing highways. Expands that exemption to include certain emergency projects undertaken, carried out, or approved by a public agency to maintain, repair, or restore existing railroad track along the Los Angeles-San Diego-San Luis Obispo Rail Corridor.	06/05/2025: To ASSEMBLY Committee on NATURAL RESOURCES.
CA SB 742 (Perez S (D))	Electricity: Electrical Infrastructure		Requires the Public Utilities Commission to update a general order to require each electrical corporation to remove all permanently abandoned transmission facilities. Requires that an electrical corporation's wildfire mitigation plan also include an accounting of all transmission facilities, including permanently abandoned transmission facilities, and include a plan for how and when each permanently abandoned transmission facility will be removed.	05/04/2026: To ASSEMBLY Committee on UTILITIES AND ENERGY.

## IRWD 2024 LEGISLATIVE MATRIX

Updated: *May 6, 2026*

Bill No. Author	Title	IRWD Position	Summary/Effects	Status
<b>CA SB 747</b> (Wiener (D))	Civil Rights		Provides that every person who, under color of any law, statute, ordinance, regulation, custom, or usage, as defined, subjects or causes to be subjected any citizen of this state or any person within the jurisdiction thereof to the deprivation of any rights, privileges, or immunities secured by the United States Constitution, shall be liable to the party injured in an action at law, suit in equity, or other proper proceeding for redress.	05/04/2026: To ASSEMBLY Committee on JUDICIARY.
<b>CA SB 833</b> (McNerney (D))	Critical Infrastructure: Automated Decision Systems		Provides that existing law requires the Technology Recovery Plan element of the State Administrative Manual to ensure the inclusion of cybersecurity strategy incident response standards. Requires an operator responsible for operating, managing, overseeing, or controlling access to critical infrastructure, that deploys a covered artificial intelligence (AI) system to establish a human oversight mechanism that ensures a human monitors the system's operations in real time.	08/29/2025: In ASSEMBLY Committee on APPROPRIATIONS. Held in committee and made a Two-year bill.
<b>CA SB 842</b> (Stern (D))	Energy: Firm Zero Carbon Resources		Requires the Public Utilities Commission to produce a report identifying opportunities and needs to provide for local and system reliability with firm zero-carbon resources over the short term, midterm, and long term. Requires the report to include, among other things, characterization of the resource attributes vital for local and system reliability and identification of barriers, including market barriers, to deploying firm zero-carbon resources to enhance local reliability.	08/29/2025: In ASSEMBLY Committee on APPROPRIATIONS: Held in committee.
<b>CA SB 872</b> (McNerney (D))	Delta Levees and Canal Subsidence Fund	Support	Establishes the Delta Levees and Canal Subsidence Fund. Authorizes the Secretary of the Natural Resources Agency to seek out, and the fund to accept, State moneys from, among other sources, any bond funds, the General Fund, or the Greenhouse Gas Reduction Fund. Requires the Sacramento San Joaquin Delta Conservancy, before expending funds for any project in the Delta or Suisun Marsh, to prepare an annual spending plan. Requires	04/27/2026: In SENATE Committee on APPROPRIATIONS: To Suspense File.

## IRWD 2024 LEGISLATIVE MATRIX

Updated: *May 6, 2026*

Bill No. Author	Title	IRWD Position	Summary/Effects	Status
			the governing board of the conservancy to approve the plan. Appropriates funds.	
<b>CA SB 875</b> (Wiener (D))	Public Utilities: Eminent Domain: Just Compensation		Provides that existing law provides procedures for the acquisition under eminent domain proceedings of lands, property, and rights of a public utility by a political subdivision. Requires the owner of a public utility, within a specified number of days of a subdivision submitting an amount for just compensation or a plan for the separation of the utility's assets, to submit an amount for just compensation or provide a response to the separation plan.	04/21/2026: In SENATE Committee on ENERGY, UTILITIES AND COMMUNICATIONS: Failed passage.
<b>CA SB 879</b> (Laird (D))	Budget Act of 2026		Makes appropriations for the support of state government for the 2026-27 fiscal year.	01/09/2026: INTRODUCED.
<b>CA SB 880</b> (Wahab (D))	Residential Property: Contract: Fees		Provides that existing law prohibits the vendor or lessor of a single family residential property from contracting for or exacting any fee in excess of a specified amount for the act of signing and delivering a document in connection with the transfer, cancellation, or reconveyance of any title or instrument at the time the buyer or lessee exercises an option to buy the property. Extends that prohibition to the vendor or lessor of any residential property.	04/30/2026: In SENATE. Read second time. To Consent Calendar.
<b>CA SB 884</b> (Umberg (D))	Elections in 2026 through 2029		Requires, for any regular or special election beginning with the specified election held in the specified years or proclaimed in the specified year, all counties to provide at least a specified number of ballot dropoff locations or at least one location for every specified number of voters. Prohibits law enforcement officers from making arrests within a specified distance of a polling place on election day, except for a crime related to disrupting the polling place or a crime against a person or property.	05/04/2026: In SENATE Committee on APPROPRIATIONS: To Suspense File.

## IRWD 2024 LEGISLATIVE MATRIX

Updated: May 6, 2026

Bill No. Author	Title	IRWD Position	Summary/Effects	Status
CA SB 885 (Strickland (R))	Restoring Accountability Act: Major Regulations		Provides for the Restoring Accountability Act. Prohibits a State agency from taking final action to adopt a major regulation until certain requirements are met. Authorizes a State agency to adopt an emergency regulation that is a major regulation if the State agency complies with specified requirements governing the adoption of emergency regulations.	04/14/2026: In SENATE Committee on GOVERNMENTAL ORGANIZATION: Reconsideration granted.
CA SB 886 (Padilla (D))	California Technology Innovation and Ratepayer		Provides for the State Technology Innovation and Ratepayer Protection Act. Requires the Public Utilities Commission to establish a rate structure that includes an electrical corporation tariff for the interconnection of the participating customer facilities and the provision of transmission, distribution, and generation services to participating customers. Requires the commission, as part of establishing the electrical corporation tariff, to, among other things, establish eligibility criteria.	04/13/2026: In SENATE Committee on APPROPRIATIONS: To Suspend File.
CA SB 887 (Padilla (D))	California Environmental Quality Act: Environmental		Authorizes the Governor to certify a geothermal powerplant that meets certain criteria as an environmental leadership development project. Requires the quantification and mitigation of impacts for emissions of greenhouse gases of a data center project in the same manner as certain environmental leadership projects.	05/04/2026: In SENATE Committee on APPROPRIATIONS: To Suspend File.
CA SB 894 (Allen (D))	Wildfire Resiliency: Financial Assistance		Requires the Office of Emergency Services to enter into a joint powers agreement, as specified, with the Department of Forestry and Fire Protection to develop and administer a comprehensive wildfire mitigation program, that, among other things, encourages cost-effective structure hardening and retrofitting that creates fire-resistant homes, businesses, and public buildings.	04/23/2026: In SENATE. Read second time and amended. Re-referred to Committee on APPROPRIATIONS.
CA SB 898 (Weber (D))	Connected Consumer Products		Requires that a minimum guaranteed support timeframe be no less than 5 years, as specified. Defines connected consumer product to mean a physical product, as specified, that is intended for consumer use and depends, partly or in whole, on an internet connection. Defines end of life to mean the point after which the	05/05/2026: In SENATE. Read second time and amended. Re-referred to Committee on APPROPRIATIONS.

## IRWD 2024 LEGISLATIVE MATRIX

Updated: *May 6, 2026*

Bill No. Author	Title	IRWD Position	Summary/Effects	Status
			manufacturer no longer provides necessary support or updates for a connected consumer product.	
<b>CA SB 899</b> (Grove (R))	Fire Prevention: Wildfire and Forest Resilience		Provides that existing law requires the Wildfire and Forest Resilience Task Force to develop a comprehensive implementation strategy to track and ensure the achievement of the goals and key actions identified in the States Wildfire and Forest Resilience Action Plan. Requires the task force, in cooperation with the Office of Environmental Health Hazard Assessment and the State Department of Public Health, to assess the health costs and impacts of wildfire smoke using existing wildfire smoke and health data.	05/04/2026: In SENATE Committee on APPROPRIATIONS: To Suspense File.
<b>CA SB 900</b> (McNerney (D))	Political Reform Act of 1974: Top Contributors		Requires the disclosure of information related to political advertisements, including the name of the committee that paid for the advertisement and the names of the 3 top contributors to the committee. Defines top contributor as the persons from whom the committee paying for an advertisement has received its three highest cumulative contributions of a specified amount or more. Requires an advertisement to include the disclosure and be separated from any disclosures that follow by at least half a blank line.	05/04/2026: In SENATE Committee on APPROPRIATIONS: To Suspense File.
<b>CA SB 904</b> (Seyarto (R))	California Emergency Services Act: Disaster Recovery		Requires the Department of Housing and Community Development, in consultation with other specified State agencies, within a specified number of days of a state of emergency declared by the Governor relating to a wildfire, to provide a report to the Governor and the Legislature identifying State permitting requirements that may unduly impede efforts to rebuild properties or facilities destroyed as a result of the wildfire that should be considered for suspension.	04/27/2026: In SENATE Committee on APPROPRIATIONS: To Suspense File.

## IRWD 2024 LEGISLATIVE MATRIX

Updated: *May 6, 2026*

Bill No. Author	Title	IRWD Position	Summary/Effects	Status
<b>CA SB 909</b> (Smallwood-Cueva (D))	Public Works		Exempts the establishment and adjustment of specified fees from the Administrative Procedure Act and would remove the \$800 fee limit to establish and adjust annual registration and renewal fees.	04/27/2026: In SENATE Committee on APPROPRIATIONS: To Suspend File.
<b>CA SB 910</b> (Seyarto (R))	Municipal Water Districts: Water Service: Indian Lands		Extends provisions of the Municipal Water District Law of 1911, regarding the application to the applicable local agency formation commission concerning Indian Lands to January 1, 2032.	03/18/2026: In SENATE Committee on LOCAL GOVERNMENT: Not heard.
<b>CA SB 911</b> (Becker (D))	Transfer of Real Property: Fire Hazard Severity Zones		Provides that existing law requires a seller of a real property that is located in a high or very high fire hazard severity zone to provide to the buyer certain documentation. Authorizes a local fire department to prioritize compliance inspections and reinspections based on certain factors. Provides that a local fire department is authorized to recover the costs of compliance inspections and reinspections. Provides that certain provisions do not modify the immunities granted to a local fire department.	05/04/2026: In SENATE Committee on APPROPRIATIONS: To Suspend File.
<b>CA SB 919</b> (Grayson (D))	Biomethane Projects: Investment Costs		Requires the Public Utilities Commission to extend the Biomethane Monetary Incentive Program. Authorizes the commission to authorize additional funding for the program, of which no more than \$10,000,000 would be authorized for dairy biomethane projects, using the revenues, including any accrued interest, received by a gas corporation as a result of the direct allocation of greenhouse gas allowances provided to gas corporations as part of the above-described market-based compliance mechanism.	04/28/2026: In SENATE. Read second time and amended. Re-referred to Committee on APPROPRIATIONS.
<b>CA SB 922</b> (Laird (D))	Vehicles: Local Agency Charges: Use of Streets		Provides that existing law prohibits a local agency from imposing a tax, permit fee, or other charge for the privilege of using its streets or highways, other than a permit fee for an extralegal load unless the local agency had imposed the fee prior to the specified date. Limits this prohibition to charges based on weight. Provides	03/19/2026: In SENATE. Read second time. To third reading.

**IRWD 2024 LEGISLATIVE MATRIX**

Updated: *May 6, 2026*

Bill No. Author	Title	IRWD Position	Summary/Effects	Status
			that nothing in the Vehicle Code prohibits a local agency from imposing or collecting this fee, charge, or surcharge.	
CA SB 923 (Becker (D))	Consumer Privacy Requests: Deletion Request Records		Provides that the California Consumer Privacy Act of 2018 grants to a consumer the right to request that a business delete personal information that the business has collected from the consumer. Expands that right to include requesting the deletion of any personal information that the business has collected about the consumer. Allows, if the business did not obtain the personal information from the consumer, the business to retain a record of the deletion request and certain data.	04/20/2026: In SENATE Committee on APPROPRIATIONS: To Suspense File.
CA SB 924 (Hurtado (D))	Low Income Energy Assistance		Amends specified section of Public Utilities Code, relating to energy. Requires the commission to take into consideration the cost-effectiveness of the services as a whole. Authorizes the commission to consider nonenergy benefits when establishing priorities for program design. Requires the commission to ensure that weatherization program costs do not result in undue cost burdens for ratepayers. Ensures that diverse contracting requirements are consistent with specified plans submitted to the commission.	05/04/2026: In SENATE Committee on APPROPRIATIONS: To Suspense File.
CA SB 935 (Choi (R))	Local Agency Design-Build Projects: Authorization		Repeals the repeal date of local agency design-build projects, authorization, thereby extending the operations of those provisions indefinitely.	05/04/2026: To ASSEMBLY Committee on LOCAL GOVERNMENT.
CA SB 943 (Becker (D))	Public Utilities: Electricity: Transmission Charge		Establishes as a policy of the State that allocation of costs to ratepayers for transmission and distribution resources should follow cost causation principles. Requires the Public Utilities Commission to request the Independent System Operator to reconsider issues raised in its transmission access charge structure enhancements proceeding as potential reforms to its high voltage transmission access charges.	04/13/2026: In SENATE Committee on APPROPRIATIONS: To Suspense File.

## IRWD 2024 LEGISLATIVE MATRIX

Updated: *May 6, 2026*

Bill No. Author	Title	IRWD Position	Summary/Effects	Status
CA SB 947 (McNerney (D))	Employment: Automated Decision Systems		Requires an employer that primarily relied upon an ADS to make a disciplinary, termination, or deactivation decision to provide the affected worker with a written postuse notice, as specified.	05/04/2026: In SENATE Committee on APPROPRIATIONS: To Suspense File.
CA SB 951 (Reyes (D))	Employment: Technological Displacement: Notice		Requires an employer to provide a written technology hiring disruption notice to the Employment Development Department and the local workforce investment board when it executes a technological cessation in hiring directly and primarily due to the adoption of artificial intelligence or other automating technology. Imposes various reporting requirements on the Employment Development Department.	05/04/2026: In SENATE Committee on APPROPRIATIONS: To Suspense File.
CA SB 952 (Laird (D))	State Water Project: Renewable Energy Resources		Provides that existing law requires the Department of Water Resources to procure eligible renewable energy resources and zero carbon resources to satisfy specified obligations imposed on the State Water Resources Development System, commonly known as the State Water Project. Requires the department, in conducting procurement, to consider portfolio diversity, resource type, location, and hours of typical peak operation.	04/28/2026: In SENATE. Read second time. To third reading.
CA SB 954 (Blakespear (D))	California Environmental Quality Act: Advanced		Provides that certain exemptions from the California Environmental Quality Act regarding rezoning do not apply to rezoning that authorizes a tourism facility use that was not permitted before the rezoning or authorizes an increase in the allowable floor area, height, density, intensity, or development capacity of a tourism facility use beyond that permitted under the sites zoning designation in effect before the rezoning or before the specified date, with certain exceptions.	05/04/2026: In SENATE Committee on APPROPRIATIONS: To Suspense File.
CA SB 962 (Archuleta (D))	Emergency Vehicles: Blue Warning Lights		Provides for the Agent Joshua Byrd Memorial Act. Authorizes parole officers to display a blue warning light from their emergency vehicles if they complete a specified classroom training course regarding the operation of emergency vehicles	04/27/2026: In SENATE Committee on APPROPRIATIONS: To Suspense File.

## IRWD 2024 LEGISLATIVE MATRIX

Updated: *May 6, 2026*

Bill No. Author	Title	IRWD Position	Summary/Effects	Status
			that is certified by the Commission on Correctional Peace Officer Standards and Training.	
<b>CA SB 963</b> (Laird (D))	California Coastal Act of 1976: Coastal Development		Requires an appeal of an action by a local government on a coastal development permit application to be considered properly submitted if the appealing party or parties submit a completed, signed copy of the appeal form provided by the State Coastal Commission within the applicable timeline. Requires the commission to provide for de novo review and a public hearing on the coastal development permit application if the commission determines that a substantial issue exists.	04/30/2026: In SENATE. Read third time. Passed SENATE. *****To ASSEMBLY.
<b>CA SB 978</b> (Perez S (D))	Data Centers: Labor: Electricity Rates		Requires the Public Utilities Commission to establish a special rate structure for data centers taking transmission level electrical service with an estimated peak demand of at least a specified number of megawatts of electricity to, among other things, protect other customers of electrical corporations, prohibit cost shifts to those other customers, and require data centers to pay for the electrical corporations upfront costs of transmission or necessary distribution infrastructure upgrades.	04/20/2026: In SENATE Committee on APPROPRIATIONS: To Suspend File.
<b>CA SB 979</b> (Strickland (R))	Planning and Zoning: Housing Element: Regional Housing		Provides that the final determination by the council of governments or the delegate subregion is subject to judicial review, as specified. Relates to the housing element, a regional housing needs allocation and judicial reviews.	04/07/2026: In SENATE Committee on HOUSING: Not heard.
<b>CA SB 981</b> (Niello (R))	Administrative Regulations: Standardized Regulatory		Provides that existing law designates the State Air Resources Board as the agency responsible for the preparation of the State implementation plan required by the Clean Air Act. Requires a standardized regulatory impact analysis prepared by the board to address cost of living impacts on residents of the State, including, but not limited to, retail gasoline and transportation costs, consumer electric bills, consumer goods and food costs, housing and building construction costs, and costs to businesses.	05/04/2026: In SENATE Committee on APPROPRIATIONS: To Suspend File.

## IRWD 2024 LEGISLATIVE MATRIX

Updated: *May 6, 2026*

Bill No. Author	Title	IRWD Position	Summary/Effects	Status
CA SB 986 (Seyarto (R))	Major Regulations		Relates to the Administrative Procedure Act. Prohibits a major regulation from taking effect until submission to, and expiration of a specified review period by, the Legislature, except for emergency regulations. Requires, prior to the expiration of the review period, the Legislature to hold an informational hearing on the major regulation. Authorizes the Legislature to reject a major regulation during the review period by adoption of a concurrent resolution.	04/27/2026: In SENATE Committee on APPROPRIATIONS: To Suspend File.
CA SB 1001 (Archuleta (D))	Local Agency, Public Utility, or Mutual Water Company:	Oppose Unless Amended	Requires the Office of Emergency Services, upon request, to issue a local agency, public utility, or mutual water company responsible for public works and critical infrastructure with specified credentialing to facilitate personnel access to an area during or following a natural disaster, act of terrorism, or other manmade disaster. Specifies that the credentialing, a Personal Identity Verification Interoperable, would conform with the federal Personal Identity Verification standards.	04/27/2026: In SENATE Committee on APPROPRIATIONS: To Suspend File.
CA SB 1036 (Grayson (D))	Mitigation Fee Act		Relates to development project fees. Provides that when a change in the capacity of an existing water or sewer connection is proposed, a local agency, in calculating the estimated reasonable cost of a capacity charge, shall only calculate an amount attributable to the change in the capacity. Prohibits, if the existing capacity exceeds the proposed capacity, any amount from being refunded, credited, transferred, assigned, or otherwise applied to offset any other charge or fee.	04/27/2026: In SENATE. Read third time. Passed SENATE. *****To ASSEMBLY.
CA SB 1064 (Dahle M (R))	Heavy-Duty Vehicle Inspection and Maintenance Program		Limits specified testing of all non-gasoline heavy-duty on road motor vehicles with a gross vehicle weight rating of more than 14,000 pounds that are considered low use, as defined too not more frequently than annually. Requires the state board to adopt rules and regulations to implement this provision.	04/23/2026: In SENATE. Read second time and amended. Re-referred to Committee on APPROPRIATIONS.

## IRWD 2024 LEGISLATIVE MATRIX

Updated: May 6, 2026

Bill No. Author	Title	IRWD Position	Summary/Effects	Status
CA SB 1068 (Alvarado-Gil (R))	Water Appropriations		Makes a nonsubstantive change to existing law which requires the State Water Resources Control Board to consider and act upon all applications for permits to appropriate water.	02/26/2026: To SENATE Committee on RULES.
CA SB 1075 (Reyes (D))	Air Resources: Toxic Air Contaminants: Criteria		Requires a city, including a charter city, or a county for which an approved community emissions reduction program or local community emissions reduction plan has been prepared, before approving a commercial or industrial development located on a site of 5 acres or more, to consider the community emissions reduction program or local community emissions reduction plan, or both program and plan.	04/23/2026: In SENATE. Read second time and amended. Re-referred to Committee on APPROPRIATIONS.
CA SB 1081 (Laird (D))	Waste Discharge Requirements: Minimum Penalties		Provides that the Porter Cologne Water Quality Control Act requires mandatory minimum penalties to be assessed for serious violations relating to waste discharge requirements. Expands the authorization for the State Water Resources Control Board or regional board to require funding of a compliance project in lieu of the otherwise mandatory penalty to apply to a publicly owned treatment works serving a population of a certain number of persons or fewer within a certain number of years preceding the penalty.	04/27/2026: In SENATE Committee on APPROPRIATIONS: To Suspend File.
CA SB 1085 (Durazo (D))	Water Supply Planning: Housing Developments	Support	Requires, among other things a city or county, upon receipt of a preliminary application for a housing development project that meets certain conditions, or upon a development application for certain projects complete, being determined as complete or deemed complete, to make that identification of public water systems.	04/23/2026: In SENATE. Read second time and amended. Re-referred to Committee on APPROPRIATIONS.
CA SB 1117 (Cervantes (D))	Accessory Dwelling Units and Junior Accessory Unit		Requires a charge under the Planning and Zoning Law to be based only on the area in excess of 750 square feet of interior livable space.	05/05/2026: In SENATE. Read second time. To third reading.

## IRWD 2024 LEGISLATIVE MATRIX

Updated: *May 6, 2026*

Bill No. Author	Title	IRWD Position	Summary/Effects	Status
CA SB 1121 (Seyarto (R))	Vehicles: Commercial Electric Vehicle Safety		Requires the Office of Emergency Services, on or before January 1, 2028, to develop and post on its internet website an action plan for responding to electric commercial motor vehicle battery fires that covers specified topics, including best practices for reducing wildfire risk and mitigating the risk of battery reignition.	03/04/2026: To SENATE Committee on EMERGENCY MANAGEMENT.
CA SB 1123 (Wiener (D))	Administrative Procedure Act: Major Regulations		Requires an agency, in estimating the economic impact of adopting, amending, or repealing a regulation, to identify and calculate any offsetting benefits, impacts, or savings that might result directly or indirectly from that adoption, amendment, or repeal and factor those benefits, impacts, or savings into its economic impact estimate.	04/27/2026: In SENATE Committee on APPROPRIATIONS: To Suspense File.
CA SB 1125 (Menjivar (D))	Water Rate Assistance Program	Support	Establishes the Water Rate Assistance Program. Establishes the Water Rate Assistance Fund to provide water affordability assistance for residential water services to low income residential ratepayers. Requires the State Water Resources Control Board to take various actions in administering the fund, including, among other things, tracking and managing revenue in the fund separately from all other revenue. Requires the board to adopt guidelines for implementation of the program.	05/04/2026: In SENATE Committee on APPROPRIATIONS: To Suspense File.
CA SB 1132 (Smallwood-Cueva (D))	Workforce Development: Workplace Rights Training		Requires the California Workforce Development Board to develop a workplace rights curriculum in partnership with subject matter experts and would require the local boards to ensure provision of a workplace rights training consistent with that curriculum to individuals receiving services through the California workforce system.	04/13/2026: In SENATE Committee on APPROPRIATIONS: To Suspense File.
CA SB 1135 (Blakespear (D))	California Wildlife Coexistence Act		Requires the Department of Fish and Wildlife to establish the Wildlife Coexistence Program to manage and promote wildlife coexistence by conducting specified activities, including maintaining a statewide wildlife incident reporting tool. Renames the California Wolf Livestock Compensation Pilot Program to the	04/27/2026: In SENATE Committee on APPROPRIATIONS: To Suspense File.

## IRWD 2024 LEGISLATIVE MATRIX

Updated: May 6, 2026

Bill No. Author	Title	IRWD Position	Summary/Effects	Status
			Wolf Livestock Coexistence and Compensation Program and requires the department to establish the program to provide resources to eligible participants for purposes relating to wolves and livestock.	
CA SB 1139 (Laird (D))	Monterey Peninsula Water Management District		Provides that existing law prohibits the use of potable water for the irrigation of nonfunctional turf located on commercial, industrial, and institutional properties. Requires a person or entity to be subject to civil liability or penalties imposed by the Monterey Peninsula Water Management District pursuant to a locally adopted ordinance or policy. Authorizes the Monterey Peninsula Water Management District to enforce the provisions relating to the prohibition.	04/20/2026: In SENATE. Read third time. Passed SENATE. *****To ASSEMBLY.
CA SB 1145 (Grayson (D))	California Environmental Quality Act: Surplus Land		Exempts land that was or will be conveyed by the federal government to a local reuse authority in accordance with a military base closure and realignment from these requirements if certain conditions are met. Requires a local reuse authority, if it is a city or county, to include specified information relating to the development of residential units on conveyed land as part of their annual report relating to their general plan.	04/28/2026: In SENATE. Read second time and amended. Re-referred to Committee on APPROPRIATIONS.
CA SB 1149 (Durazo (D))	Employees: Bereavement Leave		Provides that existing law makes it an unlawful employment practice for an employer to refuse to grant a request by any employee to take up to a specified number of days of bereavement leave upon the death of a family member. Includes a designated person identified by the employee in the definition of family member and authorizes an employer to limit an employee to one designated person per specified period for purposes of these provisions relating to bereavement leave.	04/20/2026: In SENATE Committee on APPROPRIATIONS: To Suspense File.
CA SB 1153 (Caballero (D))	Disaster Preparedness: Urban Retail Water Suppliers	Support	Requires all urban retail water suppliers serving a high or very high fire hazard severity zone to include incident specific response procedures for wildfires as part of their disaster	04/28/2026: In SENATE. Read second time and amended. Re-referred to Committee on APPROPRIATIONS.

## IRWD 2024 LEGISLATIVE MATRIX

Updated: *May 6, 2026*

Bill No. Author	Title	IRWD Position	Summary/Effects	Status
			preparedness plans, including any applicable emergency response plan required by federal law. Requires these plans to include, among other things, mitigation actions, including actions, procedures, and equipment, that can obviate or significantly lessen the impact of a wildfire on the water system and drinking water supply.	
CA SB 1161 (Valladares (R))	Administrative Regulations: Economic Impact Analysis		Requires the State Air Resources Board, in proposing to adopt, amend, or repeal a regulation, to include an economic impact assessment or the standardized regulatory impact assessment, a distributional analysis of the costs, benefits, and net impacts on personal income across income levels, and an informative digest.	04/20/2026: In SENATE Committee on APPROPRIATIONS: To Suspense File.
CA SB 1175 (Rubio (D))	Lobbyist Registration and Termination		Provides that the Political Reform Act of 1974 requires individual lobbyists to prepare certifications for filing with the Secretary of State. Provides that if any change occurs in the information contained in a lobbyist certification, existing law requires the lobbyist to submit an amended certification or notice of termination to the lobbyist's lobbying firm or lobbyist employer. Requires the lobbyist to submit the amended certification or notice of termination directly to the Secretary of State.	04/08/2026: In SENATE. Read second time. To third reading.
CA SB 1180 (Allen (D))	Plastic Pollution Prevention and Packaging Producer		Establishes the California Plastic Pollution Mitigation Fund, which consists of all environmental mitigation surcharges, interest, penalties, and other amounts collected pursuant to the Plastic Pollution Prevention and Packaging Producer Responsibility Act. Requires each expenditure made upon appropriation from the fund to comply with specified requirements. Requires certain expenditures to achieve one or more specified purposes.	05/04/2026: In SENATE Committee on APPROPRIATIONS: To Suspense File.
CA SB 1184 (McGuire (D))	State Environmental Quality Act		States the intent of the Legislature to enact subsequent legislation relating to environmental quality.	02/26/2026: To SENATE Committee on RULES.

## IRWD 2024 LEGISLATIVE MATRIX

Updated: May 6, 2026

Bill No. Author	Title	IRWD Position	Summary/Effects	Status
<b>CA SB 1187</b> (Durazo (D))	Open Meetings: Majority		Defines majority for purposes of the Ralph M. Brown Act to mean the number of members of the legislative body equaling more than half of the total number of seats on the legislative body. Specifies that if a seat on the legislative body is vacant, that seat is to still be counted as a seat on the legislative body.	04/30/2026: In SENATE. Read second time. To Consent Calendar.
<b>CA SB 1196</b> (McNerney (D))	Accessory Dwelling Units and Junior Accessory Dwellings		Requires the Public Utilities Commission to determine the criteria for timely service for electrical customers to be energized, including, among other things, categories of timely electric service through energization, as specified. Requires the commission, by September 30, 2027, in a new or existing proceeding, to establish timelines for electrical corporations to respond to and process requests to energize accessory dwelling units and junior accessory dwelling units.	05/04/2026: In SENATE Committee on APPROPRIATIONS: To Suspend File.
<b>CA SB 1205</b> (Valladares (R))	Public Contracts: Retention: Architecture		Relates to public works contracts. Provides that existing law requires that retention proceeds withheld from payment by a public entity be released within a specified number of days after the date of completion of the work of improvement. Prohibits retention payments from exceeding a certain percent of the payment for contracts under design bid build entered into on or after the specified date between a public entity and an individual or legal entity permitted to practice architecture or engineering.	05/04/2026: In SENATE Committee on APPROPRIATIONS: To Suspend File.
<b>CA SB 1229</b> (Allen (D))	Coastal Resources: Coastal Development Permits		Provides that the California Coastal Act provides that a coastal development permit is not required for the replacement of any structure, other than a public works facility, destroyed by a disaster. Prohibits that exemption from applying to the replacement of a structure by an applicant who was not listed as the property owner of record immediately preceding the disaster if replacement would encroach upon an open space easement or deed restriction that has been recorded or offered for dedication.	04/21/2026: In SENATE. Read second time. To third reading.

## IRWD 2024 LEGISLATIVE MATRIX

Updated: May 6, 2026

Bill No. Author	Title	IRWD Position	Summary/Effects	Status
CA SB 1239 (Jones (R))	State Air Resources Board: Regulations		Requires the State Air Resources Board to also prepare and publish a supplemental standardized regulatory impact analysis if the proposed regulation is materially changed after release of the initial standardized regulatory impact analysis, as described, and before adoption, that updates the consumer cost analysis to reflect amendments made during the rulemaking process.	04/08/2026: In SENATE Committee on ENVIRONMENTAL QUALITY: Reconsideration granted.
CA SB 1243 (Durazo (D))	Unlawful Detainer: Tenant Protections		Provides for the Tenant Protections for Immigrant Families Act. Prohibits an owner of residential real property from initiating or continuing an unlawful detainer action to evict a tenant whose income, ability to obtain income, or financial support is impacted by immigration enforcement activities until no sooner than 90 days after the tenant or household member's detention-related hardship ends.	04/28/2026: In SENATE. Read second time and amended. Re-referred to Committee on APPROPRIATIONS.
CA SB 1248 (Cabaldon (D))	State Agencies: Automated Decision Systems		Imposes certain restrictions on the use of an automated decision system by a state agency to confer services, defined as, among other things, the issuance of professional licenses and provision of public benefits.	05/04/2026: In SENATE Committee on APPROPRIATIONS: To Suspend File.
CA SB 1258 (Wiener (D))	Hazardous Waste: Site Remediation: Residential		Requires the State Water Resources Control Board, working jointly with the Department of Toxic Substances Control and in consultation with the Office of Land Use and Climate Innovation, to develop guidelines for developers and for agencies overseeing development specific site remediations and making determinations of site suitability.	05/04/2026: In SENATE Committee on APPROPRIATIONS: To Suspend File.
CA SB 1260 (Jones (R))	State Environmental Quality Act		Makes nonsubstantive changes to findings and declarations and to the statement of intent of the State Environmental Quality Act.	03/04/2026: To SENATE Committee on RULES.
CA SB 1291 (Gonzalez (D))	Mutual Water Companies		Provides that the Mutual Water Company Open Meeting Act requires a board of directors of a mutual water company that operates a public water system to allow an eligible person to	05/04/2026: In SENATE Committee on APPROPRIATIONS: To Suspend File.

## IRWD 2024 LEGISLATIVE MATRIX

Updated: May 6, 2026

Bill No. Author	Title	IRWD Position	Summary/Effects	Status
			personally attend a meeting of the board, under certain conditions. Authorizes a board of directors of a mutual water company with less than a specified number of connections to use teleconferencing to provide any eligible person access to the meeting.	
<b>CA SB 1313</b> (McNerney (D))	Drinking Water: Perfluoroalkyl and Polyfluoroalkyl		Provides that moneys in the Safe Drinking Water State Revolving Fund and its special accounts may be considered eligible and expended for projects that address perfluoroalkyl and polyfluoroalkyl substances in drinking water. Makes an appropriation.	04/27/2026: In SENATE. Read second time and amended. Re-referred to Committee on APPROPRIATIONS.
<b>CA SB 1318</b> (Allen (D))	Coastal Resources: Local Coastal Program		Requires the State Coastal Commission to approve a coastal development permit or a local coastal program amendment restricting or prohibiting non owner occupied short term rentals, regardless of the availability of other visitor serving accommodations, if the local agency made findings that it was necessary to address significant local housing needs and the commission determines that the permit or amendment strikes a reasonable balance between local housing needs and public access to the coast.	04/27/2026: In SENATE. Read second time and amended. Re-referred to Committee on APPROPRIATIONS.
<b>CA SB 1326</b> (Wahab (D))	Environmental Quality Act: Tribal Resources	Seek Amendments	Modifies the definition of tribal cultural resource to, among other things, include a site, feature, place, cultural landscape, sacred place, or object with cultural value to a California Native American tribe that is identified by the Native American Heritage Commission as a sacred place, as provided, or included in a local tribal register.	05/04/2026: In SENATE Committee on APPROPRIATIONS: To Suspense File.
<b>CA SB 1330</b> (Arreguin (D))	Assault and Battery: Utility Workers		Makes an assault or battery committed against a utility worker, as defined, who is engaged in the performance of their duties punishable by imprisonment in a county jail not exceeding one year, by a fine not exceeding a specified, or by both that fine and imprisonment.	04/20/2026: In SENATE Committee on APPROPRIATIONS: To Suspense File.

## IRWD 2024 LEGISLATIVE MATRIX

Updated: May 6, 2026

Bill No. Author	Title	IRWD Position	Summary/Effects	Status
CA SB 1335 (Strickland (R))	Tenancy: Disposition of Personal Property Abandoned		Provides that existing law provides optional procedures for a landlord to dispose of personal property that remains on the premises, including common areas, after a tenancy has terminated and the premises has been vacated by the tenant. Establishes similar optional disposition of personal property that remains in a common area during a tenancy. Requires the landlord to give written notice to the tenant or any other person the landlord reasonably believes is the owner of the personal property.	04/21/2026: Re-referred to SENATE Committee on JUDICIARY.
CA SB 1346 (McGuire (D))	California Coastal Commission: Powers and Duties		Makes a nonsubstantive change to provisions relative to the California Coastal Commission.	03/04/2026: To SENATE Committee on RULES.
CA SB 1350 (McNerney (D))	Energy: Renewable Electrical Generation Facilities		Expand the definition of renewable electrical generation facility to include a facility that converts hydrogen gas to electricity in a turbine and meets specified criteria, including that the hydrogen used in the turbine is solely derived from a non-fossil-based feedstock or through the electrolysis of water using electricity generated from another renewable electrical generation facility and the manufacturing of the hydrogen does not result in resource shuffling or use unbundled renewable energy credits.	04/28/2026: In SENATE. Read second time and amended. Re-referred to Committee on APPROPRIATIONS.
CA SB 1357 (Ochoa Bogh (R))	Recall Elections: Notice of Intention		Relates to Recall elections. Requires the proponents' signatures and the street numbers and street names of their residence to be redacted or otherwise excluded from the notice of intention before it is made available to the public.	05/04/2026: In SENATE Committee on APPROPRIATIONS: To Suspense File.
CA SB 1361 (Durazo (D))	Transit Oriented Housing Developments		Provides that existing law prohibits a local government from adopting any requirement that applies to a project solely or partially on the basis that the project is seeking approval as a transit-oriented housing development. Prohibits a local government with an existing or planned transit-oriented	04/30/2026: In SENATE. Read second time and amended. To third reading.

## IRWD 2024 LEGISLATIVE MATRIX

Updated: *May 6, 2026*

Bill No. Author	Title	IRWD Position	Summary/Effects	Status
			development stop from taking specified actions with respect to transit providers and transit projects.	
<b>CA SB 1369</b> (Reyes (D))	Recall Petitions		Provides that existing law requires a State or local initiative, referendum, or recall petition that is required to be signed by voters to contain specified notices, including a notice that the petition may be circulated by a paid signature gatherer or volunteer. Requires the paid signature gatherer to orally disclose to each person, before providing the petition for the persons signature, that they are being paid to circulate the petition.	04/13/2026: In SENATE. Read second time. To third reading.
<b>CA SB 1370</b> (Stern (D))	Wildfire Fund: Report		Requires the the Wildfire Fund Administrator to present specified recommendations to specified Senate committees.	04/28/2026: In SENATE. Read second time. To third reading.
<b>CA SB 1383</b> (Arreguin (D))	Housing Development: Density Bonus: Incentives		Provides that existing law requires a city or county to grant incentives or concessions requested by an applicant for a density bonus except under prescribed circumstances. Excludes a reduction in site development standards, a modification of zoning code or architectural design requirements, and other regulatory incentives or concessions that include or relate to a labor standard from the definition of incentives or concessions.	04/30/2026: In SENATE. Read second time. To third reading.
<b>CA SB 1388</b> (Durazo (D))	Local Agencies: Maintenance of Natural Habitat		Authorizes a local agency to contract with a joint powers authority to perform improvement and maintenance of natural habitat.	04/30/2026: In SENATE. Read second time. To Consent Calendar.
<b>CA SB 1389</b> (Dahle M (R))	The Political Reform Act of 1974: Late Filing of Report		Establishes a limit on liability of \$100 for the late filing of an original statement of economic interest. Provides that for any other original statement or report, limits liability for a late filing at an amount equal to the aggregate amount of any contributions, expenditures, and other amounts reported on the statement or report, or \$100, whichever is greater.	05/05/2026: In SENATE. Read second time. To Consent Calendar.

## IRWD 2024 LEGISLATIVE MATRIX

Updated: May 6, 2026

Bill No. Author	Title	IRWD Position	Summary/Effects	Status
CA SB 1404 (Stern (D))	Wildfire Prevention: State Responsibility Areas: Fire		Deletes the repeal date of the above-described provisions, thereby extending the operation of those provisions indefinitely. Reinstates the fire prevention fee ensures dedicated, sustainable funding for fire prevention in state responsibility areas, reducing risk to residents. Provides that funding sustains fire prevention education programs for residents and supports fire-related law enforcement activities.	05/04/2026: In SENATE Committee on APPROPRIATIONS: To Suspend File.
CA SB 1409 (Rubio (D))	Horse Racing: Charity Days		Requires each licensed racing association that conducts a specified number of weeks or less of racing to designate a specified number of racing days, and each licensed racing association that conducts more than a specified number of weeks of racing to designate a specified number of racing days during any one meeting, to be conducted as charity days for the purpose of distributing the net proceeds to beneficiaries.	04/09/2026: In SENATE. Read second time and amended. Re-referred to Committee on RULES.
CA SB 1413 (Richardson (D))	State Vehicle Fleet: Zero-Emission Vehicles		Makes nonsubstantive changes to the State vehicle fleet ensuring that at least a specified percentage of the light-duty vehicles purchased for the state vehicle fleet each fiscal year are zero-emission vehicles, except as provided.	03/04/2026: To SENATE Committee on RULES.
CA SB 1417 (Perez (D))	Mutual Water Companies: Assessments and Water Charges		Prohibits a mutual water company from charging, issuing a bill, or otherwise seeking to hold tenants of shareholders responsible for the costs of water or its delivery, except for specified tenants, and would require all notices of charges for water to be sent to the last known address of the shareholder or tenant.	04/23/2026: In SENATE. Read second time and amended. To third reading.
CA SB 1420 (Richardson (D))	Vote by Mail Ballots and Early Voting		Requires the Secretary of State to promulgate, and post on its internet website, regulations setting forth procedures that a county elections official must follow to implement voter education and outreach initiatives to inform the public about vote by mail and early voting procedures. Requires the Secretary of State to include information about these vote by mail and early voting procedures in the State Voter Information Guide.	04/20/2026: In SENATE Committee on APPROPRIATIONS: To Suspend File.

## IRWD 2024 LEGISLATIVE MATRIX

Updated: May 6, 2026

Bill No. Author	Title	IRWD Position	Summary/Effects	Status
<b>CA SB 1423</b> (Stern (D))	Active Transportation Program: Report		Requires the commission, on or before January 1, 2028, to conduct a study, and submit a report to the Legislature, on opportunities to improve equity, accessibility, cost-effectiveness, and the ease of application for prospective applicants for the Active Transportation Program.	04/23/2026: In SENATE. Read second time and amended. Re-referred to Committee on APPROPRIATIONS.
<b>CA SB 1425</b> (Cortese (D))	High Speed Rail Authority: Property: Right of Way		Establishes a permit program, administered by the High Speed Rail Authority, for encroachments on the authority's rights of way. Makes any person who installs or performs an encroachment within the authority's right of way, without a permit, guilty of a misdemeanor. Provides civil penalties for specified categories of encroachment. Relates to the High Speed Rail Property Fund.	05/04/2026: In SENATE Committee on APPROPRIATIONS: Not heard.
<b>US H 231</b> (Hageman (R))	Energy and Water Development and Related Agencies		Amends the Energy and Water Development and Related Agencies Appropriations Act, to reauthorize the Colorado River System conservation pilot program.	02/12/2025: In HOUSE Committee on NATURAL RESOURCES: Ordered to be reported as amended.
<b>US H 331</b> (Fulcher (R))	Aquifer Recharge Flexibility Clarification Act		Amends the Aquifer Recharge Flexibility Act to clarify a provision relating to conveyances for aquifer recharge purposes.	05/14/2025: To SENATE Committee on ENERGY AND NATURAL RESOURCES.
<b>US H 337</b> (Costa (D))	Groundwater Recharge and Water Supply Support Act		Provides technical and financial assistance for groundwater recharge, aquifer storage, and water source substitution projects.	01/13/2025: To HOUSE Committee on NATURAL RESOURCES.
<b>US H 338</b> (Costa (D))	Enhanced Surface and Groundwater Storage Act	Support	Amends the Infrastructure Investment and Jobs Act to increase surface water and groundwater storage.	11/12/2025: In HOUSE Committee on NATURAL RESOURCES: Referred to Subcmt on WATER, WILDLIFE AND FISHERIES.
<b>US H 471</b> (Westerman (R))	Fix Our Forests Act		Expedites the National Environmental Policy Act of 1969; improves forest management activities on National Forest System lands, on public lands under the jurisdiction of the Bureau of	01/23/2025: In HOUSE. Passed HOUSE. *****To SENATE.

## IRWD 2024 LEGISLATIVE MATRIX

Updated: *May 6, 2026*

Bill No. Author	Title	IRWD Position	Summary/Effects	Status
			Land Management, and on Tribal lands to return resilience to overgrown, fire prone forested lands, and for other purposes.	
<b>US H 1267</b> (Perez (D))	CERCLA Liability Exemption for PFAS Releases	Support	Exempts certain entities from liability under the Comprehensive Environmental Response, Compensation, and Liability Act of 1980 with respect to releases of perfluoroalkyl and polyfluoroalkyl substances.	02/12/2025: To HOUSE Committee on TRANSPORTATION AND INFRASTRUCTURE.
<b>US H 2093</b> (Calvert (R))	Federal Water Pollution Control Act	Support	Amends the Federal Water Pollution Control Act with respect to permitting terms.	03/14/2025: To HOUSE Committee on TRANSPORTATION AND INFRASTRUCTURE.
<b>US H 2269</b> (McClain (R))	Labeling of Products With Do Not Flush Warning	Support	Requires certain products to be labeled with "Do Not Flush" labeling.	06/23/2025: In HOUSE. Passed HOUSE. *****To SENATE.
<b>US H 2344</b> (Schakowsky (D))	Drinking Water and Wastewater Threat Preparedness		Establishes a program to increase drinking water and wastewater system threat preparedness and resilience.	03/25/2025: To HOUSE Committee on ENERGY AND COMMERCE.
<b>US H 2940</b> (LaHood D (R))	Internal Revenue Code		Amends the Internal Revenue Code of 1986 to allow an investment credit for certain water reuse projects.	04/17/2025: To HOUSE Committee on WAYS AND MEANS.
<b>US H 3845</b> (Gray (D))	Endangered Species Act		Amends the Endangered Species Act of 1973 to expand the exemption process under section 7 of that Act with respect to national security and significant adverse national or regional economic impacts.	06/09/2025: To HOUSE Committee on NATURAL RESOURCES.
<b>US H 3898</b> (Collins M (R))	Federal Water Pollution Control Act		Amends the Federal Water Pollution Control Act to make targeted reforms with respect to Waters of the United States and other matters.	12/15/2025: To SENATE Committee on ENVIRONMENT AND PUBLIC WORKS.

## IRWD 2024 LEGISLATIVE MATRIX

Updated: May 6, 2026

Bill No. Author	Title	IRWD Position	Summary/Effects	Status
<b>US H 4168</b> (Fitzpatrick B (R))	National Primary Drinking Water Regulation for PFAS		Codifies a national primary drinking water regulation for PFAS.	06/26/2025: To HOUSE Committee on ENERGY AND COMMERCE.
<b>US H 4733</b> (Sorensen (D))	Low-Income Household Water Assistance Program		Authorizes the Low-Income Household Water Assistance Program.	12/01/2025: In HOUSE Committee on TRANSPORTATION & INFRASTRUCTURE: Referred to Subcommittee on WATER RESOURCES AND ENVIRONMENT.
<b>US H 5414</b> (Van Drew (R))	National Dam Safety Program Act		Amends the National Dam Safety Program Act to reauthorize certain assistance to States.	09/16/2025: To HOUSE Committee on TRANSPORTATION AND INFRASTRUCTURE.
<b>US H 5566</b> (Carbajal (D))	Federal Water Pollution Control Act		Amends the Federal Water Pollution Control Act and the Safe Drinking Water Act to reauthorize certain programs for water infrastructure resilience and sustainability.	12/01/2025: In HOUSE Committee on TRANSPORTATION & INFRASTRUCTURE: Referred to Subcommittee on WATER RESOURCES AND ENVIRONMENT.
<b>US HJR 18</b> (Palmer (R))	National Primary Drinking Water Regulations		Provides for congressional disapproval under a specified chapter and title, United States Code, of the rule submitted by the Environmental Protection Agency relating to "National Primary Drinking Water Regulations for Lead and Copper: Improvements (LCRI)".	01/13/2025: To HOUSE Committee on ENERGY AND COMMERCE.
<b>US S 322</b> (Padilla (D))	Forecasts of Atmospheric Rivers		Improves the lead time, accuracy, and dissemination of forecasts of atmospheric rivers throughout the United States.	01/29/2025: To SENATE Committee on COMMERCE, SCIENCE, AND TRANSPORTATION.
<b>US S 1092</b> (Merkley (D))	Labeling of Products With Do Not Flush Warning	Support	Requires certain products to be labeled with Do Not Flush labeling.	03/22/2026: In SENATE. Passed SENATE. *****To HOUSE.

## IRWD 2024 LEGISLATIVE MATRIX

Updated: May 6, 2026

Bill No. Author	Title	IRWD Position	Summary/Effects	Status
<b>US S 1118</b> (Markey (D))	Drinking Water and Wastewater Threat Preparedness		Establishes a program to increase drinking water and wastewater system threat preparedness and resilience.	03/25/2025: To SENATE Committee on ENVIRONMENT AND PUBLIC WORKS.
<b>US S 1549</b> (Gallego (D))	Safe Drinking Water Act		Amends the Safe Drinking Water Act to provide grants under the Drinking Water Infrastructure Risk and Resilience Program for training programs relating to protecting public water systems from and responding to cyberattacks.	05/01/2025: To SENATE Committee on ENVIRONMENT AND PUBLIC WORKS.
<b>US S 2388</b> (Gallego (D))	Federal Water Pollution Control Act		Amends the Federal Water Pollution Control Act to reauthorize the pilot program for alternative water source projects.	07/23/2025: To SENATE Committee on ENVIRONMENT AND PUBLIC WORKS.
<b>US S 3609</b> (Padilla (D))	Community Protection and Wildfire Resilience Grants		Establishes a community protection and wildfire resilience grant program.	01/08/2026: To SENATE Committee on HOMELAND SECURITY AND GOVERNMENTAL AFFAIRS.
<b>US S 3737</b> (Padilla (D))	Reclamation States Emergency Drought Relief Act		Amends the Reclamation States Emergency Drought Relief Act of 1991 to provide financial and technical assistance to eligible entities for the conduct of innovative approaches to voluntary water partnership agreements among multiple water users and projects conducted by individual agricultural entities.	03/17/2026: Subcommittee on WATER AND POWER hearings held.
<b>US S 3738</b> (Padilla (D))	Infrastructure Investment and Jobs Act		Amends the Infrastructure Investment and Jobs Act to reauthorize the large-scale water recycling and reuse program, to establish a Water Conveyance Improvement Program.	03/17/2026: Subcommittee on WATER AND POWER hearings held.

Note: This page is intentionally left blank.

May 26, 2026

Prepared by: K. Swan

Submitted by: C. Compton

Approved by: Paul A. Cook 

## CONSENT CALENDAR

### REGISTRAR OF VOTERS INFORMATION REQUEST AND CANDIDATE STATEMENT WORD LIMIT FOR THE ELECTION OF THE BOARD OF DIRECTORS

#### SUMMARY:

Members of the IRWD Board of Directors are elected on a staggered basis to four-year terms every two years during the general elections held in even-numbered years. Prior to each general election at which a member of the Board is to be elected, the Office of the Registrar of Voters requests that the District submit a “Transmittal of Election Information” form. Staff recommends the Board authorize the District Secretary to file the “Transmittal of Election Information” form for each general election providing the Registrar of Voters with the requested information, selecting a 200-word limit for Candidate Statements of Qualifications, and indicating that the District will not pay for the Statements of Qualifications.

#### BACKGROUND:

IRWD transitioned to a division-based election of its Board of Directors in November 2020. The members of the Board will continue to be elected on a staggered basis to four-year terms every two years during the general elections held in even-numbered years. The Board members from Divisions 1 and 4 were elected in 2024, and the Board members from Divisions 2, 3, and 5 will be elected in 2026.

#### Registrar of Voters “Transmittal of Election Information” Form:

Prior to each general election at which a member of the Board is to be elected, the Office of the Registrar of Voters requests that the District submit a “Transmittal of Election Information” form. Provided as Exhibit “A” is a letter from the Office of the Registrar of Voters regarding the “Transmittal of Election Information” for the November 2026 general election. The “Transmittal of Election Information” form requests that the District:

- Confirm the District’s boundaries and the boundaries of the District’s divisions;
- Provide the Registrar of Voters with the number of directors to be elected in that election, and the divisions from which they are to be elected;
- Provide the Registrar of Voters with a list of incumbents; and
- Select either a 200- or 400-word limit for Candidate Statements of Qualifications and indicate whether the District will or will not pay for those statements.

For many years, the District has submitted this form and provided the requested boundary, election, and incumbent information. Historically, the District has authorized 200 words and has elected not to pay for candidate statements.

Staff recommends that the Board authorize the District Secretary to file the “Transmittal of Election Information” form for each general election confirming the District political and division boundaries, providing the Registrar of Voters with the requested information, selecting a 200-word limit for Candidate Statements of Qualifications, and indicating that the District will not pay for the Statements of Qualifications.

FISCAL IMPACTS:

Not applicable.

ENVIRONMENTAL COMPLIANCE:

Not applicable.

COMMITTEE STATUS:

This item was not reviewed by a Committee.

RECOMMENDATION:

THAT THE BOARD AUTHORIZE THE DISTRICT SECRETARY TO FILE THE “TRANSMITTAL OF ELECTION INFORMATION” FORM FOR EACH GENERAL ELECTION CONFIRMING IRWD’S POLITICAL AND DIVISION BOUNDARIES, PROVIDING THE REGISTRAR OF VOTERS WITH THE REQUESTED INFORMATION, SELECTING A 200-WORD LIMIT FOR CANDIDATE STATEMENTS OF QUALIFICATIONS, AND INDICATING THAT IRWD WILL NOT PAY FOR THE STATEMENTS OF QUALIFICATIONS.

LIST OF EXHIBITS:

Exhibit “A” – Email from the Office of the Registrar of Voters regarding the “Transmittal of Election Information”

Exhibit "A"

---

**From:** Registrar of Voters, County of Orange, CA <julianna.mailhot@ocvote.gov>  
**Sent:** Thursday, May 14, 2026 11:49 AM  
**Subject:** [EXTERNAL] November 3, 2026 General Election Transmittal and Map Request

**Caution: This email originated from outside IRWD. Do not click links or open attachments unless you know**

Good afternoon General Manager/Director,

In preparation for the upcoming General Election, the Registrar of Voters would like information regarding current Incumbents and the District offices that will be included in this election.

The Registrar of Voters asks that you submit your Transmittal of Election Information form and District Map through our online Election Jurisdiction Verification portal. The portal will allow you to complete, sign and upload your district information, in one convenient place.

On the Transmittal of Election Information page, please list the names of Directors whose terms expire and whose seats will be scheduled for election on November 3, 2026. This would include any Directors appointed since your last election. Appointed Directors must file for the two-year unexpired term if they were appointed to fill a vacancy which would not have been scheduled for election until 2028.

We also need to know if your District is authorizing 200 or 400 words to be used in a Candidate's Statement of Qualifications. Additionally, please advise if your District will be paying for the candidate's statement on behalf of the candidate.

Please upload the completed Transmittal of Election Information form by May 29, 2026.

On the District Map page, you will print, sign, and upload you district map and verification form.

Pursuant to Elections Code §10522, the district is required to submit a map showing the current district boundary lines, with divisions (if any), regardless if changes have occurred, by July 1, 2026. We request you submit the map verification by June 22, 2026 to give us sufficient time to update precincts if your District modified its map.

To get started, please click on the invitation link:

<https://ocvote.gov/apps/ejv/register/?invitationCode=eyJmdWxsLW5hbWUiOiJQYXVsIEEuIENvb2siLCJyZWdpc3Rl>

Note: The above invitation link is unique, and you should not forward it to anyone else. If you would like others to complete the documents on your behalf, please email their individual name and email address to Julianna.Mailhot@ocvote.gov, and a new invitation link will be sent.

Candidate Filing for the November 3, 2026 General Election will be July 13, 2026 through August 7, 2026, 5:00 p.m. The Candidate's Handbook will be on our website before the filing period begins. We ask that you post this information to advise your members of these important dates.

Thank You.

Julianna Mailhot | Candidate and Voter Services Manager  
Orange County Registrar of Voters  
1300 S. Grand Avenue, Bldg C | Santa Ana, California 92705 | 714.567.7563  
julianna.mailhot@ocvote.gov

Note: This page is intentionally left blank.

May 26, 2026

Prepared by: M. Seesangrit / A. McNulty

Submitted by: F. Nye / P. Weghorst

Approved by: Paul A. Cook 

## CONSENT CALENDAR

### WATER EFFICIENCY TACTICAL INCENTIVE FUNDING AUTHORIZATION

#### SUMMARY:

IRWD's Water Use Efficiency Program includes tactical incentives to encourage customers to remove turf and to install commercial and outdoor water conservation devices that are cost-effective to IRWD, as well as the customer. Municipal Water District of Orange County (MWDOC) administers incentives for regional programs on behalf of IRWD via a multi-year Water Conservation Participation Agreement. Staff recommends that the Board authorize the General Manager to allocate \$877,000 from over-allocation revenues to co-fund the regional incentive programs for Fiscal Year (FY) 2026-27.

#### BACKGROUND:

Tactical incentives are a key element of IRWD's Water Use Efficiency Program. The financial incentives provided by IRWD supplement regional programs administered by MWDOC. IRWD incentives are provided after considering avoided costs to IRWD, available regional funding, device costs, and their effectiveness as a tool to drive change. Tactical incentive programs focus on outdoor water use efficiency through the highly visible and influential turf removal rebate program and the installation of various other water conservation devices.

In June 2025, the Board approved the execution of the second amendment to the multi-year Water Conservation Participation Agreement with MWDOC to administer IRWD's incentives for regional rebate programs. That agreement and second amendment are provided as Exhibits "A" and "B", respectively. Each fiscal year, the agreement is amended to allocate funding and to specify device rebate funding levels for outdoor Residential, Commercial, Water Savings Incentive, Spray to Drip Conversion, and Turf Removal programs. This year, enhanced funding from IRWD will be added to two commercial devices to support the Commercial, Industrial, and Institutional (CII) performance measures and Best Management Practices that urban water suppliers must implement to comply with the "Making Conservation a California Way of Life" regulation. Enhanced funding for these two commercial devices are described below.

#### Food Defrosting Equipment Rebate:

The commercial food defroster is a specialized thawing device that significantly reduces water use by recirculating chilled water within the sink rather than relying on continuous flow. The deemed savings for each device is 0.83 acre-feet (AF) per year, with a five-year lifetime savings of 4.15 AF, as compared with the traditional running-water method commonly used in restaurant kitchens. Each device costs approximately \$3,500, with a current regional incentive of \$800 per eligible model. Staff proposes an additional IRWD supplemental incentive of \$700 for a total of \$1,500 per unit to enhance affordability and speed adoption. IRWD's estimated avoided cost for the life of each unit is \$9,860.

Commercial Smart Timer Rebate:

To support the goals of the District's Commercial Landscape Irrigation Improvement Program in enhancing irrigation system efficiency, staff proposes adding supplemental funding to the regional commercial smart timer incentive. The deemed savings per station for commercial controllers is 0.018 acre feet (AF) per year, with a ten-year lifetime savings of 0.18 AF. Staff recommends providing IRWD supplemental funding in the amount of \$15 per active station, which would be added to the standard incentive of \$35 per active station. The lifetime avoided cost per station is \$225 for CII potable landscape customers and \$162 for CII recycled landscape customers.

To continue providing program incentives through June 2027, staff recommends that the Board authorize the General Manager to allocate \$877,000 in funding to the FY 2026-27 incentive programs administered through IRWD's participation agreement with MWDOC and to execute addenda to the agreement as necessary. The proposed allocation of IRWD tactical incentive funding and the specific funding levels for FY 2026-27 are shown in Exhibit "C". The allocations are based on prior customer participation rates and anticipated regional funding.

FISCAL IMPACTS:

Funding from the overallocation revenues for tactical incentives in the amount of \$877,000 is included in IRWD's FY 2026-27 Operating Budget.

ENVIRONMENTAL COMPLIANCE:

Not applicable.

COMMITTEE STATUS:

This item was reviewed at the Water Resources Policy and Communications Committee on May 13, 2026.

RECOMMENDATION:

THAT THE BOARD AUTHORIZE THE GENERAL MANAGER TO ALLOCATE \$877,000 IN FUNDING TO THE FISCAL YEAR 2026-27 TACTICAL INCENTIVE PROGRAMS ADMINISTERED THROUGH THE WATER CONSERVATION PARTICIPATION AGREEMENT BETWEEN MUNICIPAL WATER DISTRICT OF ORANGE COUNTY AND IRVINE RANCH WATER DISTRICT; AND TO EXECUTE ADDENDA TO THE AGREEMENT, AS MAY BE NECESSARY, TO ALLOCATE FUNDS TO SPECIFIC PROGRAMS AND MODIFY DEVICE INCENTIVE LEVELS BASED ON CUSTOMER PARTICIPATION RATES AND REGIONAL PROGRAM FUNDING LEVELS.

LIST OF EXHIBITS:

Exhibit "A" – Water Conservation Participation Agreement with MWDOC

Exhibit "B" – Second Amendment to the MWDOC Agreement

Exhibit "C" – Tactical Incentive Program Funding Allocations for FY 2026-27

**Water Conservation Participation Agreement between  
the Municipal Water District of Orange County and Irvine Ranch Water District**

This Water Conservation Participation Agreement (“Agreement”) is made between the Municipal Water District of Orange County (“MWDOC”) and Irvine Ranch Water District (“Participant Agency”). MWDOC and Participant Agency may be collectively referred to as “Parties” and individually as “Party.”

Recitals

- A The Metropolitan Water District of Southern California (“Metropolitan”) provides incentive funding to residential, commercial, and industrial water users in its service area for a variety of water conservation activities, including, but not limited to, rebates for the purchase and installation of water-saving devices (“Metropolitan Base Incentives”).
- B MWDOC is a member agency of Metropolitan and has agreements with Metropolitan that enable residential, commercial, and industrial water users in MWDOC’s service area, and for the benefit of MWDOC’s member agencies, to participate in and take advantage of Metropolitan’s Base Incentives.
- C Participant Agency, as a MWDOC member agency or a direct Metropolitan member agency, may elect to participate in Metropolitan’s program to replace non-conserving items within its service area.
- D The Metropolitan Base Incentives amounts for each eligible device or program available to MWDOC and Metropolitan member agencies are listed in the attached Addendums 1A and 1B. It is expected that Metropolitan will establish funding for additional water conservation items and to change some or all of the existing funding rates throughout the term of this Agreement. Any such changes will be incorporated herein by amendment to Addendums 1A and 1B.
- E Metropolitan and MWDOC each have fiscal responsibility to manage their individual budgets, and hence may have a need to limit availability of funds.
- F MWDOC and Metropolitan member agencies may also choose to provide additional supplemental funding of their own to augment the Metropolitan Base Incentives. Based on the terms and conditions of this Agreement, MWDOC will facilitate supplemental funding for Participant Agency through the Metropolitan rebate contractor (“Rebate Contractor”) or MWDOC directly. Metropolitan member agencies will coordinate any supplemental funding directly with Metropolitan.
- G In addition to the Metropolitan Base Incentives, MWDOC has developed and arranged additional local, state, and federal grant funding (“Grant Funding”) for eligible devices in a number of water conservation programs (“MWDOC Administered Programs”) that MWDOC offers to Participant Agency and Metropolitan member agencies. This grant funding may be used to enhance the Metropolitan Base Incentives. Granting agencies

include, but are not limited to, the Department of Water Resources and the United States Bureau of Reclamation.

- H. Participant Agency may also operate customized, local water conservation incentive programs in their respective service areas (“Participant Agency Administered Programs”) and may have access to the Metropolitan Base Incentives and Grant Funding for such, subject to MWDOC and Metropolitan approval and the terms and conditions of this Agreement and any MWDOC and/or Metropolitan agreements.
- I. The purpose of this Agreement is to create a master water conservation participation agreement between MWDOC and Participant Agency that combines all of the conservation programs and incentives (“Programs”) into one agreement. Addendums to this Agreement will be issued for changes involving Metropolitan approved items, MWDOC Board approved items, Grant Funding, adding and subtracting MWDOC Administered Programs and Participant Agency Administered Programs as identified in Section 2, and changes to incentive programs, including funding and incentive levels.

NOW THEREFORE, in consideration of the promises and covenants hereinafter set forth, the Parties do agree as follows:

#### Section 1: Agreement Term and Administration

- 1.1 This Agreement will be effective on July 1, 2015 or upon execution of this Agreement by all Parties, whichever is later, and shall terminate on June 30, 2025 (“Term”). Continuance of this Agreement will be subject to annual budget approval by MWDOC’s Board of Directors.
- 1.2 This Agreement may be amended at any time by written mutual agreement of the Parties, or by Addendums issued by MWDOC as set forth in Recital I.
- 1.3 This Agreement may be terminated by either Party for any reason upon thirty (30) days written notice to the other Party.
- 1.4 All Addendums are enforced for the duration of this Agreement unless the Addendums are amended or terminated by either Party.
- 1.5 In the event the Agreement is terminated early, Participant Agency is responsible for payment of any funding contributions required by this Agreement that that were initiated prior to the effective date of the termination. For purposes of this Agreement, an application is deemed initiated when an application has been received by Metropolitan’s rebate vendor, EGIA, by MWDOC, or a reservation has been made within any of MWDOC’s online application portals that is pursuant to any of the programs described within this Agreement and the attached Addendums.
- 1.6 Notwithstanding any other provision in this Agreement, funds for all of the programs described within this Agreement and the attached Addendums are conditioned upon the

availability of funds and MWDOC is under no obligation to provide funding for any of the programs if MWDOC determines, in its own discretion, that such funding is exhausted, reduced, eliminated, or unavailable from any funding source, for any reason.

## Section 2: Program Funding

### **2.1 Supplemental Funding**

2.1.1 In addition to the Metropolitan Base Incentives, Participant Agency may provide additional funding to augment the Metropolitan Base Incentives amounts for those programs and devices that Participant Agency identifies, and in the amounts indicated, in the appropriate locations in Addendums 2A, 2B, and 2C (“Supplemental Funding”). The Supplemental Funding listed in Addendums 2A through 2C shall specify the amount of Supplemental Funding Participant Agency will provide per device or program, as well as the total maximum Supplemental Funding amount committed to each category of device or program. If the Participant Agency does not complete, sign, and return Addendums 2A through 2C to MWDOC, notwithstanding any other provision of this Agreement, the Participant Agency will not be bound by this Section or the provisions in Addendums 2A through 2C. In general, Supplemental Funding Addendums submitted by the 15<sup>th</sup> of a month will become effective the first of the following month.

2.1.2 If Participant Agency elects to provide Supplemental Funding or enhanced incentives under this Agreement for any device or program, Participant Agency is responsible for tracking the use of and the remaining availability of those funds. MWDOC will assist, in every way possible, but the ultimate responsibility for tracking all Participant Agency funding is the responsibility of Participant Agency. Participant Agency will ultimately be responsible for any overuse of Participant Agency Supplemental Funding.

2.1.3 Any requests for changes or revisions to Participant Agency’s Supplemental Funding, including funding transfers between Programs, must be submitted by Participant Agency to MWDOC in the form of revised Addendum 2s listing the new funding amounts/limits.

2.1.4 The Participant Agency may elect to participate in the Supplemental Funding Program and be bound by the provisions of this Section 2.1, Sections 3, 5, 6, 7, and 8 of this Agreement, and Addendum 2A through 2C by having its authorized representative complete and sign Addendum 2A through 2C in the spaces provided.

### **2.2 MWDOC Administered Programs**

2.2.2 Participant Agency may elect to take advantage of the MWDOC Administered Programs by having its authorized representative complete and sign Addendums 3A through 3C in the spaces provided. If Participant Agency completes and signs Addendums 3A through 3C, Participant Agency agrees to be bound by the provisions of this Section 2.2, Sections 3, 5, 6, 7, and 8 of this Agreement, and Addendums 3A through

3C. If the Participant Agency does not complete, sign, and return Addendums 3A through 3C, notwithstanding any other provision of this Agreement, the Participant Agency will not be bound by this Section or the provisions in Addendums 3A through 3C.

## **2.3 Participant Agency Administered Programs**

2.3.1 From time to time, funding may be made available for Participant Agency to operate a customized member agency administered local water conservation incentive program or programs (“Participant Agency Administered” “PA” or “MAA Program”) in its service area and access the Metropolitan Base Incentives for such, subject to MWDOC approval of the program and the terms and conditions of this Agreement and Addendum 4. The Participant Agency Administered Program(s) and requirements in connection with it are described in more detail in Addendum 4.

2.3.2 Upon receipt of approval of a Participant Agency Administered Program by MWDOC, Participant Agency is bound by the provisions of Sections 3, 5, 6, 7, and 8 of this Agreement and Addendum 4.

## **2.4 Exhaustion of Funding**

2.4.1 In the event Participant Agency provided funding for any Program or device is exhausted, and Participant Agency does not elect to add additional funding or transfer available funding from another Program or device, MWDOC will discontinue offering the additional rebate funding for that Program or device in Participant Agency’s service area. Notwithstanding any other provision in this Agreement, MWDOC may terminate this Agreement as it relates to Section 2 at any time without prior notice in the event that MWDOC determines that funding for any device or program on Addendums 2 through 4 or MWDOC Grant Funding is exhausted, reduced, eliminated, or unavailable from any funding source, for any reason.

## **Section 3: Participant Agency Responsibility and Ownership**

3.1 Participant Agency, at its sole discretion, may independently contract with its own agents under separate agreements for program administration and management for any Participant Agency Administered Program provided that doing so does not compromise program performance, create or present a conflict of interest, or violate the terms of this Agreement.

3.2 Participant Agency and/or its agent shall provide all necessary services and materials for such Participant Agency Administered Programs including, but not limited to the following: program administration, promotion, marketing materials, data collection, and analysis, installation verification, and reporting.

3.3 All materials and supplies necessary to implement a Participant Agency Administered Program shall be the exclusive property of Participant Agency. MWDOC shall have no

ownership, right, title, security interest, or other interest in any Participant Agency Administered Program materials or supplies, nor any rights duties, or responsibilities, therefor.

- 3.4 Participant Agency is responsible for assuring that any Participant Agency Administered Program complies with all federal, state, and local requirements.
- 3.5 Participant Agency agrees to cooperate with MWDOC's data management activities related to assessing device saturation and program success.
- 3.6 As part of any Participant Agency Administered Program, Participant Agency shall use, maintain, and submit to MWDOC within the designated timeframe an electronic database, to be approved by MWDOC prior to use, for any conservation items installed, distributed, or rebated by Participant Agency or its agents to avoid duplicate distributions and to determine the saturation rate of items by the appropriate geographic delineation.
- 3.7 Participant Agency is solely responsible for the performance of its staff or representatives in complying with the terms of this Agreement and for the proper allocation and appropriate use of funds provided by Metropolitan and/or MWDOC for the purpose of achieving water conservation savings under this Agreement.

#### Section 4: MWDOC's Obligations

- 4.1 MWDOC will be response to Participant Agency for ensuring that timely reports on the Programs' results are prepared by MWDOC's staff.
- 4.2 MWDOC will develop a database of information regarding participation in the Programs and provide monthly electronic and/or written reports of activity to Participant Agency.
- 4.3 MWDOC will invoice Participant Agency for any Participant Agency funding obligations on a monthly basis for rebates issued in the previous month.
- 4.4 MWDOC does not guarantee any minimum number of rebates will be available for Participant Agency's service area.

#### Section 5 Marketing.

- 5.1 Participant Agency agrees to assist in the marketing of programs it participates in under this Agreement. With regard to Participant Agency Administered Programs, Participant Agency will be solely responsible for marketing its Participant Agency Administered Program to customers in its service area.

#### Section 6: Installation Verification

- 6.1 Participant Agency shall be responsible for conducting installation verifications of items installed, distributed, and/or rebated by Participant Agency under Participant Agency

Administered Programs, and/or for paying all costs associated with this verification. Installation verification measures for program devices must be designed to ensure that materials, installation verifications of eligible program devices, and services meet requirements established by Metropolitan, which requirements will be provided to Participant Agency by MWDOC.

- 6.2 Participant Agency may be responsible for conducting installation verifications of items installed, distributed, and/or rebated by Participant Agency or MWDOC under MWDOC Administered Programs, and/or for paying all costs associated with this verification. Installation verification measures for program devices must be designed to ensure that materials, installation verifications of eligible program devices, and services meet requirements established by Metropolitan, which requirements will be provided to Participant Agency by MWDOC.
- 6.3 MWDOC reserves the right to conduct installation verification of items within Participant Agency's service area.
- 6.4 Participant Agency acknowledges that any device receiving funding from Metropolitan may be subject to an installation verification to be performed by Metropolitan, or its agent(s), at Metropolitan's discretion.
- 6.5 Participant Agency shall promptly refund to MWDOC any amounts paid under any Participant Agency Administered Program or MWDOC Administered Program for installed or distributed devices in the event MWDOC or Metropolitan establishes via installation verification that the program devices were not installed.

#### Section 7: Reporting and Invoicing

- 7.1 For any and all Supplemental Funding provided by Participant Agency and/or Participant Agency provided funding or inspection costs under the MWDOC Administered Programs pursuant to Section 2 of this Agreement, and as more particularly described in Addendums 2 and 3, MWDOC will invoice Participant Agency on a monthly basis for the cost of such funding, and Participant Agency must pay the full amount of such invoice within thirty (30) days of receipt of any such invoice.
- 7.2 For any and all Participant Agency Administered Program(s), Participant Agency will invoice MWDOC on a monthly basis, by the 10<sup>th</sup> of each month, for any approved funding and costs associated with the Participant Agency Administered Program(s) as indicated in and subject to the provisions of Addendum 4. MWDOC is under no responsibility to reimburse Participant Agency for any costs incurred by Participant Agency that are not approved by MWDOC consistent with the terms and conditions of this Agreement and Addendum 4. The invoice package shall include a fully completed, to the satisfaction of MWDOC, Excel customer/applicant spreadsheet showing program activity, and an invoice, signed by the General Manager or designee of Participant Agency, certifying the information provided as accurate. Participant Agency shall use the Excel customer/applicant spreadsheet and Invoice forms approved by MWDOC.

- 7.3 Participant Agency shall maintain all Participant Agency Administered Program information, including Participant Agency applications, water bills, and purchase receipts, for a period of seven years from the end date of this Agreement.
- 7.4 Payment of Participant Agency invoices shall be in the form of either a credit on MWDOC's water bill to Participant Agency or a check made payable to Participant Agency. Method of payment shall be at MWDOC's discretion.

#### Section 8: Confidentiality

- 8.1 MWDOC agrees to maintain the confidentiality of Participant Agency's customer names, addresses, and other information gathered in connection with this Agreement. MWDOC will not cause or permit the disclosure of such information except as necessary to carry out any of the MWDOC Administered or Participant Agency Administered Programs, or as required by law. To the extent that MWDOC contracts with third party contractors to carry out all or any portion of any of the Programs, MWDOC will require such contractors to maintain the confidentiality of such customer information.
- 8.2 Notwithstanding anything to the contrary in this Agreement, Participant Agency acknowledges and agrees that MWDOC may request and use historical water consumption data for purposes of satisfying any grant water use and water quality evaluation requirements of any of the Programs. Participant Agency also acknowledges and agrees that MWDOC may also request to use Program applicant information, such as name, mailing address, site photos, and email address to market other water use efficiency programs to past applicants. A similar provision will be required of every individual applicant.

#### Section 9. Indemnification.

- 9.1 The parties agree that each Party shall be responsible for its own actions, and the actions of its officers, employees, and agents, in performing services under this Agreement. Except as provided in this Agreement and its Addendums, each Party agrees to indemnify and hold the other Party and its officers and agents harmless and agrees to defend the other Party against any claim or asserted liability arising out of its actions, either willful or negligent, or the actions of its officers, employees, and agents, in performing services pursuant to this Agreement. Such indemnity will include any losses relating to any claim made, whether or not a court action is filed, and will include attorney fees and administrative and overhead costs related to or arising out of such claim or asserted liability.
- 9.2 Participant Agency shall include the following language in its agreement with any consultant or contractor retained by Participant Agency to work on any of the Program" "(Consultant) agrees at is sole cost and expense to protect, indemnify, defend, and hold harmless Metropolitan, MWDOC, and their associated Boards of Directors, officers, representatives, agents and employees from and against any and all claims and liability

of any kind (including, but not limited to, any claims or liability for injury or death to any person, damage to property, natural resources or to the environment, or water quality problems) that arise out of or related to Participant Agency's approval, construction, operation, repair, or ownership of any Program. Such indemnity shall include all damages and losses related to any claim made, whether or not a court action is filed, and shall include attorneys' fees, administrative and overhead costs, engineering and consulting fees, and all other costs related to our arising out of such claim or asserted liability."

Section 10. Certification re Lobbying (43 CFR 18)

10.1 The undersigned hereby certifies on behalf of Participant Agency that no Federal appropriated funds have been paid or will be paid, by or on behalf of the Participant Agency, to any person for influencing or attempting to influence an officer or employee of a Member of Congress in connection with the awarding of any Federal contract, the making of any Federal grant, the making of any Federal loan, the entering into of any cooperative agreement, and the extension, continuation, renewal, amendment, or modification of any Federal contract, grant, loan, or cooperative agreement. If any funds other than Federal appropriated funds have been paid or will be paid to any person for influencing or attempting to influence an officer or employee of any agency, a Member of Congress in connection with a Federal contract, grant, loan, or cooperative agreement, the undersigned shall complete and submit Standard Form LLL, "Disclosure Form to Report Lobbying" in accordance with its instructions. To the extent federal funds are involved, the Participant Agency shall require that the language of this certification be included in the awards documents for any sub-awards by the Participant Agency at all tiers (including sub-contracts, sub-grants, and contracts under grants, loans and cooperative agreements) and that sub-recipients, if any, shall certify accordingly.

Section 11. Other Terms

- 11.1 Any alteration or variation of the terms of this Agreement will not be valid unless made in writing and signed by both Parties.
- 11.2 This Agreement will inure to the benefit of and be binding upon the Parties and their respective successors.
- 11.3 The partial or total invalidity of one or more parts of this Agreement will not affect the intent or validity of this Agreement.
- 11.4 This agreement shall be deemed a contract made under the laws of the State of California, and for all purposes will be interpreted in accordance with such laws. The Parties hereby agree and consent to the exclusive jurisdiction of the courts of the State of California, and that the venue of any action brought hereunder will be in Orange County, California.

///  
///

11.5 This Agreement constitutes the entire agreement between the Parties.

IN WITNESS WHEREOF, the parties hereto have executed this Agreement.

MUNICIPAL WATER DISTRICT  
OF ORANGE COUNTY

IRVINE RANCH WATER DISTRICT

By:   
Robert J. Hunter  
General Manager  
Date: 7-14-15

By:   
Paul Cook  
General Manager  
Date: 7-9-15

**Approved as to Form:**  
Bowie, Arneson, Wiles & Giannone

  
Joan C. Arneson  
Legal Counsel  
Date: 6/25/15

Note: This page is intentionally left blank.

**SECOND AMENDMENT  
TO  
WATER CONSERVATION PARTICIPATION AGREEMENT**

This Second Amendment to the Water Conservation Participation Agreement ("Second Amendment") is effective on July 1, 2025 ("Effective Date"), by and between the Municipal Water District of Orange County ("MWDOC") and Irvine Ranch Water District ("Participant Agency"). MWDOC and Participant Agency may be collectively referred to as "Parties" and individually as "Party."

**RECITALS**

- A. The Parties entered into a Water Conservation Participation Agreement dated July 1, 2015, regarding the Participant Agency's participation in certain water conservation programs ("Agreement"). The Agreement was amended by the First Amendment to the Agreement ("First Amendment").
- B. The Parties now intend to amend the Agreement with this Second Amendment to extend the term of the Agreement from June 30, 2025 to June 30, 2035.
- C. The Parties also intend to update the agreement administration and the retention policy, and to clarify the inclusion of all incentive programs as provided in the Agreement as amended.

NOW, THEREFORE, the Parties agree as follows:

**AMENDED TERMS OF AGREEMENT**

- 1. The following Sections of the Agreement are hereby amended and shall now read as follows:
  - a. "1.1 This Agreement will be effective on July 1, 2015, and shall terminate on June 30, 2035 ("Term"). Continuance of this Agreement will be subject to annual budget approval by MWDOC's Board of Directors."
  - b. "1.4 This Agreement encompasses multiple conservation programs that provide incentives to consumers. Addenda to this Agreement will be issued for changes involving Metropolitan and/or MWDOC Board-approved items, grant funding, and changes to incentive programs, including funding and incentive levels. All Addenda are enforced for the duration of this Agreement unless the Addenda are amended or terminated by either Party."
  - c. "2.2.1 Participant Agency may elect to take advantage of the MWDOC Administered Programs by having its authorized representative complete and sign

Addenda 3A through 3E in the spaces provided. If Participant Agency completes and signs Addenda 3A through 3E, Participant Agency agrees to be bound by the provisions of this Section 2.2, Sections 3, 5, 6, 7, and 8 of this Agreement, and Addenda 3A through 3E. If the Participant Agency does not complete, sign, and return Addenda 3A through 3E, notwithstanding any other provision of this Agreement, the Participant Agency will not be bound by Section 2.2 or the provisions in Addenda 3A through 3E.”

- d. “7.3 Participant Agency shall maintain all Participant Agency Administered Program information, including Participant Agency applications, water bills, and purchase receipts, for a period beginning on the date the incentive is first awarded for a given application and respective project and ending seven years later.”
- 2. The word “Addendums” is hereby replaced by the word “Addenda” throughout the entire Agreement.
- 3. Authority to enter into Second Amendment. Each Party represents that the person executing this Second Amendment has the requisite power and authority to execute the Second Amendment and to bind each respective Party.
- 4. Continuing Effect of Agreement. Except as amended by this Second Amendment, all other provisions of the Agreement remain in full force and effect. From and after the date of this Second Amendment, whenever the term “Agreement” appears in the Agreement, it shall mean the Agreement as amended by the First and Second Amendments.
- 5. Execution in Counterparts. This Second Amendment may be executed in duplicate counterparts, each of which shall be deemed an original.

MWDOC and Participant Agency have each caused this Second Amendment to be executed by its duly authorized representative as of the date set forth below the authorized signature.

IN WITNESS WHEREOF, the Parties hereto have executed this Second Amendment.

MUNICIPAL WATER DISTRICT  
OF ORANGE COUNTY

By: Harvey De La Torre  
880E56258E38412  
Harvey De La Torre  
General Manager

Date: 5/22/2025 | 4:37 PM PDT

Approved as to Form:

Signed by:  
By: Joseph Byrne  
500D7833C7264EC  
Joseph Byrne  
General Counsel

Date: 5/22/2025 | 4:27 PM PDT

**PARTICIPANT AGENCY**

Agency Name: \_\_\_\_\_

Irvine Ranch Water District

By:   
Name: Paul A. Cook

Title: General Manager

Date: 22 April 2025

**Approved as to Form:**

By:   
Name: Claire H. Collins

Title: General Counsel

Date: April 22, 2025



Exhibit "C"

Tactical Incentive Program Funding Allocations for FY 2026-27

<b>Program</b>	<b>Maximum Funding</b>	<b>Devices</b>	<b>IRWD Supplemental Funding Level per Device</b>
SoCal Water\$mart Residential Program	\$12,000	Residential Smart Timer	Up to \$120
		Rotating Nozzle	\$2 per nozzle
SoCal Water\$mart Commercial Program	\$15,000	Connectionless Food Steamer	\$485 per compartment
		Food Defrosting Equipment	\$700
		Commercial Ice Making Machine (Tier III)	\$250
		Cooling Tower Conductivity Controller	\$700
		Cooling Tower pH Controller	\$400
		Commercial Smart Timer	\$15 per active station
		Rotating Nozzle	\$2 per nozzle
Water Savings Incentive Program	\$50,000	Performance Based	\$3 per 1,000 gallons/one year
Turf Removal Program	\$720,000	Turf Removal	Not to exceed \$5/SF
Spray to Drip Program	\$80,000	Drip Irrigation	Not to exceed \$1/SF
<b>Total Funding for all Incentive Programs</b>	<b>\$877,000</b>		

Note: This page is intentionally left blank.

May 26, 2026

Prepared by: A. Murphy / B. Waite

Submitted by: K. Burton

Approved by: Paul A. Cook 

## CONSENT CALENDAR

### MICHELSON WATER RECYCLING PLANT SOLIDS HANDLING IMPROVEMENTS VARIANCE AND BUDGET INCREASE

#### SUMMARY:

The Michelson Water Recycling Plant (MWRP) Solids Handling Improvements project will address mechanical and performance issues with the solids thickening and dewatering processes.

Staff recommends that the Board:

- Authorize a budget increase for Project 12555 in the amount of \$10,670,000, from \$1,065,000 to \$11,735,000; and
- Authorize the General Manager to approve Variance No. 1 with Carollo Engineers, Inc. in the amount of \$394,974 for additional engineering design services for the MWRP Solids Handling Improvements.

#### BACKGROUND:

IRWD's MWRP Biosolids Facility was commissioned and put into operation in the fall of 2020. Since then, staff have discovered operational, performance, and maintenance issues related to the thickening and dewatering processes. In May 2022, IRWD retained Carollo Engineers, Inc. to study the solids handling facility issues. The study documented issues faced by staff, identified potential causes, and developed solutions to implement to address these issues.

In October 2022, Carollo documented the study findings and recommendations in a technical memorandum. The key recommendations included improving the sludge feed consistency, increasing the thickened sludge concentration to the digesters, upsizing the digester feed pumps to handle thicker sludge, reducing clogging in the sludge lines, improving centrate drainage to protect dewatering centrifuges, and improvements to increase process instrumentation reliability.

In June 2025, IRWD retained Carollo to design the recommended Biosolids Facility Improvements. The scope of the design includes preparing drawings, technical specifications, and a project manual for construction bidding. Carollo has completed the preliminary design of the Project and will be submitting the 60% final design this month. To date, Carollo has spent approximately 80% of their current budget.

#### Design Agreement Variance No. 1:

During the preliminary design phase, it was discovered by staff that some changes to the original project scope were required to meet the overall Project objectives. The significant additional design elements are described as follows:

Consent Calendar: Michelson Water Recycling Plant Solids Handling Improvements Variance and Budget Increase

May 26, 2026

Page 2

- Add overflow protection and inter-tank opening slide gates to the primary sludge and waste activated sludge wet wells;
- Add electrically actuated valves for sludge recirculation; and
- Replace the Methane Phase Digester Recycled pumps.

Slide gates and overflow protection were added for the primary sludge, blended sludge, and waste activated sludge wet wells to allow for safer operation and maintenance access while maintaining process flow. Electrically actuated valves were proposed for the sludge recirculation process instead of manual valves for ease of operation, reduction of staff time, and to ensure all valves are operated correctly during sludge recirculation. Replacement of the Methane Phase Digester Recycle pumps was added because the pumps are obsolete and the manufacturer no longer supports the existing pump model to provide replacement of parts.

Work that is to be eliminated from the scope includes removing unnecessary field work and potholing, reducing the number of meetings, and the deleting proposed SCADA screen mockup related to the original System Simplification scope.

The proposed changes to the design scope of work are necessary to meet the operational and maintenance requirements, and ensure safe, long-term operability and reliability for the Biosolids Facility. The proposed design changes will modify 45 drawings and require 30 additional drawings, increasing the design schedule by three months. The revised schedule shows the final design submittal will be provided in October 2026. The negotiated total cost of Variance No. 1 is \$394,974 and it is provided as Exhibit "A". Staff has reviewed the negotiated variance cost proposal and scope of work and determined it to be fair and reasonable.

FISCAL IMPACTS:

Project 12555 is currently included in the FY 2025-26 Capital Budget. This project is funded 50% by Sewer Replacement Funds and 50% by Sewer New Capital funds. A budget increase is required to fund the design and construction phases as shown in the table below:

Project No.	Current Budget	Addition <Reduction>	Total Budget
12555	\$ 1,065,0000	\$ 10,670,000	\$11,735,000

ENVIRONMENTAL COMPLIANCE:

This project is subject to the California Environmental Quality Act (CEQA). In conformance with the California Code of Regulations Title 14, Chapter 3, Section 15004, the appropriate environmental document will be prepared when "meaningful information" becomes available. It is expected that preliminary analysis will lead to the preparation of a Notice of Exemption for the project as authorized under the California Code of Regulations, Title 14, Chapter 3, Section 15301 which provides exemption for minor alterations of existing public or private structures, facilities, mechanical equipment, or topographical features, involving negligible or no expansion of use beyond that existing at the time of the lead agency's determination.

Consent Calendar: Michelson Water Recycling Plant Solids Handling Improvements Variance  
and Budget Increase

May 26, 2026

Page 2

COMMITTEE STATUS:

This item was reviewed by the Engineering and Operations Committee on May 19, 2026.

RECOMMENDATION:

THAT THE BOARD AUTHORIZE A BUDGET INCREASE IN THE AMOUNT OF \$10,670,000, FROM \$1,065,000 TO \$11,735,000, AND AUTHORIZE THE GENERAL MANAGER TO APPROVE VARIANCE NO. 1 WITH CAROLLO ENGINEERS, INC. IN THE AMOUNT OF \$394,974 FOR ADDITIONAL ENGINEERING DESIGN SERVICES FOR THE MICHELSON WATER RECYCLING PLANT SOLIDS HANDLING IMPROVEMENTS, PROJECT 12555.

LIST OF EXHIBITS:

Exhibit "A" – Carollo Variance No. 1

Note: This page is intentionally left blank.

Exhibit "A"  
**IRVINE RANCH WATER DISTRICT**  
**PROFESSIONAL SERVICES VARIANCE**

Project Title: Irvine Ranch Water District Solids Handling Improvements Project  
 Project No.: 12555 Date: 4/27/2026  
 Purchase Order No.: \_\_\_\_\_ Variance No.: 1

Originator:  IRWD  ENGINEER/CONSULTANT  Other (Explain) \_\_\_\_\_

Description of Variance (*attach any back-up material*):

A combination of added and deducted scope from the solids handling improvements project. Major additive elements include:  
Overflow and gates for PS/WAS Wetwells, feasibility assessment of PS/WAS hatches, electrical actuators for sludge recirculation,  
Replacing methane phase digested sludge recycle pumps, recycle water improvements, and wharf hydrants for centrate SBR.

Engineering & Management Cost Impact:

Classification	Manhours	Billing Rate	Labor \$	Direct Costs	Subcon. \$	Total \$
Project Management	107	274.69	29,392	100	0	29,492
Preliminary Design Report	568	236.14	134,129	-100	-19,391	114,638
Final Design	1079	232.48	250,844	0	0	250,844
<b>Total \$ =</b>						<b>394,974</b>

Schedule Impact:

Task No.	Task Description	Original Schedule	Schedule Variance	New Schedule
2	Preliminary Design Report	11/3/2025	130 calendar days	3/13/2026
3	Final Design	6/15/2026	112 calendar days	10/5/2026
4	Bid Period Support	8/3/2026	120 calendar days	12/1/2026

Required Approval Determination:

Total Original Contract	<u>\$1,052,221</u>	<input type="checkbox"/> Director: Cumulative total of Variances less than or equal to \$75,000.
Previous Variances \$0		
This Variance	<u>\$394,974</u>	<input type="checkbox"/> Executive Director: Cumulative total of Variances less than or equal to \$125,000.
Total Sum of Variances	<u>\$394,974</u>	
New Contract Amount	<u>\$1,447,195</u>	<input type="checkbox"/> General Manager: Cumulative total of Variances less than or equal to \$200,000.
Percentage of Total Variances to Original Contract	<u>38 %</u>	<input checked="" type="checkbox"/> Board: Cumulative total of Variances greater than \$200,000.

ENGINEER/CONSULTANT: Carollo Engineers, Inc IRVINE RANCH WATER DISTRICT  
 Company Name

Rashi Gupta (Apr 28, 2026 19:01:23 PDT)  
 Project Engineer/Manager Rashi Gupta Date Apr 28, 2026

Kevin L. Burton A.M. Date 5/11/26  
 Department Director

Eric M. Mills  
 Engineer's/Consultant's Management Date Apr 28, 2026  
 Eric M. Mills

General Manager/Board Date





## Scope of Work

### Irvine Ranch Water District Task Order No. 2 – Solids Handling Improvements Project Amendment

#### BACKGROUND

Irvine Ranch Water District (DISTRICT) has requested changes to the original scope of work for the Michelson Water Reclamation Plant (MWRP) Solids Handling Improvement Project Task Order No.1 (TO1). Some changes are deductive and some are additive. The requested changes comprise Task Order No.2 (TO2) and are summarized below:

#### Deductive:

- Conducting two, four-hour, site visit to interview staff and gather more information on the operations of the solids systems to enable the ENGINEER to suggest system simplification strategies.
- Preparing one SCADA screen mockup to show a more tangible example of SCADA simplification suggestions that would be made by the ENGINEER.
- Scaffolding effort provided by IRWD staff, instead of Jamison Engineering Contractors, during V&A's centrate pipe inspection
- Potholing effort by Underground Solutions Inc.
- Remaining effort for the detailed design of the digester gas condensate modifications.

#### Additive:

- Adding the following provisions to the scope of the PS/WAS wet wells modifications:
  - Adding overflow protection to each wet well.
  - Isolating inter-tank openings with manual gates.
  - Routing the existing WAS centrate pipe to an additional wet well.
  - Isolating the existing TS wet well overflow piping with a manual valve.
- Assessing the feasibility of providing access hatches at the PS/WAS wet wells.
- Providing electrically actuated valves, rather than manual valves, to enable automated backflushing for the acid digester feed piping.
- Installing isolation valves and pressure gauges at each of the thickening and dewatering centrifuges recycle water (RW) feed pipes.
- Replacing obsolete Methane Phase Digester Recycle pumps with new model (2000 series).
- Developing PS/WAS wet wells' mixers replacement cost.
- Evaluating whether 120V valves can be used to actuate sludge recirculation valves instead of 480V, which is the standard.
- Addition of two wharf hydrants and associated water piping at the centrate SBRs to facilitate hose down/housekeeping.

- Upsizing existing slop flush lines to 1.5" (includes upsizing the solenoid valves) at the three dewatering centrifuges.
- Developing (3) Process Flow Diagram (PFD) drawings to facilitate staff understanding of the system.
- Conducting a Programming Review Meeting at 90% design to discuss programming modifications with DISTRICT staff.

ENGINEER estimates that TO2, will add 30 new sheets and add additional information to 45 sheets. A complete list of the two sets of drawings is presented in Appendix A: New Drawings resulting from TO2, and Drawings impacted by TO2.

Below are more detailed descriptions of the deductive items for which the project will be credited and the additive items that comprise the scope of work for TO2.

### **PROJECT CREDIT FOR DEDUCTIVE ITEMS**

The original scope of *Task Order 1: Task 2 Preliminary Design, Subtask 206 Improvements Recommendations - System Simplification and Dryer System Reliability* included:

1. Conducting three, four-hour, site visits to interview staff and collect more information on the operations of the solids systems (both at the field, and through SCADA) in order for ENGINEER to suggest simplification strategies.
2. Preparing one SCADA screen mockup to show a more tangible example of SCADA simplification suggestions that would be made by ENGINEER.

ENGINEER conducted only one of the planned site visits. ENGINEER did not conduct two site visits since it was not necessary. Additionally, the DISTRICT informed ENGINEER that they did not wish to have another SCADA site visit/discussion and directed ENGINEER not to prepare the SCADA mockup. This effort is delineated in the following subtasks:

- Task 202: Site Visits, Staff Feedback, and Documentation Review
- Task 206A: Improvements Recommendations - System Simplification and Dryer System Reliability (SCADA Mockup)

During preliminary design, Carollo contracted the service of two subconsultants: V&A to conduct pipe inspection on the centrate pipes, and Underground Solutions to pothole the condensate and centrate pipes areas. V&A intended to use a subcontractor, Jamison Engineering Contractors, to provide scaffolding to access the centrate pipes during pipe inspection. Instead, V&A used scaffolding erected by IRWD staff and did not need to utilize Jamison Engineering Contractors. Additionally, the ENGINEER and the DISTRICT decided that potholing was not necessary to construct the new centrate and condensate pipes. The credit associated with the unused balance from V&A's contract along with the full balance from Underground Solutions, including ENGINEER'S 5% markup, is delineated in the following subtask:

- Task 205: Improvements Recommendations - Field Investigations

On 4/3/26, the DISTRICT requested that the digester gas condensate modifications portion of the project is removed from the scope. Effort associated with the preliminary design as well as a portion of

the 60% design has been expended. The credit associated with the remaining portion of 60% design, as well as the full 90% and final design efforts is delineated in the following subtask:

- Tasks 303-305: Digester Gas Condensate Modifications

### **SCOPE OF WORK FOR ADDITIVE BASE ITEMS**

The scope of work associated with the additive items in TO2 is summarized below.

#### **TASK 1 – PROJECT MANAGEMENT**

The ENGINEER will perform various project management and monitoring activities throughout the Project duration, as delineated in the following subtasks.

- Tasks 104 and 105: The project schedule has been extended by 3 months. Project management activities, including additional biweekly and monthly progress reports and team management are necessary. This task includes additional effort associated with those activities as described in TO1.
- 106: Programming Review Meeting – During the 90 percent design stage, ENGINEER will present to the DISTRICT major changes to the programming logic resulting from the new control strategies. The purpose of this meeting is to provide DISTRICT staff with an additional opportunity to review the programming changes, engage with ENGINEER, and provide feedback prior to final design.

#### Task 1 Deliverables:

- As presented in Task Order 1.
- Programming Review Meeting agenda and minutes (PDF format).

#### Assumptions:

- Programming Review Meeting will be 2 hours in duration and up to four (4) team members will participate in the meeting. Meeting will be hybrid.

#### **TASK 2 – PRELIMINARY DESIGN REPORT (PDR)**

The ENGINEER updated the PDR to include:

- The following PS/WAS wet wells modifications:
  - Adding overflow protection to each wet well.
  - Isolating inter-tank openings with manual gates.
  - Routing the existing WAS centrate pipe to an additional wet well.
  - Isolating the existing TS wet well overflow piping with a manual valve.
- Feasibility assessment of access hatches at the PS/WAS wet wells.
- Electrically actuated valves in sludge recirculation loop.
- Isolation valves and pressure gauges at each of the thickening and dewatering centrifuges RW feed pipes.
- Replacement of obsolete Methane Phase Digester Recycle pumps with new model (2000 series).

- Evaluation of whether 120V valves can be used to actuate sludge recirculation valves instead of 480V, which is standard for the size valves to be actuated. Evaluation included consultation with valve and actuator manufacturers as well as internal experts to assess suitability and risks because 120 V actuators are not typically used for 4” and 8” plug valves.

The preliminary design effort is delineated in the following subtasks for clarity:

- Task 204: Improvements Recommendations
- Task 212: Feasibility Assessment of Adding Hatches at PS/WAS Wet Wells

There was an additional task that DISTRICT requested the ENGINEER complete that was not part of the PDR, which is:

- Evaluating PS/WAS wet wells’ mixers replacement cost.

Effort for this task is included in the following subtask:

- Task 204: Improvements Recommendations

Task 2 Deliverables:

As presented in Task Order 1.

Assumptions:

- Preliminary design drawings will not include PS/WAS Wet Well hatches.

**TASK 3 – FINAL DESIGN**

The ENGINEER will include the following scope additions in the final design documents:

- The following PS/WAS wet wells modifications:
  - Adding overflow protection to each wet well.
  - Isolating inter-tank openings with manual gates.
  - Routing the existing WAS centrate pipe to an additional wet well.
  - Isolating the existing TS wet well overflow piping with a manual valve.
- Isolation valves and pressure gauges at each of the thickening and dewatering centrifuges recycle water (RW) feed pipes.
- Replacement of obsolete Methane Phase Digester Recycle pumps with new model (2000 series).
- Addition of two wharf hydrants and associated water piping at the centrate SBRs to facilitate hose down/housekeeping.
- Providing electrically actuated valves, rather than manual valves, to enable automated backflushing for the acid digester feed piping.
- Upsizing the existing slop flush lines to 1.5” (includes upsizing the solenoid valves) at the three dewatering centrifuges. See assumptions for critical assumptions for this task.
- Developing (3) Process Flow Diagram drawings to assist with staff understanding of overall systems.

The final design effort is delineated in the following subtasks.

- Task 303 60% Draft Submittal
- Task 304 90% Design Submittal
- Task 305 Final Design Submittal

### Task 3 Deliverables:

As presented in Task Order 1.

### Assumptions:

- The following assumptions apply to the hydrant, and associated water piping to facilitate washdown and housekeeping at the centrate SBRs:
  - Provisions will consist of a new 4" Utility Water (UW2) exposed pipe connecting into an existing 6" UW2 pipe located in the polymer feeder/blender area in the SHB. The new UW2 pipe will feed two 2 ½" wharf head hydrants, located on each side of the deck, and intended for cleaning and hosing down of tanks and pit. Temporary hoses, provided by the DISTRICT, would be used to connect to the hydrant.
  - No potholing is required since civil as-built drawings do not show any buried utilities or pipes between the yard connection and the centrate SBRs.
  - Plumbing drawings will not be produced. Modifications will be captured on civil and process/mechanical drawings only.
  - All provisions are manual.
  - Sufficient water pressure is available. No booster pumps will be required.
  - Sufficient water supply is available to cover other processes connected into the existing 6" UW2 pipe when the hydrant is being used to fully clean the tanks.
  - No backflow preventers will be needed.
- The following assumptions apply to the RW modifications:
  - New valves are assumed to be manual valves with no limit switches. No additional electrical or instrumentation drawing are assumed.
  - Some of the existing RW piping is shown on the plumbing plan drawings and some RW piping is shown on the mechanical drawings in MWRP Biosolids and Energy Recovery Facility as-builts. For simplicity, ENGINEER will show all RW modifications on mechanical drawings only.
  - The RW modifications are assumed to consist of 1 isolation valve and 1 pressure gauge at the thickening and dewatering centrifuges RW headers (7 locations: 4 at the thickening centrifuges, and 3 at the dewatering centrifuges) in the drawings assumed for this project.
- The following are Electrical, Instrumentation and Controls related assumptions:
  - Methane Phase Digested Sludge Recycle Pump VFDs will not be replaced.
  - New cable and conduit schedule drawings will be submitted to capture the new work. Original as-built drawings showing cable and conduit schedules that do not contain new work will not be modified.
  - Original MCC elevation as-built drawings will not be modified. The labels on the as-built MCC elevation drawings do not accurately reflect field labels and it will be a significant

effort to correct them. These drawings are not critical for the planned modifications. No corrections to existing bucket designations are included. Drawings will be used to show changes to MCC elevations using photos.

- No single line demolition drawings are included. Electrical single line drawings are sufficient to show the electrical scope.
- Discrepancies between existing as-built drawings and field conditions will not be corrected on drawings if corrections do not impact new work.
- Panels' bill of material (BOM) drawings will show items and quantities related to the new work only for clarity.
- No effort to correct as-builts to match field conditions if corrections do not affect the current design or the Contractor's work.
- Process flow diagrams (PFDs) are intended to be simplified schematics including only essential information for overall process understanding. Not all valves, flush locations, etc. will be shown on the PFDs. However, the P&IDs included in the base project will reflect these details.
- No P&IDs are included for the upsizing of the 1.5-inch slop line solenoid valves. All work will be done on the mechanical, electrical (conduit) and area plan drawings to show the new solenoid and the replacement of the wiring.

## **SCHEDULE**

The project schedule is updated to the following:

- Draft PDR (to DISTRICT): 1/30/2026
- Final PDR (to DISTRICT): 3/13/2026
- 60% Design Submittal (to DISTRICT): 5/11/2026
- 90% Design Submittal (to DISTRICT): 8/10/2026
- Final Design Submittal (to DISTRICT): 10/5/2026
- Bid Opening: 12/1/2026

## **ESTIMATED EFFORT**

As shown in Exhibit A:

- Effort already expended on TO2 items through the PDR stage is \$114,638
- The base fee for this Task Order No.2 is \$394,974.

## **OTHER ASSUMPTIONS**

In addition to the assumptions noted within the Scope of Work above, the following assumptions have been made in developing this Scope of Work and associated level of effort:

- One DISTRICT point of contact (POC) made available and accessible to ENGINEER staff throughout project duration.
- DISTRICT staff may be asked to provide existing system information (performance data, standard operating procedures, schematics, drawings, existing equipment information, etc.), clarification on items that are unclear and to provide photographs or additional information on select items if needed.

- DISTRICT shall furnish ENGINEER available studies, reports and other data pertinent to ENGINEER's services; obtain or authorize ENGINEER to obtain or provide additional reports and data as required; furnish to ENGINEER services of others required for the performance of ENGINEER's services hereunder, and ENGINEER shall be entitled to use and rely upon all such information and services provided by DISTRICT or others in performing ENGINEER's services under this Agreement.
- ENGINEER has no control over the cost of labor, materials, equipment or services furnished by others, over the incoming water quality and/or quantity, or over the way DISTRICT's plant and/or associated processes are operated and/or maintained. Data projections and estimates are based on ENGINEER's opinion based on experience and judgment. ENGINEER cannot and does not guarantee that actual costs and/or quantities realized will not vary from the data projections and estimates prepared by ENGINEER and ENGINEER will not be liable to and/or indemnify DISTRICT and/or any third party related to any inconsistencies between ENGINEER's data projections and estimates and actual costs and/or quantities realized by DISTRICT and/or any third party in the future, except to the extent such inconsistencies are caused by ENGINEER's negligent performance hereunder.
- The services to be performed by ENGINEER are intended solely for the benefit of DISTRICT. No person or entity not a signatory to this Agreement shall be entitled to rely on ENGINEER's performance of its services hereunder, and no right to assert a claim against ENGINEER by assignment of indemnity rights or otherwise shall accrue to a third party as a result of this Agreement or the performance of ENGINEER's services hereunder.

# Appendix A

## New and Planned Drawings Impacted by T02

### New Drawings:

Sheet Count	Discipline	Sheet Title
1	General	PROCESS FLOW DIAGRAM 1 - PLANT CONNECTIONS & THICKENING
2	General	PROCESS FLOW DIAGRAM 2 - DIGESTION
3	General	SLUDGE RECIRCULATION PROCESS FLOW DIAGRAM
4	Structural	SOLIDS HANDLING BUILDING - DETAILS
5	Structural	SOLIDS HANDLING BUILDING - DETAILS
6	Electrical	SOLIDS HANDLING BUILDING - PANELBOARD SCHEDULES
7	Electrical	DIGESTER CONTROL BUILDING - PANELBOARD SCHEDULES
8	Electrical	DIGESTER CONTROL BUILDING - PANELBOARD SCHEDULES
9	Electrical	CABLE AND CONDUIT SCHEDULES 2
10	Electrical	CABLE AND CONDUIT SCHEDULES 3
11	Electrical	CABLE AND CONDUIT SCHEDULES 4
12	Electrical	SOLIDS HANDLING BUILDING - MCC ELEVATIONS
13	Electrical	DIGESTER CONTROL BUILDING - MCC-4102 ONE LINE DIAGRAMS
14	Electrical	DIGESTER CONTROL BUILDING - MCC-4102 ONE LINE DIAGRAMS (CONT.)
15	Electrical	DIGESTER CONTROL BUILDING - MCC-4103 ONE LINE DIAGRAMS
16	Electrical	DIGESTER CONTROL BUILDING - MCC-4103 ONE LINE DIAGRAMS (CONT.)
17	Electrical	DIGESTER CONTROL BUILDING - MCC ELEVATIONS

18	Electrical	SCHEMATIC DIAGRAMS
19	Electrical	DIGESTER CONTROL BUILDING - GROUND LEVEL POWER PLAN 5
20	Electrical	DIGESTER CONTROL BUILDING - GROUND LEVEL POWER PLAN 6
21	Electrical	DIGESTER CONTROL BUILDING - GROUND LEVEL CONTROL AND SIGNAL PLAN 5
22	Electrical	DIGESTER CONTROL BUILDING - GROUND LEVEL CONTROL AND SIGNAL PLAN 6
23	Electrical	DIGESTER CONTROL BUILDING - BASEMENT LEVEL POWER PLAN 5
24	Electrical	DIGESTER CONTROL BUILDING - BASEMENT LEVEL CONTROL AND SIGNAL PLAN 5
25	Instrumentation	P&ID SLUDGE SCREENS
26	Instrumentation	P&ID METHANE PHASE DIGESTED SLUDGE RECYCLE PUMP
27	Instrumentation	INTERNAL PANEL ELEVATION
28	Instrumentation	RIO PANEL RIO-2002 BILL OF MATERIAL
29	Instrumentation	INTERNAL PANEL ELEVATION
30	Instrumentation	RIO PANEL RIO-3101 BILL OF MATERIAL

**Modified Drawings Impacted by TO2:**

Sheet Count	Discipline	Sheet Title
1	Civil	OVERALL YARD PIPING PLAN
2	Civil	YARD PIPING PLAN
3	Civil	CIVIL TYPICAL DETAILS 1
4	Demolition	SOLIDS HANDLING BUILDING - ENLARGED PIPING PLAN EL 36 TO 53 - AREA 3
5	Demolition	SOLIDS HANDLING BUILDING - SECTIONS
6	Demolition	SOLIDS HANDLING BUILDING - THICKENING CENTRIFUGE PLAN & SECTIONS
7	Demolition	SOLIDS HANDLING BUILDING - DEWATERING CENTRIFUGE PLAN & SECTIONS
8	Demolition	DIGESTER CONTROL BUILDING - DEMOLITION ENLARGED BASEMENT LEVEL PLAN
9	Structural	SOLIDS HANDLING BUILDING - DETAILS
10	Structural	CENTRATE TREATMENT – DETAILS

11	Mechanical	SOLIDS HANDLING BUILDING - FIRST FLOOR ENLARGED PLAN - AREA 3
12	Mechanical	SOLIDS HANDLING BUILDING - SECOND FLOOR ENLARGED PLAN - AREA 3
13	Mechanical	SOLIDS HANDLING BUILDING - SECOND FLOOR ENLARGED PLAN - AREA 4
14	Mechanical	SOLIDS HANDLING BUILDING - ENLARGED PIPING PLAN EL 30 TO 53 - AREA 2
15	Mechanical	SOLIDS HANDLING BUILDING - THICKENING CENTRIFUGE PLAN AND SECTIONS
16	Mechanical	SOLIDS HANDLING BUILDING - SECTIONS
17	Mechanical	SOLIDS HANDLING BUILDING - SECTIONS
18	Mechanical	SOLIDS HANDLING BUILDING - SECTIONS
19	Mechanical	SOLIDS HANDLING BUILDING - DETAILS
20	Mechanical	DIGESTER CONTROL BUILDING - ENLARGED BASEMENT LEVEL PLAN
21	Mechanical	DIGESTER CONTROL BUILDING - SECTION
22	Mechanical	DIGESTER CONTROL BUILDING - DETAILS
23	Mechanical	CENTRATE TREATMENT - TOP PLAN
24	Electrical	SOLIDS HANDLING BUILDING - PANELBOARD SCHEDULES
25	Electrical	CABLE AND CONDUIT SCHEDULES 1
26	Electrical	SOLIDS HANDLING BUILDING - ENLARGED FIRST FLOOR POWER PLAN 1
27	Electrical	SOLIDS HANDLING BUILDING - ENLARGED FIRST FLOOR POWER PLAN 6
28	Electrical	SOLIDS HANDLING BUILDING - ENLARGED FIRST FLOOR CTRL & SIG PLAN 1
29	Electrical	SOLIDS HANDLING BUILDING - ENLARGED FIRST FLOOR CTRL & SIG PLAN 5
30	Electrical	SOLIDS HANDLING BUILDING - ENLARGED FIRST FLOOR CTRL & SIG PLAN 6
31	Electrical	SOLIDS HANDLING BUILDING - ENLARGED SECOND FLOOR CTRL & SIG PLAN 4
32	Electrical	SOLIDS HANDLING BUILDING - ENLARGED DEWATERING CENTRIFUGE PLAN
33	Electrical	SOLIDS HANDLING BUILDING - ENLARGED DEWATERING CENTRIFUGE PLAN
34	Instrumentation	P&ID SLUDGE WETWELLS
35	Instrumentation	P&ID THICKENING CENTRIFUGE NO. 1
36	Instrumentation	P&ID THICKENING CENTRIFUGE NO. 2
37	Instrumentation	P&ID THICKENING CENTRIFUGE NO. 3
38	Instrumentation	P&ID THICKENING CENTRIFUGE NO. 4
39	Instrumentation	P&ID THICKENED SLUDGE WETWELL
40	Instrumentation	P&ID DIGESTER FEED PUMPS (SHEET 1 OF 4)
41	Instrumentation	P&ID DIGESTER FEED PUMPS (SHEET 2 OF 4)
42	Instrumentation	P&ID DIGESTER FEED PUMPS (SHEET 3 OF 4)

<b>43</b>	Instrumentation	P&ID DIGESTER FEED PUMPS (SHEET 4 OF 4)
<b>44</b>	Instrumentation	P&ID ACID PHASE DIGESTER NO. 1 SLUDGE FEED, MIXING AND LOCAL GAS
<b>45</b>	Instrumentation	P&ID ACID PHASE SLUDGE TRANSFER PUMPS



May 26, 2026

Prepared by: T. Edwards / E. Akiyoshi

Submitted by: K. Burton

Approved by: Paul A. Cook 

## CONSENT CALENDAR

### FISCAL YEAR 2026-27 PIPELINE REPLACEMENT PROJECT ADDITIONS

#### SUMMARY:

IRWD's new pressure pipeline risk model was used to create and prioritize new capital improvement projects for fiscal year (FY) 2026-27 to support its level of service goals. The projects below includes approximately three miles of pipeline replacements. These projects reduce total system risk, with the goal of staying with IRWD's annual break rate – defined as “breaks per 100-miles” (BPHM) – service levels by targeting the highest likelihood of failure pipelines.

Staff recommends that the Board:

- Authorize the addition of the Warner Avenue Recycled Water Pipeline Replacement, Project 13560 in the amount of \$2,310,000 to the FY 2026-27 Capital Budget;
- Authorize the addition of the Portola Springs Domestic Water Pipeline Rehabilitation, Project 13561 in the amount of \$3,778,000 to the FY 2026-27 Capital Budget;
- Authorize the addition of the Portola Springs Recycled Water Pipeline Rehabilitation, Project 13562 in the amount of \$3,512,000 to the FY 2026-27 Capital Budget; and
- Authorize the addition of the University Park Domestic Water Pipeline Replacement, Project 13563 in the amount of \$4,480,000 to the FY 2026-27 Capital Budget.

#### BACKGROUND:

In 2026, IRWD completed the Capital Improvement Plan and Asset Management for Domestic and Recycled Water Pipelines Project, which included a new risk model to assist with the identification and prioritization of capital projects. Additionally, IRWD seeks to stay within its current pipe break rate level of service (i.e., two BPHM for the domestic system and six BPHM for the recycled system).

A general pipeline replacement plan was developed for the next 30 years based on the risk model and level of service goals. The pipeline replacement program consists of three miles of pipeline for the next five years, six miles of pipeline per year for the following 10 years, and nine miles of pipeline per year for the following 15 years. The risk model was used to prioritize and identify three miles of pipelines for replacement and package the pipelines into projects.

To achieve these goals, staff is recommending that the District proceed with the following four pipeline replacement projects: the Warner Avenue, Portola Springs (Domestic and Recycled Water), and University Park pipeline replacements. A location map of these four projects is provided as Exhibit “A.”

FISCAL IMPACTS:

Staff recommends the addition of Projects 13560, 13561, 13562, and 13563, which will be funded by the respective Domestic Water and Recycled Water Replacement Funds, to the FY 2026-27 Capital Budget as follows:

<u>Project No.</u>	<u>Current Budget</u>	<u>Addition &lt;Reduction&gt;</u>	<u>Total Budget</u>
13560	\$0	\$2,310,000	\$2,310,000
13561	\$0	\$3,778,000	\$3,778,000
13562	\$0	\$3,512,000	\$3,512,000
13563	\$0	\$4,480,000	\$4,480,000
Total	\$0	\$14,080,000	\$14,080,000

ENVIRONMENTAL COMPLIANCE:

The Projects are subject to the California Environmental Quality Act (CEQA). In conformance with the California Code of Regulations Title 14, Chapter 3, Section 15004, the appropriate environmental document(s) will be prepared when "meaningful information" becomes available.

COMMITTEE STATUS:

This item was reviewed by the Engineering and Operations Committee on May 19, 2026.

RECOMMENDATION:

THAT THE BOARD AUTHORIZE THE ADDITION OF THE WARNER AVENUE RECYCLED WATER PIPELINE REPLACEMENT, PROJECT 13560 IN THE AMOUNT OF \$2,310,000 TO THE FY 2026-27 CAPITAL BUDGET; AUTHORIZE THE ADDITION OF THE PORTOLA SPRINGS DOMESTIC WATER PIPELINE REHABILITATION, PROJECT 13651 IN THE AMOUNT OF \$3,778,000 TO THE FY 2026-27 CAPITAL BUDGET; AUTHORIZE THE ADDITION OF THE PORTOLA SPRINGS RECYCLED WATER PIPELINE REHABILITATION, PROJECT 13562 IN THE AMOUNT OF \$3,512,000 TO THE FY 2026-27 CAPITAL BUDGET; AND AUTHORIZE THE ADDITION OF THE UNIVERSITY PARK DOMESTIC WATER PIPELINE REPLACEMENT, PROJECT 13563 IN THE AMOUNT OF \$4,480,000 TO THE FY 2026-27 CAPITAL BUDGET.

LIST OF EXHIBITS:

Exhibit "A" – Location Map

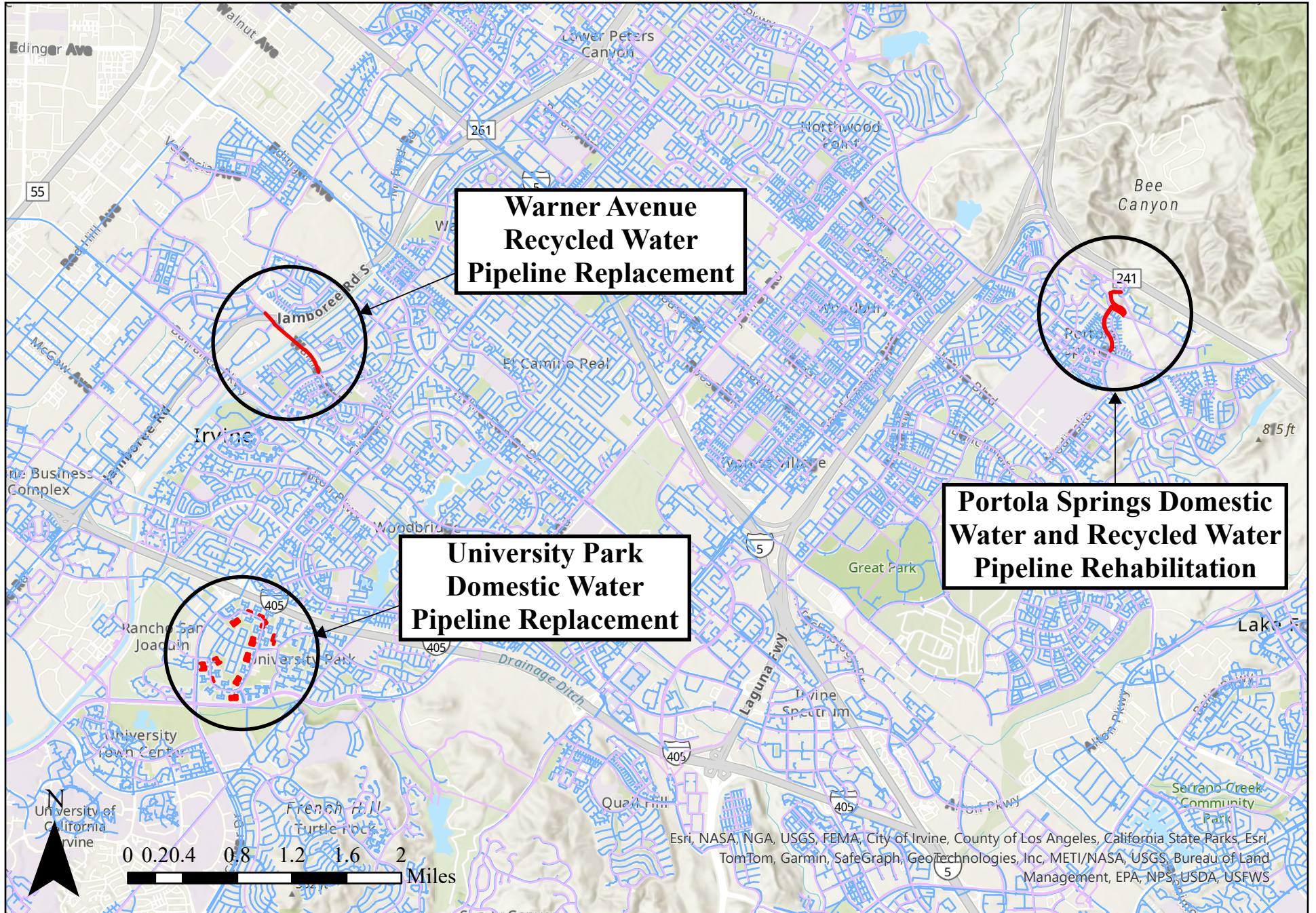

# FY 2026-27 PIPELINE PROJECT ADDITIONS LOCATION MAP

Note: This page is intentionally left blank.

May 26, 2026  
Prepared by: M. Robinson / E. Akiyoshi  
Submitted by: K. Burton  
Approved by: Paul A. Cook *PA.Cook*

## CONSENT CALENDAR

### FISCAL YEAR 2025-26 GENERAL REPLACEMENTS AND MODIFICATIONS PROJECTS BUDGET INCREASES

#### SUMMARY:

The Fiscal Year (FY) 2025-26 General System Replacements and Modifications projects have experienced increased spending associated with small construction projects, pipeline repairs, and general mechanical, electrical, and construction services expenditures.

Staff recommends that the Board:

- Authorize a budget increase to Project 12521, FY 2025-26 Domestic Water General System Replacements and Modifications, in the amount of \$1,417,000, from \$6,283,000 to \$7,700,000;
- Authorize a budget increase to Project 12523, FY 2025-26 Recycled Water General System Replacements and Modifications, in the amount of \$497,000, from \$2,103,000 to \$2,600,000; and
- Authorize a budget increase to Project 12525, FY 2025-26 Sewer General System Replacements and Modifications, in the amount of \$1,315,000, from \$1,785,000 to \$3,100,000.

#### BACKGROUND:

The General System Replacements and Modifications projects encompass a variety of capital activities, including small construction projects at MWRP and the Biosolids Facilities, emergency pipeline repairs, mechanical and electrical asset replacements, industrial coatings repairs, meter upgrades, and reimbursement for raising valves and manholes to grade following city street rehabilitation projects. Due to increased activity and expenditures in FY 2025-26, staff recommends budget increases of \$1,417,000 for Project 12521, \$497,000 for Project 12523, and \$1,315,000 for Project 12525.

#### FISCAL IMPACTS:

Projects 12521, 12523, and 12525 are included in the FY 2025-26 Capital Budget and require budget increases as follows:

Project No.	Current Budget	Addition <Reduction>	Total Budget
12521	\$6,283,000	\$1,417,000	\$7,700,000
12523	\$2,103,000	\$497,000	\$2,600,000
12525	\$1,785,000	\$1,315,000	\$3,100,000
Total	\$10,171,000	\$3,229,000	\$13,400,000

ENVIRONMENTAL COMPLIANCE:

This study is exempt from the California Environmental Quality Act as authorized under the California Code of Regulations, Title 14, Chapter 3, Section 15262 which provides exemption for planning studies.

COMMITTEE STATUS:

This item was reviewed by the Engineering and Operations Committee on May 19, 2026.

RECOMMENDATION:

THAT THE BOARD AUTHORIZE A BUDGET INCREASE FOR PROJECT 12521 IN THE AMOUNT OF \$1,417,000, FROM \$6,283,000 TO \$7,700,000; AUTHORIZE A BUDGET INCREASE FOR PROJECT 12523 IN THE AMOUNT OF \$497,000, FROM \$2,103,000 TO \$2,600,000; AND AUTHORIZE A BUDGET INCREASE FOR PROJECT 12525 IN THE AMOUNT OF \$1,315,000, FROM \$1,785,000 TO \$3,100,000, FOR THE FISCAL YEAR 2025-26 GENERAL SYSTEM REPLACEMENTS AND MODIFICATIONS PROJECTS.

LIST OF EXHIBITS:

None.

May 26, 2026

Prepared by: L. Kaneshiro

Submitted by: N. Adly

Approved by: Paul A. Cook 

## CONSENT CALENDAR

### ESRI GIS ENTERPRISE AGREEMENT, AMENDMENT NO. 1

#### SUMMARY:

IRWD utilizes Esri Geographic Information System (GIS) software to support critical District operations including asset management, customer service, utility network management, field mobility, engineering, planning, emergency operations, dashboards, and public information services. The current Esri Enterprise Agreement provides necessary software maintenance, updates, technical support, and enterprise licensing to maintain reliable and secure GIS technologies throughout the District. The proposed Amendment No. 1 continues the current agreement and updates the Esri software licensing, user subscriptions, and support services.

Staff recommends that the Board authorize the General Manager to execute Amendment No. 1 to Esri Enterprise Agreement No. 00315535.0 to add \$750,000 and extend the term by three years, from May 23, 2026 through May 22, 2029.

#### BACKGROUND:

IRWD uses Esri GIS software as the enterprise platform for the District's spatial information needs, including business and operational support for asset management, customer service, utility network management, field mobility, engineering, planning, emergency operations, dashboards, and public information services. At its meeting on May 22, 2023, the Board approved the current agreement, which provides necessary Esri software maintenance, updates, technical support, and enterprise licensing to maintain reliable and secure GIS operations. The current agreement needs to be continued and updated to support IRWD's expanded use of GIS technologies across multiple departments, increased adoption of GIS applications by staff, expanded dashboard and operational reporting capabilities, and implementation of new GIS capabilities.

The proposed Amendment will extend the current agreement's term by three years and be updated to support IRWD's growing GIS needs. The Amendment increases user licensing quantities, supports the new Utility Network, which is an advanced system of record for water, sewer, recycled water, and infrastructure assets, and provides new GIS products, such as ArcGIS Velocity, which is a real-time data processing and analytics platform that will support situational awareness during emergency operations. The Amendment also includes licensing and support for the District's enterprise GIS infrastructure in the new managed cloud environment. Esri User Conference passes are also included for on-going staff development, training, and information about future GIS technologies. The total cost of the Amendment is \$750,000 for three years. The proposed Amendment, which includes the complete list of IRWD's Esri Enterprise Agreement products and services, is provided as Exhibit "A".

**FISCAL IMPACTS:**

The Esri Enterprise Agreement is included in the Information Technology Operating Budget, Department 250, Account 585005. The cost breakdown is shown on the table below.

<u>Fiscal Year</u>	<u>Agreement Fee</u>
2026-2027	\$250,000
2027-2028	\$250,000
2028-2029	\$250,000
<b>Total</b>	<b>\$750,000</b>

**ENVIRONMENTAL COMPLIANCE:**

This item is not a project as defined in the California Environmental Quality Act Code of Regulations, Title 14, Chapter 3, Section 15378.

**COMMITTEE STATUS:**

This item was not reviewed by a Board Committee.

**RECOMMENDATION:**

THAT THE BOARD AUTHORIZE THE GENERAL MANAGER TO EXECUTE AMENDMENT NO. 1 TO ESRI ENTERPRISE AGREEMENT NO. 00315535.0 TO ADD \$750,000 AND EXTEND THE TERM BY THREE YEARS, FROM MAY 23, 2026, THROUGH MAY 22, 2029.

**LIST OF EXHIBITS:**

Exhibit "A" – Amendment No. 1 to Enterprise Agreement No. 00315535.0

## Amendment No. 1 To Enterprise Agreement No. 00315535.0

---

This Amendment No. 1 (this "**Amendment No. 1**") to Enterprise Agreement No. 00315535.0 is hereby entered into by and between **Irvine Ranch Water District** ("**Customer**") and **Environmental Research Institute, Inc.** ("**Esri**").

**WHEREAS**, Esri and Customer entered into Enterprise Agreement No. 00315535.0 with an Effective Date of May 23, 2023 (hereinafter the "**EA**");

**WHEREAS**, Esri and Customer desire to amend the EA to (i) extend the Term of the EA for three (3) years, beginning on May 23, 2026 and ending on May 22, 2029 (the "**Amendment No. 1 Renewal Term**"), (ii) update 'Appendix A – Products and Deployment Schedule' and 'Appendix B - EA Fee Schedule' attached to the EA;

**NOW THEREFORE**, Esri and Customer agree that this Amendment No. 1, when signed by the parties, shall effect the following modifications to the EA:

1. The following sentence is hereby added to the end of Section 7.1 – Term of the EA:

*"The Amendment No. 1 Renewal Term shall be for three (3) years, beginning on May 23, 2026, and ending on May 22, 2029, unless this EA is terminated earlier as provided herein."*

2. Section 8.1 – Esri Confidential Information is hereby modified to read as follows:

Section 8.1 – Esri Confidential Information. Subject to the State of California Records Act or similar regulations enacted by Customer, the EA Fee and list of EA Products are confidential and proprietary information of Esri. To the extent that any disclosures of the EA Fee or list of EA Products may be required by the State of California Records Act law or by similar regulation enacted by the Customer, Customer shall inform Esri of the requested disclosure, with a reasonable description of the requested disclosure and identification of the requester, in sufficient time for Esri to assert any objection Esri may have to such disclosure with the appropriate administrative or judicial body. Except as provided herein (i.e., the State of California Records Act or similar regulations enacted by Customer), Customer shall not disclose the EA Fee or list of EA Products to any third party without Esri's prior written consent. Disclosure may be made only to those Customer employees, contractors, or consultants of Customer (e.g., outside counsel or accountants) who have a need to know to perform their duties or work on behalf of Customer and have an obligation of confidentiality. No other portions of the EA may be disclosed to a contractor or consultant.

3. 'Appendix A – Products and Deployment Schedule' attached to the EA is hereby deleted in its entirety and shall be replaced with 'Appendix A – Products and Deployment Schedule' attached this Amendment No. 1.
4. 'Appendix B – EA Fee Schedule' attached to the EA is hereby deleted in its entirety and shall be replaced with 'Appendix B – EA Fee Schedule' attached this Amendment No. 1.

Except as may be specifically modified by this Amendment No. 1, all other terms and conditions of the EA and any Amendment(s) or Addendum(s) thereto constitute the entire agreement between the parties and superseded all prior and contemporaneous agreements or representations, written or oral, concerning the subject matter of the EA.

**ACCEPTED AND AGREED:**

**IRVINE RANCH WATER DISTRICT  
(Customer)**

**ENVIRONMENTAL SYSTEMS RESEARCH  
INSTITUTE, INC.  
(Esri)**

Signature: \_\_\_\_\_

Signature: \_\_\_\_\_

Printed Name: \_\_\_\_\_

Printed Name: \_\_\_\_\_

Title: \_\_\_\_\_

Title: \_\_\_\_\_

Date: \_\_\_\_\_

Date: \_\_\_\_\_

**APPENDIX A**

**PRODUCTS AND DEPLOYMENT SCHEDULE**

**EA Products— Esri Flex (formerly Uncapped) \***

<b>Product - Perpetual</b>	<b>Total</b>
<b>ArcGIS Enterprise:</b> ArcGIS Enterprise (Advanced and Standard)	Esri Flex
<b>ArcGIS Enterprise Extensions:</b> ArcGIS 3D Analyst, ArcGIS Data Reviewer, ArcGIS Geostatistical Analyst, ArcGIS Network Analyst, ArcGIS Schematics, and ArcGIS Spatial Analyst	Esri Flex
<b>ArcGIS GIS Server:</b> Advanced, Standard, Basic	Esri Flex
<b>ArcGIS Enterprise Additional Capability Servers:</b> ArcGIS Image Server, ArcGIS GeoEvent Server	Esri Flex
<b>ArcGIS Monitor</b>	Esri Flex
<b>ArcGIS Runtime Advanced</b>	Esri Flex
<b>ArcGIS Runtime Analysis Extension</b>	Esri Flex

\*Esri Flex (formerly Uncapped) provides the right to Deploy quantities as needed throughout the term of the Agreement.

**EA Products—Capped Quantities**

<b>ArcGIS Perpetual Products</b>	<b>Rolled-In Qty.</b>	<b>Qty. to Be Deployed</b>	<b>Total</b>
ArcGIS Workflow Manager Server Advanced Up to Four Cores	0	1	1

<b>Annual Subscription Products</b>	<b>Year 1 May 23, 2026 – May 22, 2027</b>	<b>Year 2 May 23, 2027 – May 22, 2028</b>	<b>Year 3 May 23, 2028 – May 22, 2029</b>
ArcGIS Velocity Standard US Region Annual Subscription	1	1	1

<b>User Type Products</b>	<b>Year 1 May 23, 2026 – May 22, 2027</b>	<b>Year 2 May 23, 2027 – May 22, 2028</b>	<b>Year 3 May 23, 2028 – May 22, 2029</b>
<b>ArcGIS Enterprise</b>	<i>(number of Users per Term)</i>		
ArcGIS Enterprise Mobile Worker User Type Annual Subscription	10	20	30
ArcGIS Enterprise Creator User Type Annual Subscription	30	35	40

ArcGIS Enterprise Professional (formerly Standard) User Type Annual Subscription	8	8	8
ArcGIS Enterprise Professional Plus (formerly Advanced) User Type Annual Subscription	13	18	18
ArcGIS Advanced Editing User Type Extension for ArcGIS Enterprise Annual Subscription	20	20	20
ArcGIS 3D Analyst for ArcGIS Enterprise Creator or Professional User Type Annual Subscription	2	2	2
ArcGIS Network Analyst for ArcGIS Enterprise Creator or Professional User Type Annual Subscription	4	4	4
ArcGIS Spatial Analyst for ArcGIS Enterprise Creator or Professional User Type Annual Subscription	2	2	2
ArcGIS Image Analyst for ArcGIS Enterprise Creator or Professional User Type Annual Subscription	3	3	3
<b>ArcGIS Online (1 Organizational Subscription)</b>	<b>(total number of Users per Term)</b>		
ArcGIS Online Viewer User Type Annual Subscription	20	20	20
ArcGIS Online Mobile Worker User Type Annual Subscription (250 credits per user)	30	40	50
ArcGIS Online Creator User Type Annual Subscription (500 credits per user)	50	60	60
ArcGIS Online Professional (formerly Standard) User Type Annual Subscription (500 credits per user)	2	2	2
ArcGIS Online Professional Plus (formerly Advanced) User Type Annual Subscription (500 credits per user)	2	2	2
Additional Service Credits – Block of 1,000	16	8	6

**APPENDIX B**  
**EA FEE SCHEDULE**

	Year 1 May 23, 2026 - May 22, 2027	Year 2 May 23, 2027 - May 22, 2028	Year 3 May 23, 2028 - May 22, 2029	Total
Annual EA Fee	\$250,000	\$250,000	\$250,000	<b>\$750,000</b>

The EA also includes the following additional components:

Additional Benefits	Quantity
Esri International User Conference Registrations	12
Back-Up Media	2
Authorized Tier-Two Standard Support Callers	4

# Enterprise Agreement



## Enterprise Agreement No. 00315535.0

This Enterprise Agreement, including the documents listed below ("EA"), is between **Irvine Ranch Water District** ("**Customer**"), with its principal place of business at 15600 Sand Canyon Ave, Irvine, CA. 92618, and **Environmental Systems Research Institute, Inc.** ("**Esri**"), with an Effective Date as of the later date of the signatures below when signed by both. This EA provides for the licensing and Deployment of certain EA Products, delivery of EA Maintenance, and provision of Esri User Conference registrations and any additional services as specified herein.

This EA includes the following documents, which are incorporated herein by reference:

1. Enterprise Agreement signature page(s)
2. Enterprise License Terms and Conditions, including
  - Appendix A—Products and Deployment Schedule
  - Appendix B—EA Fee Schedule
  - Appendix C—EA Points of Contact
3. Master Agreement

The parties acknowledge that they have read and understand this EA and agree to be bound by the terms and conditions contained herein.

This EA constitutes the sole and entire agreement of the parties as to the subject matter set forth herein and supersedes any previous agreements, proposals, presentations, understandings, and arrangements between the parties relating to such subject matter. Any modifications or amendments to this EA must be in writing and signed by an authorized representative of each party.

ACCEPTED AND AGREED:

IRVINE RANCH WATER DISTRICT  
(Customer)

By:   
Authorized Signature

Printed Name: Paul Cook

Title: General Manager

Date: May 23, 2023

ENVIRONMENTAL SYSTEMS  
RESEARCH INSTITUTE, INC.  
(Esri)

By:   
Timothy Brazeal (May 11, 2023 16:28 PDT)  
Authorized Signature

Printed Name: Timothy Brazeal

Title: Manager, Commercial and Government Contracts

Date: May 11, 2023

## ENTERPRISE AGREEMENT TERMS AND CONDITIONS

### ARTICLE 1—DEFINITIONS

All definitions in other parts of the EA will have the same meaning in this Enterprise Agreement Terms and Conditions. In addition, the following definitions apply to the EA:

- "Case(s)" means a failure of Products to operate according to the Documentation where such failure substantially impacts operational or functional performance.
- "Customer(s)" means Irvine Ranch Water District. For avoidance of doubt, the definition of "Customer(s)" will not include consultants or contractors. Customer(s) must not include persons or entities ineligible to receive or have access to Esri products or services by operation of law, including US export control laws, decrees, orders, rules, regulations, policies, riders, conditions, or provisos.
- "Deploy," "Deployment," or "Deployed" means to redistribute, or the redistribution of, the EA Products (and their related keycodes/registration files), or their having been redistributed, by Customer during the term of this EA for installation and use by Customer.
- "EA Fee" means the fee set forth in Appendix B—EA Fee Schedule.
- "EA Maintenance" means Tier 2 Support, updates, and patches provided by Esri for EA Products and Rolled-In Software.
- "EA Products" means the Products identified in Tables A-1 and A-2 of Appendix A—Products and Deployment Schedule. EA Products do not include Unit-Priced Item(s) or Esri technology that may be embedded in third-party products purchased by Customer.
- "Effective Date" means the date the EA commences and the start date for all licenses, regardless of when an Ordering Document is provided by Customer.
- "Master Agreement" means the applicable master agreement incorporated by this reference that is either (i) the Click-Through Master Agreement, Products Only (E204CW) found at <https://www.esri.com/en-us/legal/terms/full-master-agreement> and available in the installation process requiring acceptance by electronic acknowledgment.
- "Rolled-In Software" means Products (excluding Term licenses or subscriptions) of the same type as EA Products that Customer acquired for use prior to the Effective Date, that are current on paid maintenance (as shown in Esri's customer service records), and that receive EA Maintenance during the term of the EA. If this EA is extended or renewed, Rolled-In Software shall include EA Products Deployed prior to the then-current renewal period.
- "Technical Support" means a process to attempt to resolve reported Case(s) through error correction, patches, hot fixes, and workarounds; replacement deliveries; or any other type of Product corrections or modifications specified in the most current applicable Esri Maintenance and Support Program.
- "Tier 1 Help Desk" means Customer's point of contact from which all Tier 1 Support will be given to Customer.
- "Tier 1 Support" means the Technical Support provided by the Tier 1 Help Desk as the primary contact to Customer in the attempted resolution of reported Case(s).
- "Tier 2 Support" means the Technical Support provided by Esri to the Tier 1 Help Desk when a Case cannot be resolved through Tier 1 Support.
- "Unit-Priced Item(s)" means separately orderable Products or maintenance that is available subject to a per-unit license fee, subscription fee, or maintenance fee.

### ARTICLE 2—GRANT OF LICENSE

**2.1 Grant of License.** During the term of this EA, Customer's use of the EA Products is subject to the Master Agreement and any additional terms set forth in this EA. Unit-Priced Items, if acquired, and Rolled-In Software will be licensed in accordance with the Master Agreement.

**2.2 Beta License.** Beta licenses are not available under this EA as EA Products.

### ARTICLE 3—SCOPE OF USE

During the term of this EA, the following terms supplement the Master Agreement for Customer's use of EA Products.

**3.1 Additional Permitted Uses.** For the term of the EA, Customer may copy and Deploy the EA Products to Customers up to the quantities of licenses granted in Appendix A. No other Customer has a right to copy (except as permitted in the Master Agreement) or Deploy the EA Products. Customer may transfer, redistribute, or Deploy the EA Products within the continental United States; Hawaii; Alaska; and US territories, excluding Puerto Rico and the US Virgin Islands.

### **3.2 Uses Not Permitted**

- a. Customer shall not use the EA Products outside the United States or its territories or possessions without the prior written permission of Esri and agreement on additional fees, if any. Any such export will be subject to US Export Control Regulation requirements of the Master Agreement.
- b. Customer shall not transfer, redistribute, or assign EA Products to any third party without the prior written permission of Esri.

**3.3 Consultant Access.** Customer's consultants or contractors may use EA Products in accordance with the Master Agreement. Customer may not permit its consultants or contractors to install EA Products on consultant, contractor, or third-party computers or remove EA Products from Customer locations except for the purposes of hosting the EA Products on contractor servers for the benefit of Customer.

## **ARTICLE 4—MAINTENANCE**

**4.1 EA Maintenance.** EA Maintenance is included in the EA Fee. Rolled-In Software and EA Products will receive EA Maintenance, provided that standard maintenance is available for each item. EA Maintenance includes benefits specified in the most current applicable Esri Maintenance and Support Program document (found at <https://www.esri.com/en-us/legal/terms/maintenance>) as modified by this Section 4.1.

### **a. Tier 1 Support Provided by Customer**

- (1) The Tier 1 Help Desk will provide Tier 1 Support to all Customers.
- (2) The Tier 1 Help Desk will use analysts fully trained in the Products they are supporting.
- (3) At a minimum, Tier 1 Support will include those activities that assist the user in resolving how-to and operational questions as well as questions on installation and troubleshooting procedures.
- (4) Tier 1 Support analysts will be the initial points of contact for all questions and Case(s). Tier 1 Support analysts shall obtain a full description of each reported Case and the system configuration from Customer. This may include obtaining any customizations, code samples, or data involved in the Case. The analyst may also use any other information and databases that may be developed to satisfactorily resolve Case(s).
- (5) If the Tier 1 Help Desk cannot resolve a Case, an authorized Tier 1 Help Desk individual may contact Esri for Tier 2 Support. The Tier 1 Help Desk shall provide support in such a way as to minimize repeat calls and make solutions available to Customer.
- (6) Customer may assign named Tier 1 Help Desk individuals up to the quantity listed in Appendix B. These individuals will be identified through the My Esri portal and will be the only individuals (callers) authorized to contact Esri directly for Tier 2 Support.

### **b. Tier 2 Support Provided by Esri**

- (1) Esri shall log the calls received from Tier 1 Help Desk individuals.
- (2) Esri shall review all information collected by and received from Tier 1 Help Desk individuals including preliminary documented troubleshooting provided by the Tier 1 Help Desk when Tier 2 Support is required.
- (3) Esri may request that Tier 1 Help Desk individuals provide verification of information, additional information, or answers to additional questions to supplement any preliminary information gathering or troubleshooting performed by Tier 1 Help Desk.
- (4) Esri shall attempt to resolve Case(s) submitted by Tier 1 Help Desk by assisting the Tier 1 Help Desk individuals and not Customer.

- (5) When a Case is resolved, Esri shall communicate the information to the Tier 1 Help Desk individuals, and the Tier 1 Help Desk shall disseminate the resolution to Customer.
- (6) Esri may, at its sole discretion, make patches, hot fixes, or updates available for downloading from Esri's website or, if requested, deliver them on media.

**4.2 Maintenance for Unit-Priced Items.** Annual maintenance fees for Unit-Priced Items are not included in the EA Fee, and if ordered, additional fees will apply.

## **ARTICLE 5—ORDERING, ADMINISTRATIVE PROCEDURES, DELIVERY, AND DEPLOYMENT REPORT**

### **5.1 Purchase Orders, Invoicing, Delivery, and Deployment**

- a. Esri does not require Customer to issue purchase orders and will invoice Customer for the initial payment upon the Effective Date of the EA. Subsequently, Esri may submit invoices up to thirty (30) days before (i) the payment date shown in Appendix B or, (ii) if no payment dates are shown, the anniversary dates of the EA. Customer may submit purchase orders in accordance with its own process requirements. If Customer issues purchase orders, then Customer will submit its initial purchase order upon execution of this EA and any subsequent purchase order at least thirty (30) days before the anniversary date. Invoices will be due and payable within thirty (30) days of invoice.
- b. Any purchase orders that Customer issues will reference, incorporate, and be subject to the terms and conditions of this EA. Additional or conflicting terms in any purchase orders, invoices, or other documents exchanged during the ordering process, other than the terms of this EA, Product or Service descriptions, quantities, pricing, and delivery instructions, are void and of no effect. Customer will process all orders and deliveries pertaining to this EA through Customer's centralized point of contact.
- c. Customer will include the following information in each purchase order:
  - (1) Esri customer number, the ship-to address, and bill-to address as identified in Appendix C.
  - (2) Purchase order number.
  - (3) Applicable annual payment due and name of Customer. For Unit-Priced Items, the name of the product and quantity.
  - (4) On the face of the purchase order, the following printed statement: "Governed by and subject to Enterprise Agreement No. 00315535.0."
- d. Esri will provide Authorization Codes to activate the nondestructive copy protection program that enables Customer to download, operate, or allow access to the EA Products listed in Appendix A.
- e. Delivery of updates/new versions of EA Products will be made in the same manner. If requested by Customer, Esri will deliver a limited number of sets of backup media as provided in Appendix B to the ship-to address identified in Appendix C—EA Points of Contact, FOB destination with shipping charges prepaid. Customer may purchase additional backup media sets at the prices in effect at the time of purchase. Delivery or receipt of tangible media could cause prior and future license fees to be subject to taxes. Esri may invoice for and Customer agrees to pay any such sales or use tax associated with receipt of tangible media.
- f. Esri reserves the right to suspend Customer's access to and use of EA Products if Customer fails to pay any undisputed amount owed on or before its due date. Esri may charge Customer interest at a monthly rate equal to the lesser of one percent (1.0%) per month or the maximum rate permitted by applicable law on any overdue fees plus all expenses of collection for any overdue balance that remains unpaid ten (10) days after Esri has notified Customer of the overdue balance.
- g. Certain Esri Offerings are consumption-based and allow Customer to sign up for payment in arrears; such consumption-based Esri Offerings will be billed separately and are not included in the EA Fees.

**5.2 Annual Report of Deployments.** At each anniversary date and ninety (90) days prior to the expiration date of this EA, Customer shall provide Esri a written report, in the form provided by Esri, detailing all Deployments made, including preexisting and Rolled-In Software (each a "Deployment Report"). The report will be subject to audit by an authorized representative of Esri.

**5.3 Esri User Conference Registration.** Esri shall provide Esri User Conference registrations to Customer annually during the term of this EA in the quantities set forth in Appendix B. Customer is responsible for

distributing the registrations to Customers. Third parties may not represent or attend on behalf of Customer at any Esri User Conference.

## ARTICLE 6—POINTS OF CONTACT; NOTICES

**6.1 Points of Contact.** In Appendix C, each party shall identify points of contact for administrative and technical issues.

**6.2 Legal Notices.** Except as otherwise set forth in this EA, any notice, report, demand, or other communication will be made in writing in English; sent by courier, registered or certified airmail, or facsimile or other electronic transmission; and confirmed when sent by courier or by registered or certified airmail, properly addressed to the appropriate party at the address set forth below, until changed by notice in writing by either party hereto. If sent by courier or airmail, notice will be effective upon the earlier of confirmed receipt or seven (7) days from the date of deposit with the courier service or post office. If sent by electronic transmission, notice will be effective one (1) business day from the date of transmission, provided confirmation of receipt is made. Notices will be given at the following addresses:

To: Esri  
380 New York Street  
Redlands, CA 92373-8100  
Attn.: Director of Contracts and Legal  
Fax: 909-307-3020  
Email: [legalnotices@esri.com](mailto:legalnotices@esri.com)

To: Customer  
as listed in Appendix C

## ARTICLE 7—TERM, TERMINATION, AND EXPIRATION

**7.1 Term.** The term of the EA will commence on the Effective Date and be for the period listed in Appendix B unless this EA is terminated earlier as provided herein.

**7.2 Termination for a Material Breach; Convenience.** Esri may terminate this EA for a material breach by Customer. Customer will be given a period of thirty (30) days from date of written notice to cure any material breach. Upon termination of this EA by Esri for a material breach by Customer, all licenses Deployed will also terminate, and the full amount of unpaid EA Fees will be due and payable by Customer within thirty (30) days from the date of termination. Customers shall uninstall, remove, and destroy all EA Products; training materials; and any whole or partial copies, modifications, or merged portions in any form. Customer shall deliver evidence of such destruction to Esri (e.g., certification letter). Customer may continue to use Rolled-In Software, provided Customer complies with the terms and conditions of the Master Agreement. Further, Esri agrees that Customer is not required to pay a maintenance reinstatement fee for lapsed maintenance for Rolled-In Software if Customer orders maintenance at time of EA termination. Other items that may be included in this EA—such as Advantage Program, access codes, and Esri User Conference registrations—will also terminate if this EA is terminated. This EA may not be terminated for convenience.

### 7.3 Reserved

**7.4 License Term and Use upon Expiration of EA Term.** Upon full payment of EA Fee and expiration of this EA, the Master Agreement will survive, and Customer may continue to use the Deployed EA Products included in the final Deployment Report and Rolled-In Software in accordance with the terms and conditions set forth in the Master Agreement. Customer shall notify Esri of the quantity and type of licenses for which Customer elects to purchase standard maintenance. If maintenance is not ordered for Rolled-In Software or EA Products upon expiration of the EA, it lapses. If, at a later date, Customer decides to reinstate maintenance, Customer must pay maintenance reinstatement fees from the date of EA expiration (i.e., back maintenance fees). Customer may only purchase standard maintenance or reinstate maintenance on licenses that were included in the final Deployment Report. Customer shall not Deploy additional copies of the EA Products beyond the quantities in use upon termination or as of the date of expiration.

**7.5 Termination for Non-Appropriation of Funds or Lack of Funds.** Customer's obligation to pay the amounts due under this EA may be contingent upon appropriation of funds for this EA ("**Lack of Funds**"). Either party may terminate this EA for Lack of Funds by providing a written termination for Lack of Funds notice no less than sixty (60) days prior to the next annual EA payment. In all such cases, the effective date of the termination will be the last day of the EA year for which Customer has paid. Under no circumstances may Customer deploy additional copies of the EA Products upon termination of the EA for Lack of Funds.

- a. Customer may retain a combination of some or all of the perpetual Deployed EA Products and all Rolled-In Software of like products identified in Appendix A, subject to the following conditions:
  - i. Customer will report the quantity and types of EA Products Deployed as of the termination date;
  - ii. Esri will calculate the aggregate value of EA Products Deployed, excluding Online Services or term based Products, at then-current list price, plus the aggregate cost of maintenance for the Deployed EA Products and Rolled-In Software (collectively, the "**Deployed EA Value**");
  - iii. Esri will deduct the value of all other deliverables, including but not limited to Online Services, term based Products training, virtual campus, workshops, and services, provided as part of this EA from the total EA Fees paid by Customer, as set forth on Appendix B, at the date of termination, ("**Remaining Value**");
  - iv. If the Deployed EA Value is less than or equal to the Remaining Value, Customer may retain all Deployed perpetual EA Products and Rolled-In Software at the maintenance version current as of the date of termination. No refund will be provided to Customer for unused fees.
  - v. If the Deployed EA Value is greater than the Remaining Value, Customer will inform Esri of the quantities of Deployed EA Products and Rolled-in Software that it will retain at the maintenance version current as of the date of termination, such that the aggregate Software and maintenance does not exceed the Remaining Value. Customer will uninstall, remove and destroy all Deployed EA Products not retained. Rolled-In Software not retained at current maintenance will revert to the version that was current as of the start date of the EA term.
- b. After termination, Customer must immediately uninstall, remove and destroy all Deployed EA Products not retained. All subscriptions, User Conference Passes, Training and other services will end at termination. Rolled-In software not retained at current maintenance will revert to the version that was current as of the start date of the EA term.
- c. Within thirty (30) days of termination of the EA for Lack of Funds, Customer will document in writing to Esri the total quantity and type of Products for which Customer desires to obtain maintenance, if any. Payment of maintenance fees will be effective from the date of the EA termination.
- d. Customer's use of any retained Products and Rolled-In Software following termination of the EA Agreement will be in accordance with the License Agreement. If at a future date Customer chooses to renew its Rolled-In Software or any other retained Products, Customer will be required to pay maintenance retroactive to the date of termination in order to receive the most current version and support.

## **ARTICLE 8—CONFIDENTIALITY**

**8.1 Esri Confidential Information.** Subject to the State of California Records Act or similar regulations enacted by Customer, certain terms and conditions of this EA are confidential and proprietary information of Esri. Except as provided herein (e.g. the State of California Records Act or similar regulations enacted by Customer), Customer shall not publish or disclose the EA (or contents) to any third party without Esri's prior written consent. Disclosure may be made only to those Customer employees, contractors, or consultants of Customer (e.g., outside counsel or accountants) who have a need to know to perform their duties or work on behalf of Customer and have an obligation of confidentiality. No other portions of the EA may be disclosed to a contractor or consultant.

**8.2 Disclosure of Fees for Unit-Priced Item(s).** If Unit-Priced Items are included in this EA, Esri gives permission to Customer to maintain Unit-Priced Item prices, fees, and discounts on Customer's intranet, subject to password protection accessible to Customers, to support potential procurements. Customer shall use no less than the same degree of care to protect this information as it uses to protect its own confidential information or

third-party information of similar nature. Customer must include the following notice on information concerning this EA and its pricing posted on or accessible through Customer intranet that is accessible by Customers and their employees, or on any other web pages that make reference to this EA, including order forms:

**PRICING INFORMATION, INCLUDING APPLICABLE DISCOUNT RATES, CONTAINED HEREIN IS CONSIDERED CONFIDENTIAL AND PROPRIETARY. EXCEPT TO SUPPORT AUTHORIZED LICENSE ACQUISITIONS, RECIPIENT WILL NOT COPY, DISCLOSE TO ANY THIRD PARTY, OR USE ANY PRICING INFORMATION FOR ANY OTHER PURPOSE OR PROGRAM.**

#### **ARTICLE 9—RELATIONSHIP OF THE PARTIES**

The EA does not constitute a partnership, joint venture, or agency between Esri and Customer. Neither Esri nor Customer will hold itself out as such, nor shall Esri or Customer be bound or become liable because of any representation, action, or omission of the other.

#### **ARTICLE 10—FORCE MAJEURE**

If the performance of any obligation under this EA is prevented, restricted, or interfered with by reason of fire, flood, earthquake, explosion, or other casualty or accident; strikes or labor disputes; inability to procure or obtain delivery of parts, supplies, or power; war; threat of or actual terrorist act, cyber attack, or other violence; any law, order, proclamation, regulation, ordinance, demand, or requirement of any government agency; or any act or condition whatsoever beyond the reasonable control of the affected party, the party so affected, upon giving prompt notice to the other party, will be provided a temporary extension for a period of time as may be reasonably necessary to allow for such delay, prevention, interference, or restriction.

#### **ARTICLE 11—GIS STANDARD**

Customer shall officially name Esri as its GIS standard and act as a reference for other Esri customers and potential customers as long as the EA remains in effect. This EA will not be construed or interpreted as an exclusive dealings agreement, and Customer reserves the right to purchase from third parties any of their requirements for GIS software or related services.

Customer agrees that Esri may publicize the existence of the EA.

#### **ARTICLE 12—ADMINISTRATIVE REQUIREMENTS**

**12.1 Esri Partner Original Equipment Manufacturer (OEM) Bundled or Embedded Items/Services.** Certain Esri partners are authorized to either embed limited portions of Esri technology or bundle Esri products or services with the partner's application or service under Esri's OEM or Solution OEM programs. Partner pricing and product bundling is independent of this EA, and each partner markets under its own business model and pricing. Customer shall not be entitled to or seek any discount from the OEM partner or Esri, directly or indirectly, as a result of or based on the availability of such Products as EA Products under this EA. Customer shall not be entitled to or seek to decouple Esri's technology or products/services from the partner's bundle or solution. In addition, such Products, or any component thereof included in the OEM software program or product, will be licensed through the license agreement provided by the OEM partner and not through this EA.

**12.2 EA Products—Limited Quantity or Unit-Priced Items.** Esri reserves the right to exclude new Products from uncapped Deployment. New Products may contain or be developed with (i) newly acquired technology obtained through a significant investment or (ii) third-party intellectual property that requires a unit-based royalty fee or prohibits Deployment under a site or enterprise license. Such items can be made available to Customer on a limited-quantity basis or as unit-priced items.

**12.3 Obsolescence.** During the term of this EA, some of the items listed in Appendix A may become obsolete, will no longer be commercially offered, or may no longer be available for Deployment. Customer may continue to use EA Products that have been Deployed, but support and upgrades for older items may not be available. EA Maintenance and maintenance and availability of EA Products identified in Appendix A will be subject to each item's Product Life Cycle Support Status and Esri's Product Life Cycle Support Policy, which can be found at

<https://support.esri.com/en/other-resources/product-life-cycle> by selecting the product type and clicking the Product Life Cycle link for specific product plans.

**12.4 Mergers, Acquisitions, Asset Purchases, or Divestitures.** Customer may not transfer or Deploy EA Products to any third party in connection with a divestiture, merger, or sale of Customer or its assets, in whole or in part.

#### **ARTICLE 13—GENERAL PROVISIONS**

**13.1** If there is a conflict among any of the terms and conditions in the various documents, the order of descending precedence will be as follows: (1) Signature Page, (2) Enterprise License Terms and Conditions, (3) Master Agreement. For the avoidance of doubt, Article 7—Term, Termination, and Expiration of this EA supersedes any termination language in the Master Agreement with respect to all Products and Services provided under this EA. If Customer subscribes to the Advantage Program, the Advantage Program terms and conditions take precedence over the provisions of this EA with respect to products or services provided under Advantage Program. Except as otherwise expressly provided herein, any amendment or addendum to this EA must be in writing and signed by an authorized representative of each party.

**13.2 Survival of Certain EA Clauses.** The provisions of Sections 2.3 and 7.4 and Article 8 of this Enterprise License Terms and Conditions document will survive the expiration or termination of this EA.

**APPENDIX A  
PRODUCTS AND DEPLOYMENT SCHEDULE**

Customer may Deploy the EA Products up to the total quantity of licenses indicated below to Customers during the term of this EA.

**Table A-1  
EA Products—Uncapped Quantities**

<b>Product</b>	<b>Total</b>
<b>ArcGIS Desktop:</b> Advanced, Standard, and Basic (Single and Concurrent Use)	Uncapped
<b>ArcGIS Desktop Extensions:</b> ArcGIS 3D Analyst, ArcGIS Data Reviewer, ArcGIS Geostatistical Analyst, ArcGIS Network Analyst, ArcGIS Publisher, ArcGIS Schematics, ArcGIS Spatial Analyst, and ArcGIS Workflow Manager (Single and Concurrent Use)	Uncapped
<b>ArcGIS Enterprise:</b> ArcGIS Enterprise (Advanced and Standard)	Uncapped
<b>ArcGIS Enterprise Extensions:</b> ArcGIS 3D Analyst, ArcGIS Geostatistical Analyst, ArcGIS Network Analyst, ArcGIS Schematics, ArcGIS Spatial Analyst, and ArcGIS Workflow Manager	Uncapped
<b>ArcGIS GIS Server:</b> Advanced, Standard, Basic	Uncapped
<b>ArcGIS Enterprise Additional Capability Servers:</b> ArcGIS Image Server, ArcGIS GeoEvent Server	Uncapped
<b>ArcGIS Monitor</b>	Uncapped
<b>ArcGIS Runtime Advanced</b>	Uncapped
<b>ArcGIS Runtime Analysis Extension</b>	Uncapped
<b>Mapping and Charting Solutions:</b> Esri Production Mapping for Desktop (Single and Concurrent Use)	Uncapped

**Table A-2  
EA Products—Capped Quantities**

<b>User Type Product</b>	<b>Term 1</b>	<b>Term 2</b>	<b>Term 3</b>
<b>ArcGIS Enterprise (Total Users)</b>			
ArcGIS Enterprise Mobile Worker Annual Subscription	50	50	50
ArcGIS Enterprise Creator Annual Subscription	10	10	10
ArcGIS Utility Network Service User Type Extension for ArcGIS Enterprise Term License	20	20	20
ArcGIS Insights in ArcGIS Enterprise Annual Subscription	1	1	1
<b>ArcGIS Online (Total Users)</b>			
ArcGIS Online Creator Annual Subscription (500 credits per user)	20	20	20
<b>Developer Premium annual subscription</b>	1	1	1
<b>StreetMap Premium Desktop US Full Use Desktop SU version</b>	1	1	1
<b>ArcGIS StreetMap Premium for Runtime Deployments USA term license</b>	20	20	20

**APPENDIX B  
EA FEE SCHEDULE**

The EA Fee is \$480,000. The EA Fee is in consideration of the EA Products, EA Maintenance, and Esri User Conference registrations.

	<b>Term 1</b>	<b>Term 2</b>	<b>Term 3</b>	<b>EA Fee</b>
<b>Payments</b>	<b>\$160,000</b>	<b>\$160,000</b>	<b>\$160,000</b>	<b>\$480,000</b>

<b>Number of Esri User Conference Registrations per Year</b>	<b>7</b>
<b>Number of Tier 1 Help Desk Callers That May Contact Esri for Tier 2 Support</b>	<b>3</b>
<b>Number of Sets of Backup Media, if Requested</b>	<b>2</b>
<b>Term of EA</b>	<b>Three years from Effective Date</b>

**(Optional)  
Unit-Priced Items**

Licenses and Maintenance for Unit-Priced Items are available at the prices set forth below and are not included in the EA Fee. Pricing is valid for one (1) year from the Effective Date and may be updated by Esri by written notice to Customer. Unit-Priced Items will be licensed in accordance with the terms and conditions of the Master Agreement.

<b>Item</b>	<b>License Price</b>	<b>Maint. Price</b>
None		

**APPENDIX C  
EA POINTS OF CONTACT**

Either party may change its point of contact by written notice to the other party.

1. Esri point of contact for order processing issues:

Name: Customer Service  
Esri  
380 New York Street  
Redlands, CA 92373-8100  
Email: [service@esri.com](mailto:service@esri.com)  
Phone: 888-377-4575  
Fax: 909-307-3083

2. Esri contact for Tier 2 Support issues:

MyEsri: <https://my.esri.com>  
Phone: 909-793-3774 (within the United States only)  
Web: <https://support.esri.com>

3. Customer centralized point of contact for order release and administrative issues:

Name: Lance Kaneshiro  
Email: Kaneshiro@irwd.com  
Phone: 949-453-5480  
Fax: \_\_\_\_\_

4. All invoices to Customer will be mailed to the address listed below:

Customer Office: Lance Kaneshiro Information Services  
Name: Lance Kaneshiro  
Address: 15600 Sand Canyon Ave  
Irvine, CA 92619

5. All deliverables to Customer will be shipped to the address listed below:

Customer Office: Information Services  
Name: Lance Kaneshiro  
Address: 15600 Sand Canyon Ave  
Irvine, CA 92619

6. All notices to Customer will be mailed to the address listed below:

Customer Office: Information Services  
Name: Lance Kaneshiro  
Address: 15600 Sand Canyon Ave  
Irvine, CA 92619





# Irvine Ranch Water District / EA

Final Audit Report

2023-05-11

Created:	2023-05-11
By:	Joe Collins (jcollins@esri.com)
Status:	Signed
Transaction ID:	CBJCHBCAABAAAgV3iNxiw1QXmRyi6Tqt07_JEieS29z

## "Irvine Ranch Water District / EA" History

-  Document created by Joe Collins (jcollins@esri.com)  
2023-05-11 - 11:10:12 PM GMT- IP address: 13.110.74.8
-  Document emailed to Timothy Brazeal (Tbrazeal@esri.com) for signature  
2023-05-11 - 11:11:03 PM GMT
-  Email viewed by Timothy Brazeal (Tbrazeal@esri.com)  
2023-05-11 - 11:27:45 PM GMT- IP address: 104.47.51.126
-  Document e-signed by Timothy Brazeal (Tbrazeal@esri.com)  
Signature Date: 2023-05-11 - 11:28:07 PM GMT - Time Source: server- IP address: 76.175.87.7
-  Agreement completed.  
2023-05-11 - 11:28:07 PM GMT

Note: This page is intentionally left blank.

May 26, 2026  
Prepared and  
submitted by: C. Compton  
Approved by: Paul A. Cook 

## CONSENT CALENDAR

### RESOLUTION AUTHORIZING INITIATION OF AN ORANGE COUNTY LOCAL AGENCY FORMATION COMMISSION PROCEEDING FOR THE ANNEXATION OF THE LOS ALISOS WATER RECYCLING PLANT AREA INTO THE ORANGE COUNTY SANITATION DISTRICT

#### SUMMARY:

The majority of IRWD’s service area is located within the Orange County Sanitation District (OC San) jurisdictional boundary. The portion of IRWD’s service area consisting of the former Los Alisos Water District (LAWRP Area) is currently outside of OC San’s jurisdictional boundary and sphere of influence. On December 1, 2025, IRWD and OC San entered into the “Flow Exchange Agreement,” which, among other things, calls for IRWD and OC San to seek annexation of the LAWRP Area into the OC San jurisdictional boundary. This annexation will not change how IRWD’s customers received their sewer services; it will allow for sewage that originated from this area to flow into the OC San system in the future.

Staff recommends that the Board adopt a resolution authorizing initiation of an Orange County Local Agency Formation Commission (OC LAFCO) proceeding for the annexation of the IRWD’s LAWRP Area into OC San’s jurisdictional boundary consistent with the Flow Exchange Agreement.

#### BACKGROUND:

The Flow Exchange Agreement between IRWD and OC San, executed on December 1, 2025, consolidated and simplified several prior agreements related to the Harvard Area Trunk Sewer (HATS), Irvine Business Complex (IBC), Jamboree / Bison area, San Joaquin Hills Planned Community, Orange Park Acres, and U.S. Food and Drug Administration Property. It also established a pathway for IRWD’s LAWRP Area to be annexed into OC San’s jurisdictional boundary. A map of the area is provided as Exhibit “A”.

While IRWD does not send or intend to send sewage from the LAWRP Area to OC San facilities at this time, annexation of the area into OC San’s boundary would allow for that capability in the future because IRWD is prohibited from bringing sewage into the OC San’s service area that may reach OC San’s facilities, directly or indirectly, from outside of the OC San service area. Because flow from the LAWRP Area could go to Michelson Water Recycling Plant, the Flow Exchange Agreement calls for IRWD to OC San to pursue annexation of the LAWRP Area into OC San’s jurisdictional boundaries. The agreement also calls on both agencies to file joint resolutions with LAFCO to initiate the annexation proceeding. This requested annexation will not change how IRWD provides sewer service to its existing and future customers in the LAWRP area. IRWD customers in the LAWRP Area, who are currently subject to the pre-treatment ordinance of the South Orange County Wastewater Authority (SOCWA), will also be subject to OC San’s Pre-Treatment Ordinance – whichever is the more stringent standard.

A resolution authorizing the initiation of annexation proceeding is attached as Exhibit “B”. The OC San Board of Directors will be considering a similar resolution at its May 27, 2026, Board meeting. Both resolutions, if adopted, would be included in the application to OC LAFCO for the annexation.

FISCAL IMPACT:

The fiscal impact, beyond those already contemplated in the Flow Exchange Agreement, are the District’s costs for OC LAFCO to process the annexation. Those expenses can be accounted for within the approved operating budget.

ENVIRONMENTAL COMPLIANCE:

Not applicable.

COMMITTEE STATUS:

This item was not reviewed by a Committee.

RECOMMENDATION:

That the Board adopt the following resolution by title:

RESOLUTION NO. 2026 – 4

RESOLUTION OF THE BOARD OF DIRECTORS OF THE  
IRVINE RANCH WATER DISTRICT  
AUTHORIZING INITIATION OF PROCEEDINGS AND REQUESTING THE  
ORANGE COUNTY LOCAL AGENCY FORMATION COMMISSION  
TO UNDERTAKE PROCEEDINGS FOR THE ANNEXATION OF THE  
LOS ALISOS AREA INTO THE ORANGE COUNTY SANITATION DISTRICT

LIST OF EXHIBITS:

Exhibit “A” – Map of the LAW RP Annexation Area  
Exhibit “B” – Resolution Authorizing Initiation of Annexation Proceedings



OC SAN

# Exhibit "A" - Transfer and Annexation Areas

May 2026

CARLSON/PARK & SAN MARCO APTS

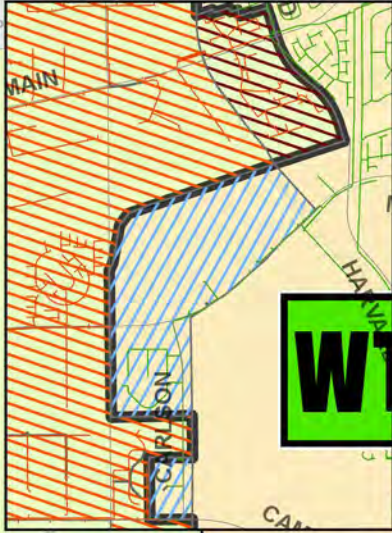

### LEGEND

- WTP** Treatment Plants
- OC San Consolidated Area
- Revenue Area 14 after Flow Exchange Agreement
- IRWD Boundary
- ETWD
- Flow from SMWD to IRWD

### TRUNK TRIBUTARY TREATMENT

- BY IRWD
- BY OCSD
- BY SMWD (to Chiquita treatment plant)

### AREAS

- LAWRP Area Annexation
- IRWD to OC San Transfer Area
- IRWD to OC San Update
- IBC Service Area to Remain in IRWD
- OC San to IRWD Transfer Area

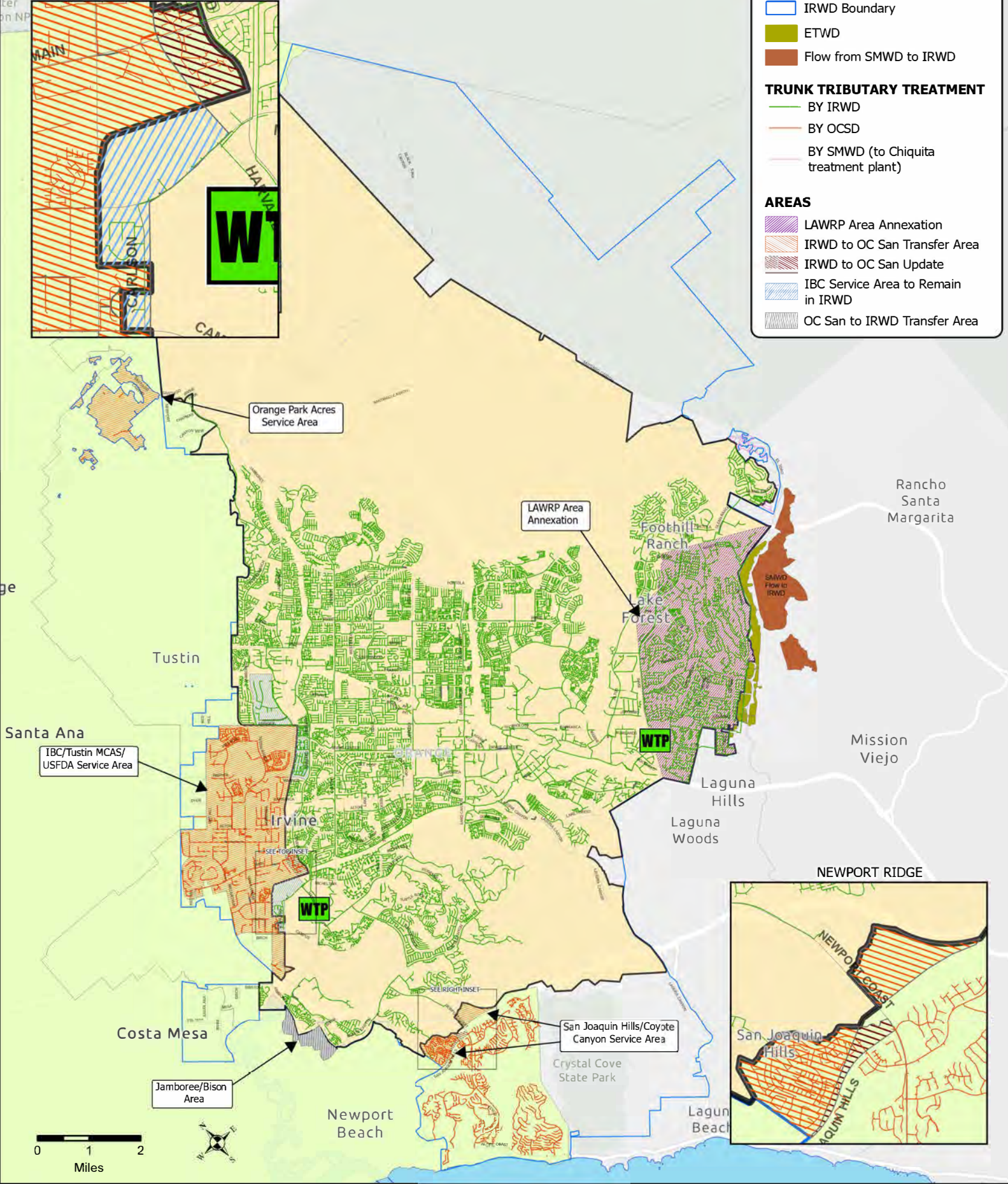

Orange Park Acres Service Area

LAWRP Area Annexation

Foothill Ranch

Lake Forest

WTP

Tustin

Rancho Santa Margarita

Mission Viejo

Santa Ana

IBC/Tustin MCAS/USFDA Service Area

Irvine

Laguna Hills

Laguna Woods

NEWPORT RIDGE



Costa Mesa

San Joaquin Hills/Coyote Canyon Service Area

Crystal Cove State Park

Jamboree/Bison Area

Newport Beach

Laguna Beach



Note: This page is intentionally left blank.

Exhibit “B”

RESOLUTION NO. 2026 – 4

RESOLUTION OF THE BOARD OF DIRECTORS OF THE  
IRVINE RANCH WATER DISTRICT  
AUTHORIZING INITIATION OF PROCEEDINGS AND REQUESTING THE ORANGE  
COUNTY LOCAL AGENCY FORMATION COMMISSION TO UNDERTAKE  
PROCEEDINGS FOR THE ANNEXATION OF  
THE LOS ALISOS WATER RECYCLING PLANT AREA TO  
THE ORANGE COUNTY SANITATION DISTRICT

Irvine Ranch Water District (“IRWD”) is organized and exists pursuant to the California Water District Law, California Water Code Section 34000 *et seq.* IRWD owns, operates, and maintains sewage collection, treatment, recycling, and disposal facilities including the Los Alisos Water Recycling Plant (“LAWRP”), and provides sewage services in portions of Orange County including the service area of the former Los Alisos Water District, which was consolidated with IRWD on December 31, 2000 (“Los Alisos Area” or “LAWRP Area”).

The Orange County Sanitation District (“OC San”) is a duly organized County Sanitation District, existing pursuant to the County Sanitation District Act (California Health & Safety Code Section 4700 *et seq.*). OC San owns, operates, and maintains sewage collection, treatment, and disposal facilities.

While the majority of IRWD’s service area is within OC San’s jurisdictional boundary, the LAWRP Area is outside of OC San’s jurisdictional boundary and sphere of influence. The LAWRP Area, is depicted in Attachment “A”, provided hereto and incorporated herein by this reference.

IRWD is currently prohibited from bringing sewage from the LAWRP Area into OC San’s service area that may reach OC San’s facilities, directly or indirectly, because the LAWRP Area is currently outside of the OC San service area.

While IRWD does not send or intend to send sewage, treated sewage, or solids from the LAWRP Area to OC San facilities at this time, IRWD may do this in the future. To allow for that capability in the future, OC San and IRWD have agreed to seek annexation of the LAWRP Area into OC San’s jurisdictional boundary.

THE BOARD OF DIRECTORS OF THE IRVINE RANCH WATER DISTRICT  
THEREFORE RESOLVES AS FOLLOWS:

Section 1: IRWD is hereby authorized to initiate and requests the Orange County Local Agency Formation Commission to undertake proceedings to expand OC San’s Service Area to include the above referenced LAWRP Area.

ADOPTED, SIGNED, and APPROVED on May 26, 2026.

---

President  
IRVINE RANCH WATER DISTRICT

---

Secretary  
IRVINE RANCH WATER DISTRICT

APPROVED AS TO FORM:  
HANSON BRIDGETT LLP

By: \_\_\_\_\_  
General Counsel

Attachment "A"

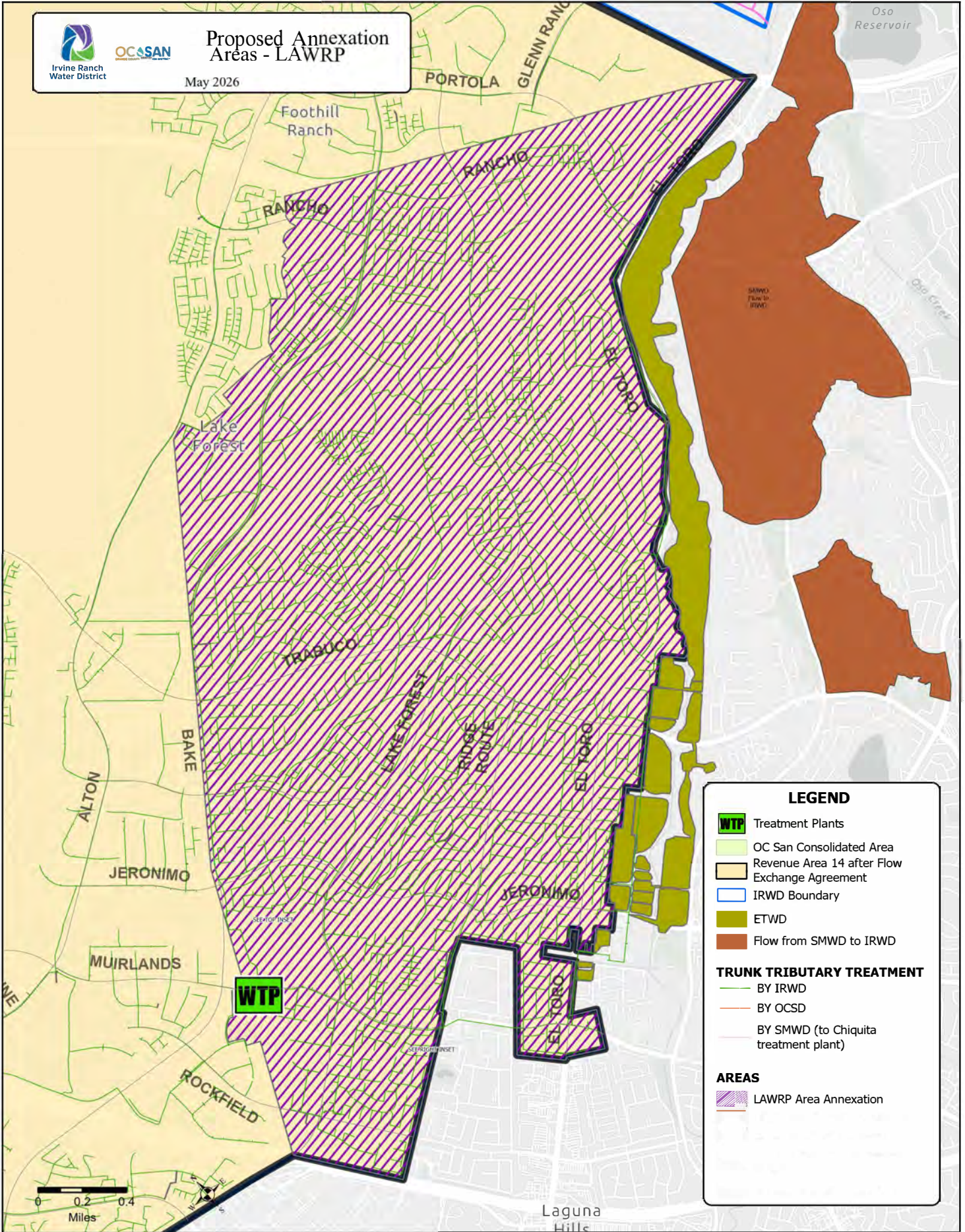

Note: This page is intentionally left blank.

May 26, 2026

Prepared by: M. Alvarez / B. Waite

Submitted by: K. Burton

Approved by: Paul A. Cook 

## ACTION CALENDAR

### EAST IRVINE ZONE 3-4 PUMP STATION REHABILITATION CONSULTANT SELECTION AND BUDGET ADJUSTMENT

#### SUMMARY:

IRWD is undertaking the East Irvine Zone 3-4 Pump Station Rehabilitation project to address aging, unreliable, and obsolete mechanical, electrical, and controls infrastructure at this critical facility. The project will improve long-term reliability and maintainability by increasing the useful life of this pump station.

Staff recommends that the Board:

- Authorize a budget increase for Project 12565 in the amount of \$3,780,000, from \$2,500,000 to \$6,280,000; and
- Authorize the General Manager to approve a Professional Services Agreement with Jacobs in the amount of \$938,942 for engineering design services for the East Irvine Zone 3-4 Pump Station Rehabilitation.

#### BACKGROUND:

The East Irvine Zone 3 to 4 Pump Station is an above-grade, outdoor, domestic water pump station located on Alton Parkway in the City of Irvine. The station conveys water from the adjacent Zone 3 Reservoirs to the Zone 4 system and plays a critical role in maintaining reliable water service.

The facility's mechanical, electrical, and control systems are over 35 years old and have experienced ongoing operational challenges. These issues have contributed to reduced reliability and premature failure of the pumps resulting in no pumping redundancy. Currently, only two of the four pumps are in service with one of the pumps undergoing rehabilitation. Overall, the station's equipment has reached or exceeded its expected service life and has continued to degrade due to long-term exposure to outdoor conditions.

This project will evaluate options to rehabilitate or replace aging equipment to improve system reliability and performance. Mechanical pumps and electrical and control systems are anticipated to be replaced while associated mechanical piping, surge tank, and appurtenances will be evaluated through a condition assessment to determine the appropriate level of rehabilitation or replacement. The project will also evaluate site security improvements to enhance safety and reduce the potential for break-ins. A key priority for this project will be minimizing service disruptions during construction through careful planning, temporary power provisions, and coordination with staff and Southern California Edison. The selected consultant will prepare bid-ready construction documents along with a supporting construction cost estimate and schedule in accordance with District standards.

Consultant Selection Process:

IRWD issued a Request for Proposals for engineering design services to five design firms: Brown and Caldwell, HDR, Jacobs, MKN, and WHB Engineers. Proposals were received from Brown and Caldwell, HDR, Jacobs, and WHB Engineers. The remaining firm declined to submit a proposal citing workload and schedule constraints.

Staff evaluated the proposals received and determined that Jacobs submitted the best proposal by addressing the project objectives. Jacobs proposed a highly qualified and experienced team with all core team members located in its Irvine office. Jacobs' project understanding and approach included a well-defined construction sequencing plan, demonstrating a strong understanding of IRWD's operational constraints, and need to minimize outages. Jacobs demonstrated a thorough understanding of the scope of work, supported by an appropriate list of drawings and specifications, and a reasonable level of effort for each task. The consultant selection matrix is attached as Exhibit "A", and Jacobs' scope of work and fee proposal are provided as Exhibit "B".

Staff recommends that the Board authorize the General Manager to execute a Professional Services Agreement with Jacobs in the amount of \$938,942 for engineering design services for the East Irvine Zone 3-4 Pump Station project.

FISCAL IMPACTS:

Project 12565 is currently in the FY 2025-26 Capital Budget. This project is funded 100% from the Domestic Water Replacement Fund. A budget increase is required to fund the design and construction phases as shown in the table below:

Project No.	Current Budget	Addition <Reduction>	Total Budget
12565	\$ 2,500,000	\$ 3,780,000	\$ 6,280,000

ENVIRONMENTAL COMPLIANCE:

This project is subject to the California Environmental Quality Act (CEQA). In conformance with the California Code of Regulations Title 14, Chapter 3, Section 15004, the appropriate environmental document will be prepared when "meaningful information" becomes available.

COMMITTEE STATUS:

This item was reviewed by the Engineering and Operations Committee on May 19, 2026.

RECOMMENDATION:

THAT THE BOARD AUTHORIZE A BUDGET INCREASE IN THE AMOUNT OF \$3,780,000, FROM \$2,500,000 TO \$6,280,000, AND AUTHORIZE THE GENERAL MANAGER TO EXECUTE A PROFESSIONAL SERVICES AGREEMENT WITH JACOBS IN THE AMOUNT OF \$938,942 FOR ENGINEERING DESIGN SERVICES FOR THE EAST IRVINE ZONE 3-4 PUMP STATION REHABILITATION, PROJECT 12565.

Action Calendar: East Irvine Zone 3-4 Pump Station Consultant Selection

May 26, 2026

Page 3

LIST OF EXHIBITS:

Exhibit "A" – Consultant Selection Matrix

Exhibit "B" – Scope of Work and Fee Proposal

Note: This page is intentionally left blank.

Exhibit "A"

CONSULTANT SELECTION MATRIX

East Irvine Zone 3-4 PS Rehab										
Item	Description	Weights	Brown and Caldwell		HDR		Jacobs		WHB Engineers	
A	<b>TECHNICAL APPROACH</b>									
1	Project Understanding and Approach	25%	2		3		1		4	
2	Related Project Experience	20%	3		2		1		4	
3	Project Team and Staff Qualifications	20%	3		2		1		4	
4	Scope of Work	25%	3		2		1		3	
5	History of Performance	10%	2		1		3		4	
	<u>Weighted Score</u>		2.7		2.2		1.2		3.8	
	<b>Ranking of Consultants</b>		3		2		1		4	
B	<b>SCOPE OF WORK</b>									
TASK	DESCRIPTION		Task Hours	Fee	Task Hours	Fee	Task Hours	Fee	Task Hours	Fee
1	<b>Project Management</b>		617	<b>\$159,478</b>	422	<b>\$128,300</b>	333	<b>\$91,577</b>	356	<b>\$95,506</b>
2	<b>Preliminary Design</b>		1,318	<b>\$312,244</b>	800	<b>\$239,600</b>	1,554	<b>\$351,511</b>	1,113	<b>\$258,046</b>
3	<b>Final Design</b>		2,195	<b>\$496,930</b>	2,425	<b>\$551,700</b>	2,034	<b>\$424,719</b>	1,286	<b>\$292,926</b>
4	<b>Bid Support</b>		82	<b>\$18,395</b>	142	<b>\$38,100</b>	102	<b>\$28,762</b>	120	<b>\$27,824</b>
	<b>TOTAL ENGINEERING SERVICES FEE</b>		4,212	<b>\$987,047</b>	3,789	<b>\$957,700</b>	4,161	<b>\$938,942</b>	3,086	<b>\$744,284</b>
C	<b>OTHER</b>									
	<b>Technical Drawings</b>									
	Total Sheets		56	dwgs	65	dwgs	40	dwgs	46	dwgs
	<b>Personnel</b>									
	<b>Role</b>		<b>Years of Experience</b>		<b>Years of Experience</b>		<b>Years of Experience</b>		<b>Years of Experience</b>	
	Project Manager		Kirstin Byrne Kale	15	Todd Engstrand	31	Marielle Coquia	30	Luis Soto	18
	Design Manager/Project Engineer		Ryan Mangosong	8	Curtis Gauthier	12	Deanie Ding	26	Justin Todd	12
	Electrical		Sang V. Vo	19	Andrew Tee	11	Adam Nichols	22	Long Pham	35
	Civil/Mechanical		Thomas Mihara	10	John Koch	57	Qingshan Wang	37	Dennis Schieber	29
	Instrumentation/Controls		Melvin Ridley	30	Curtis Horn	25	Adam Nichols	22	-	-
	<b>Sub Consultants</b>									
	Condition Assessment		Corrosion Probe, Inc.		-	-	-	-	On-Site Technical Services, Inc.	
	Hydraulic Analysis		-	-	-	-	-	-	Flow Science Incorporated	
	Surge Analysis		-	-	Scott Foster Engineering, Inc.		-	-	Mission Consulting Services	
	Survey		-	-	-	-	-	-	Coast Surveying, Inc.	
	<b>Insurance</b>									
	General Liability		Yes		Yes		Yes		Yes	
	Automobile		Yes		Yes		Yes		Yes	
	Workers' Compensation		Yes		Yes		Yes		Yes	

Note: This page is intentionally left blank.

PROPOSAL FOR

# Engineering Design Services for the East Irvine Zone 3 to 4 Pump Station Rehabilitation Project

SUBMITTED TO

Irvine Ranch Water District  
MARCH 31, 2026

March 31, 2026

Brian Waite, P.E.  
Engineering Manager – Treatment & Conveyance  
Irvine Ranch Water District  
15600 Sand Canyon Avenue  
Irvine, CA 92618

## **Subject: Proposal for Engineering Design Services for the East Irvine Zone 3 to 4 Pump Station Rehabilitation Project (PR 12565)**

Dear Mr. Waite:

Jacobs is pleased to submit this proposal to support Irvine Ranch Water District with engineering design services for the East Irvine Zone 3 to 4 Pump Station Rehabilitation Project. We understand the critical importance of this facility in sustaining Zone 4 pressures, serving upper pressure zones, and maintaining system reliability, particularly given the maximum allowable outage of only one to two days and the absence of a full bypass. Our team is prepared with proven strategies, specialized expertise, and a risk-focused delivery approach that is fully aligned with the requirements outlined in the RFP.

### **A Technical and Operationally Focused Approach**

Our approach integrates hydraulic modeling, mechanical rehabilitation, electrical and controls modernization, structural upgrades, and construction phasing from project inception. We will evaluate and validate alternatives such as reservoir level management, temporary bypass pumping, phased pump removal, staged MCC/switchboard cutovers, and controlled tie-ins, ensuring IRWD's operational reliability remains protected throughout construction. These elements mirror the scope and deliverables identified for preliminary and final design, including development of P&IDs/single-lines, surge/transient analysis, temporary power/implementation planning (TM-5), and a Class 3 to Class 2 cost estimate progression through 60/90/100% design.

### **An Irvine-Based Team, Assembled for IRWD's Highest-Risk Systems**

Jacobs has assembled an experienced local team specifically structured to address the highest-risk elements of the East Irvine Zone 3 to 4 Pump Station Rehabilitation, including phased implementation, temporary power, hydraulic validation, and modernization of critical mechanical, electrical, and control systems within an active facility. Our team brings deep experience working in operating water systems with strict outage limitations, including direct experience supporting IRWD and Southern California agencies.

Key team members include **Marielle Coquia, PE (Project Manager)**; **Deanie Ding, PE (Design Manager)**; **Ruoren Yu, PE (Hydraulic Modeling Lead)**; **Qingshan Wang, PE (Mechanical Lead)**; **Adam Nichols, PE (Electrical and I&C Lead)**; **Gino Nguyen, PE (Civil Lead)**; **Max Meng, PE (Structural Lead)**; **Kurt Lind (Condition Assessment Lead)**; and **Mike Hwang, PE (Quality Manager)**. Collectively, this team provides comprehensive expertise in pump station rehabilitation, surge and hydraulic modeling, switchboard and MCC replacement, PLC/SCADA modernization, canopy and foundation design, access and security improvements, and independent QA/QC aligned with IRWD standards.



### *Local Team!*

**The majority of this team is based in Jacobs' Irvine office, just a few miles from IRWD headquarters and the project site.**

This proximity provides immediate access to project leadership and discipline leads, enabling rapid response, frequent in-person coordination, and real-time resolution of design and field issues. During both design and construction, this local presence allows our team to work closely with IRWD staff and Operations to support phased implementation, temporary system coordination, and continuous facility operation.

By combining a highly experienced, pump-station-focused team with a strong local presence, Jacobs offers IRWD a delivery approach that reduces risk, improves coordination, and supports efficient, reliable implementation of this critical facility upgrade.

## Outage Mitigation Plans

Jacobs' outage mitigation strategy is built around IRWD's strict requirement that the East Irvine Zone 3 to 4 Pump Station cannot be offline for more than one to two days for any major tie-in and may not be taken fully out of service at any time except under controlled, pre-planned conditions. Our approach is driven by engineering-led phasing rather than contractor-led sequencing, ensuring every outage is predictable, brief, and operationally safe.

## Risk Management

Jacobs will implement a structured risk management program tailored to IRWD's outage, safety, and schedule constraints. We will maintain a live risk register with defined mitigation strategies, addressing key risks such as outage exceedance, long-lead procurement, arc flash and safety, constructability conflicts, and cost and schedule variance. Mitigation measures include tie-in matrices, rollback plans, temporary MCC and PLC cutovers, early vendor engagement, and multi-tier QA/QC reviews conducted for each milestone deliverable. Stage-gate risk workshops at PDR, 60%, and 90% will ensure risks are continuously evaluated and controlled.

## Cost Control

Jacobs will apply a disciplined cost management framework to maintain alignment with IRWD's budget. We will prepare Class 3 and Class 2 cost estimate at each major milestone, supported by cost variance tracking and early identification of cost drivers. By integrating hydraulic modeling, constructability review, and outage planning, we will refine design decisions to reduce uncertainty, minimize change orders, and provide cost transparency throughout the project lifecycle.

## Commitment to IRWD

Jacobs is committed to delivering a technically robust, constructible, and operationally reliable design that supports long-term asset performance. Our focus on phasing, surge mitigation, temporary systems, cost control, and outage management will reduce risk, protect service continuity, and ensure successful implementation.

We appreciate the opportunity to support IRWD and look forward to working closely with your Engineering and Operations teams. If you have any questions or need additional information, please contact Marielle Coquia, PE at 949.224.7626 or [marielle.coquia@jacobs.com](mailto:marielle.coquia@jacobs.com).

Sincerely,

  
**Marielle Coquia, PE**  
Project Manager  
[marielle.coquia@jacobs.com](mailto:marielle.coquia@jacobs.com)  
949.224.7626

  
**Deanie Ding, PE**  
Design Manager  
[deanie.ding@jacobs.com](mailto:deanie.ding@jacobs.com)  
949.224.7805

  
**Rich Nagel, PE**  
Principal-in-Charge  
[rich.nagel@jacobs.com](mailto:rich.nagel@jacobs.com)  
213.500.2333

# Table of Contents

## CONTENTS

	PG #
1. Scope	1
2. Understanding and Approach	6
3. Staff Team Qualifications	10
4. Related Project Experience	12

## APPENDICES

A. Resumes
B. Drawings List
C. Schedule
D. Level of Effort
E. Contract
F. Statements for Joint Venture, Public Works Requirement & Conflict of Interest
G. Insurance
H. Team Location & Availability

## Jacobs at a Glance

### JACOBS LEADERSHIP POSITION

TOP 500 DESIGN FIRMS 2025 ENGINEERING NEWS RECORD (ENR)



**3.5k**

PUMP STATIONS  
INCLUDING 200 IN  
THE PAST 5 YEARS

**#1** PURE  
DESIGNER

**500**

COLLECTION SYSTEMS DESIGNED/OPERATED  
IN NORTH AMERICA



**#2** DESIGN  
FIRM

**#2** WATER TREATMENT,  
DESAL PLANTS

**#3** WATER  
SUPPLY

# SCOPE

IRWD | East Irvine Zone 3 to 4 Pump Station Rehabilitation Project

Jacobs will provide engineering design services for rehabilitation of the East Irvine Zone 3 to 4 Pump Station, with a primary focus on modernization of mechanical, electrical, and control systems while maintaining operational continuity of this critical domestic water facility. The design will assume a maximum outage window of approximately one to two days for major tie-ins and will be structured to avoid full station bypass wherever feasible. The scope of work to be performed is described in the tasks below and is based on our approach described in Section 2.0 and prioritizes temporary power planning, phased implementation sequencing, and hydraulic validation to minimize risk and ensure reliable long-term operation.

## Task 1 – Project Management

Jacobs will provide comprehensive project management services throughout the design and bidding phases to adhere to the scope, schedule, budget, and quality objectives. Services will include development and maintenance of a detailed design schedule in Microsoft Project; preparation of monthly progress reports; coordination and facilitation of required meetings; and proactive communication with IRWD staff and Southern California Edison (SCE).

A structured QA/QC program will be implemented with independent technical reviews at each major milestone. Phasing and temporary power strategy will be treated as a central management element and tracked throughout design development to confirm outage windows and tie-ins are fully coordinated with IRWD operations.

### Deliverables

- **Project Management Plan** – Jacobs standard documentation of key elements for project management and execution, shared with IRWD for reference.
- **Monthly Status Reports** – Including descriptions of work progress relative to budget and schedule and invoices.
- **Updated Design Schedule (monthly)** – Delivered with monthly status reports, in Microsoft Project.
- **Meeting Agendas and Minutes** – Generally 2 days in advance for agendas, and within 3 days after meetings for meeting minutes.
- **QA/QC Documentation Logs** – In forms or checklists with names of independent reviewers and responding engineers.

## Task 2 – Preliminary Design (PDR – ~30%)

Jacobs will perform preliminary design services to evaluate existing conditions and define the technical basis for final design. The PDR phase will be driven by temporary power planning and construction sequencing constraints of the East Irvine Zone 3 to 4 Pump Station Rehabilitation Project.

## 2.1 Background Information Research and Review

Jacobs will initiate Task 2 by developing an information request matrix to guide collection of all relevant background data, including prior studies, related operational and vendor documents, design, construction, and as-built drawings.

A comprehensive review of the information and associated hydraulic model (in InfoWater) will provide the foundational context for identifying and understanding the approach for the condition assessment. During this effort, Jacobs will also identify data gaps significant to evaluations and document a plan to resolve them through focused follow-ups or reasonable assumptions for transparency. Jacobs will meet with IRWD to discuss missing information and identify if any site investigations or inspections to clarify or confirm data gaps.

To consolidate findings and requests, Jacobs will include their findings and summarize the available background information in the pertinent technical memorandums to be developed.

## 2.2 Coordination with Outside Agencies

At the time of the proposal, SCE is the only permitting agency identified to be engaged for the Project. Jacobs will start coordinating with SCE as soon as the Project scope is defined. Early engagement of the agency would ensure that their requirements are considered and incorporated into the design, to avoid delays in the permit acquisition process. Two virtual meetings are anticipated to walk through the Project and discuss any comments with SCE.

If required, other agencies related to reviewing architectural designs for the canopy, CCTV structure (if any), or perimeter fence will be contacted for project coordination.

## 2.3 Condition Assessment

Jacobs will perform a comprehensive mechanical condition assessment and develop the design basis for rehabilitation of the pump station's mechanical systems. To enhance the results of the condition assessment evaluation, Jacobs will review historical operations reports, such as findings from any operation rehabilitation activities and meet with the Operations and Maintenance (O&M) staff to better understand operational challenges and confirm any issues identified. The preliminary design will assume replacement of major mechanical equipment, subject to validation through condition assessment and hydraulic analysis. This includes evaluation and planned replacement of all vertical turbine pumps and motors, the surge tank (pending confirmation through transient analysis), the air compressor system, above-grade valves, and associated piping and appurtenances. The existing chemical feed system will be evaluated and incorporated into the design if deficiencies are identified during assessment.

The results of the Condition Assessment and associated costs using Class 5 Rough Order of Magnitude (ROM) for rehabilitation vs replacement will be presented in a technical memorandum.

### Deliverables:

- **Draft TM-1 Condition Assessment** – three (3) hard copies and one (1) electronic copy in PDF format
- **Final TM-1 Condition Assessment**– three (3) hard copies and one (1) electronic copy in PDF format

## 2.4 Hydraulic Evaluation

Hydraulic modeling will be provided to confirm pump sizing, which may result in adjustment from the existing 250 HP units, and to evaluate potential configuration alternatives such as 2+2 versus 3+1 duty/standby arrangements. A surge analysis and an optional intake hydraulic modeling (with computational fluid dynamics [CFD]) will also be performed to ensure system reliability for long-term operation. See additional discussion on the hydraulic evaluation and recommended CFD modeling effort in the Project Understanding and Approach.

## 2.5 Pump Selection

Based on the hydraulic modeling analysis, the replacement pump units will be selected and presented in the hydraulic analysis tech memo. Pumps will be multi-stage vertical turbine type, clean water services, suitable for canned installations in outdoor environments. The preferred pump specifications will also be discussed with IRWD to establish the basis of detailed design.

A technical memorandum will summarize the findings of the hydraulic evaluation and pump selection and include a cost estimate per American Association of Cost Engineers (AACE) Class 5 (-50% to +100% accuracy).

### Deliverables:

- **Draft TM-2 Hydraulic Analysis and Pump Selection** – three (3) hard copies and one (1) electronic copy in PDF format
- **Final TM-2 Hydraulic Analysis and Pump Selection** – three (3) hard copies and one (1) electronic copy in PDF format

## 2.6 Electrical and Controls Design Criteria

### 2.6.1 Project Codes, Standards, and SCE Requirements

Jacobs will evaluate relevant NEC and NFPA code compliance, arc flash hazard analysis and mitigation strategy, and protective relaying coordination. The findings, with the requirements through SCE coordination will be documented in a technical memorandum.

### 2.6.2 Electrical and Controls Design Criteria

Jacobs will develop the electrical, instrumentation and controls (I&C) design basis assuming full replacement of major electrical distribution and control components. This includes replacement of the main switchboard, motor starters (per IRWD standards), motor control centers, breakers, PLC cabinet and associated control panels, UPS battery system, the 12-inch magnetic flow meter located in the PRV vault, site lighting, and associated enclosures. At the time of this Proposal, we assume the replacement of conductors associated with the replaced equipment but existing buried conduits to be reused. If existing conduits are determined insufficient during the preliminary evaluation, Jacobs will coordinate with IRWD for incorporating it into the design scope for providing a complete functional facility. The design will maintain the existing 1600A service footprint unless otherwise directed, however, the demand load is much lower than the service size and it may be a consideration during preliminary design to reduce service size to save costs. The existing solar PV interface (301A capacity) will be confirmed but is not assumed to be in replacement scope unless officially directed by IRWD. Jacobs will also evaluate relocation of the reservoir level transmitter from the existing 35-foot vault location to improve safety and maintainability.

### 2.6.3 Implementation & Phasing Strategy

Jacobs will treat construction phasing and outage mitigation as the primary technical driver of design development. Given the pump station's critical role in maintaining Zone 4 system pressure and the constraint that the facility cannot be offline for a sustained period longer than approximately two days,

the design will be structured around controlled, limited-duration tie-ins. Detailed construction sequencing scenarios will be developed during preliminary design to evaluate pump removal strategies, staged equipment replacement, electrical gear cutovers within the existing footprint, and reservoir level management during implementation. Jacobs will develop a temporary power distribution strategy that allows electrical modernization to occur without extended service interruption. This will include evaluation of load transfer scenarios, temporary feeder routing, staged switchboard replacement, and sequencing of PLC migration by leveraging IRWD's temporary PLC equipment to minimize risk of control system downtime. Tie-in matrices and shutdown planning tables will be prepared to define allowable outage windows, required pre-construction preparation, and rollback contingencies. Phasing decisions will be integrated with proposed mechanical system modifications to ensure that system reliability is maintained throughout construction.

This structured approach ensures that outage exposure is minimized, contractor sequencing is clearly defined in the Contract Documents (i.e., Project Manual), and operational risks are identified and mitigated early in the design process. Up to 3 alternatives will be evaluated for various constraints and will include associated costs (AACE Class 5, -50% to +100% accuracy).

Electrical Controls and Design Criteria will be documented in three technical memorandums. The technical memorandums will be submitted three (3) hard copies and one (1) electronic copy in PDF format

#### Deliverables:

- **Draft TM-3 Relevant Project Codes, Standards and SCE Requirements** - three (3) hard copies and one (1) electronic copy in PDF format
- **Draft TM-4 Replacement Work: Design Criteria, Preliminary Sizing, and Layout** - three (3) hard copies and one (1) electronic copy in PDF format
- **Draft TM-5 Implementation Plan**- three (3) hard copies and one (1) electronic copy in PDF format
- **Final TM-3 Relevant Project Codes, Standards and SCE Requirements** - three (3) hard copies and one (1) electronic copy in PDF format
- **Final TM-4 Replacement Work: Design Criteria, Preliminary Sizing, and Layout** - three (3) hard copies and one (1) electronic copy in PDF format
- **Final TM-5 Implementation Plan**- three (3) hard copies and one (1) electronic copy in PDF format

## 2.7 Structural/Architectural Design Criteria

Jacobs will evaluate structural and architectural modifications required to support mechanical and electrical upgrades. Scope will include design of modifications to access hatches at the PRV vault, effluent flowmeter vault, and reservoir vault to improve maintenance access and safety. A new canopy structure will be designed to protect upgraded equipment from weather exposure. Equipment foundation modifications and structural supports required for new canopy, new mechanical or electrical installations will be evaluated and incorporated into the design. No comprehensive building structural evaluation is included unless directed by IRWD. Localized site grading may be proposed to direct stormwater runoff away from equipment. Jacobs will coordinate with IRWD Standards and any City of Irvine architectural requirements. Structural and architectural designs will be based on the appropriate layout or configurations to protect the equipment, design calculations, meeting code and city ordinance requirements. The design of this structure will be included in the Design Drawings included in the PDR.

## 2.8 Site Security Improvements

Jacobs will incorporate site security improvements consistent with the RFP requirements. Services will include development of CCTV conduit routing and coordination to support installation of new cameras at designated gate locations, and evaluation of upgrades to the existing perimeter chain-link fence to enhance security. Coordination with IRWD will clarify whether security equipment procurement will be included under this contract or provided separately, ensuring appropriate delineation of responsibilities within the design documents. Design of Site Security Improvements will be included in the Design Drawings included in the PDR.

## 2.9 Construction Schedule

Jacobs understands the complexity of implementing the upgrades and improvements while minimizing the down time of the pumping facility. A preliminary construction schedule will be developed based on output of the implementation and phasing strategy effort, under Item 2.6. Further discussion will also be made with IRWD to identify other constraints for scheduling the work. The Construction Schedule will be developed using Microsoft Project and include all construction activities related to the work, sequencing and phasing of work restrictions, submittal reviews, equipment fabrication lead times, permitting, inspections, and testing. Interim and major milestones will also be identified.

## 2.10 Opinion of Probable Construction Cost (OPCC)

AACE Class 3 (-20% to +30% accuracy) Opinion of Probable Construction Cost (OPCC) will be provided based on the Project scope and requirements defined in the preliminary design. The detailed cost breakdown will include facility direct costs, taxes, mobilization/demobilization, general conditions, contractor mark-ups, bonds and insurance, permitting, services during construction, and contingencies.

## 2.11 Preliminary Design Report

The Preliminary Design Report (PDR) will document the analyses, findings, and recommendations in the preliminary design (30%) phase. All technical memorandums, presentations, vendor information, and critical correspondence will be attached to the PDR. The PDR will also include a preliminary construction schedule, drawings and specifications lists anticipated for the final design.

### Deliverables

- **Draft and Final PDR** - three (3) hard copies and one (1) electronic copy in PDF format for each draft and final submittal
- PDR Appendices
- Technical Memorandums (TM-1 through TM-5)
- **Preliminary drawings including:** Mechanical Plan and Sections for Pump Replacement, Canopy Structure Plan and Sections, Vault Hatch Replacement Plan, Switchgear and MCC Elevations, Temporary Electrical System Plan, Reservoir Level Transmitter Relocation Plan, Single-Line Diagrams, and P&IDs
- List of the Technical Specification Sections (IRWD Standard Specifications)
- Preliminary Construction Schedule (Microsoft Project)
- Breakdown AACE Class 3 OPCC

## Task 3 – Final Design

Jacobs will prepare complete biddable and constructible Contract Documents in accordance with IRWD standards and requirements. The design will advance the phasing and temporary power plan developed during PDR and fully detail tie-in sequencing and outage windows. Jacobs will prepare the Project Manual consistent with IRWD standards and include the Final Service Plan. IRWD front-end documents, General Technical Specifications, and project-specific technical specifications as required for bidding and construction will be included in the Final Design packages.

Mechanical final design will include detailed pump selection,

pump station plans and sections, surge mitigation design, and associated piping and valve layout.

Electrical and I&C design will include detailed switchgear layouts, motor control center configurations, protective relaying coordination studies, arc flash mitigation measures, and PLC migration architecture. Final design will also include P&IDs, single-line diagrams, control equipment lists, I/O schedules, control narratives, loop descriptions, and documentation of SCADA integration consistent with IRWD automation standards. The Final SCE Service Plan will be obtained and incorporated into the design and included as an appendix of the Project Manual.

Civil and structural drawings will detail vault modifications, canopy structure, equipment foundations, site restoration, perimeter fencing, and coordination with underground utilities to support constructability and code compliance.

Updated AACE Class 2 (-15% to +20% accuracy) OPCCs and cost variance reports will be prepared at the 60%, 90%, and 100% design stages. During final design, the phasing and temporary power strategy developed in preliminary design will be advanced into fully detailed implementation documents. Construction sequencing diagrams, shutdown matrices, temporary system layouts, and cutover narratives will be incorporated into the Contract Documents to provide contractors with a clear roadmap for maintaining operations. Electrical cutovers, PLC migration, and mechanical tie-ins will be sequenced to limit any individual outage to the defined allowable window and to prevent cascading impacts to the distribution system. By embedding outage control measures directly into the design documents, Jacobs will reduce contractor ambiguity, minimize change order risk, and protect IRWD from extended service disruptions during implementation.

### Deliverables

- 60% Design Package (Drawings, Project Manual, Draft AACE Class 2 OPCC)
- 90% Design Package (Updated Drawings, Updated Draft OPCC, Variance Report)
- 100% Design Package (Biddable Contract Documents)
- Final Signed and Stamped Contract Documents
- AutoCAD Drawing Files
- Updated Construction Schedule
- Final AACE Class 2 OPCC (-15% to +20% accuracy) and Cost Variance Reports

## Task 4 – Bid Support

Jacobs will support IRWD during the bidding phase by responding to bidder questions, preparing up to three addenda, participating in the pre-bid meeting, and preparing conformed Contract Documents. If required, Jacobs will assist with post-bid evaluation in the event bids exceed the Engineer's estimate threshold.

### Deliverables

- Addenda (up to three)
- Responses to Bidder Questions
- Pre-Bid Meeting Materials
- Conformed Contract Documents
- Post-Bid Evaluation Memorandum (if required)

### Assumptions

- Maximum outage window limited to approximately 2 days per major tie-in.
- Major mechanical equipment replacement assumed unless condition assessment determines otherwise.
- No modifications to existing pump station inlet header system under the slab.
- The existing hydraulic model in InfoWater is up-to-date and calibrated to represent existing distribution networks.
- Reuse of existing buried conduits at pump station pad.
- Pump motor starter replacement assumed constant speed control; no VFDs included unless directed.
- Canopy to include new lighting.
- No changes to existing solar PV system unless directed.
- No building structural modifications included beyond the addition of a new canopy and hatch improvements.
- Surge analysis performed at engineering modeling level; advanced CFD for transient modeling not included.
- Permit fees reimbursed per RFP allowance. IRWD will coordinate and provide topographic mapping services to support civil improvements related to canopy installation, perimeter fence installation, and concrete pads.
- Implementation and integration of security cameras not included.
- No changes to site grading or drainage system.
- Topographic map of current conditions will be provided in AutoCAD platform will be provided by IRWD. If additional or updated topographic data is required to complete designs, IRWD will coordinate and obtain current topographic mapping to provide to Jacobs.
- Deliverables will be submitted in the formats specified in the RFP.
- Per the RFP, the scope of services extends through bid services and does not include engineering services during the construction phase. Jacobs can offer services during construction (SDC) to IRWD, which would typically include submittal/shop drawing review, responses to requests for information (RFIs), preparation of design change notices (DCNs) and preparation of record drawings. If desired, Jacobs can provide a scope and fee for these services based on further discussions with IRWD, if appropriate at this stage in the project.

# PROJECT UNDERSTANDING AND APPROACH

IRWD | East Irvine Zone 3 to 4 Pump Station Rehabilitation Project

## Understanding of the Core Challenge

The East Irvine Zone 3 to 4 Pump Station (PS) is a critical domestic water pumping facility in IRWD's water system. The most significant operational constraint is the maximum allowable outage of approximately two days, with no readily available bypass. In addition, there is no true isolation currently in place for individual pump intakes. As a result, *this project requires an engineering-driven phasing approach rather than construction-driven sequencing.*

Jacobs recognizes that the East Irvine/Portola Springs Zone 4 system is pressurized by the East Irvine 4 and Portola Springs 4 Reservoirs, which are supplied by two Zone 3 to 4 pump stations: the East Irvine Zone 3 to 4 Pump Station and the Portola Springs Zone 3 to 4 Pump Station. The East Irvine Zone 4 system also directly supplies four upper zones, Portola Springs Zone 6, Foothill Ranch Zone 6, Lake Forest Zone 4, and Irvine Zone 4R1, through pump stations or control valves. When the East Irvine Zone 3 to 4 Pump Station is offline, such upper zones are supplied solely by the Portola Springs Pump Station. Refer to **Figure 2.1** for an overview of the existing hydraulic zone network associated with East Irvine Zone 4. To meet system demand and maintain redundancy, it is critical to either maintain operation of the East Irvine Pump Station or provide temporary pumping from the Zone 3 reservoirs to Zone 4.

Jacobs has identified two potential approaches that will be further evaluated and discussed with IRWD during preliminary design to determine the most practical and reliable solution.

**Reservoir Level Management:** The first approach involves constraining the reservoirs' high water elevation below the pump station site grade elevation (approximately 463 ft). This could be done by adjusting the high-level setpoint of the reservoir feed control valve, preferably with a buffering room. This approach will allow individual pumps to be removed and replaced without interfering with other units. A modeling analysis using the existing InfoWater model could be performed to evaluate the impact on East Irvine Zone 3 system with a lower reservoir level setpoint. The key advantage of this approach is cost savings associated with pumping bypass system. However, it would not allow for full isolation of the suction header or pump cans, in case rehabilitation or modifications are required.

**Temporary Pumping:** The second approach involves running temporary bypass pumps to draw water from the Zone 3 reservoirs and pump to Zone 4 distribution system. There are existing locations for potentially connecting temporary pump suction and discharge piping (near the pressure reducing valve vault), which would be discussed with IRWD for feasibility and constraints. This approach would maintain reservoir levels (i.e., less impact on Zone 3 operation) and could mitigate the risk of spills through the open pump cans during construction. This will also allow for rehabilitation of pump cans if determined necessary through the condition assessment and the (optional) CFD modeling analysis. To mitigate the cost impact, the temporary pumping occurrence and duration will be evaluated throughout the design to avoid unnecessary spending.

**Figure 2.1 - Partial IRWD Hydraulic Schematic**

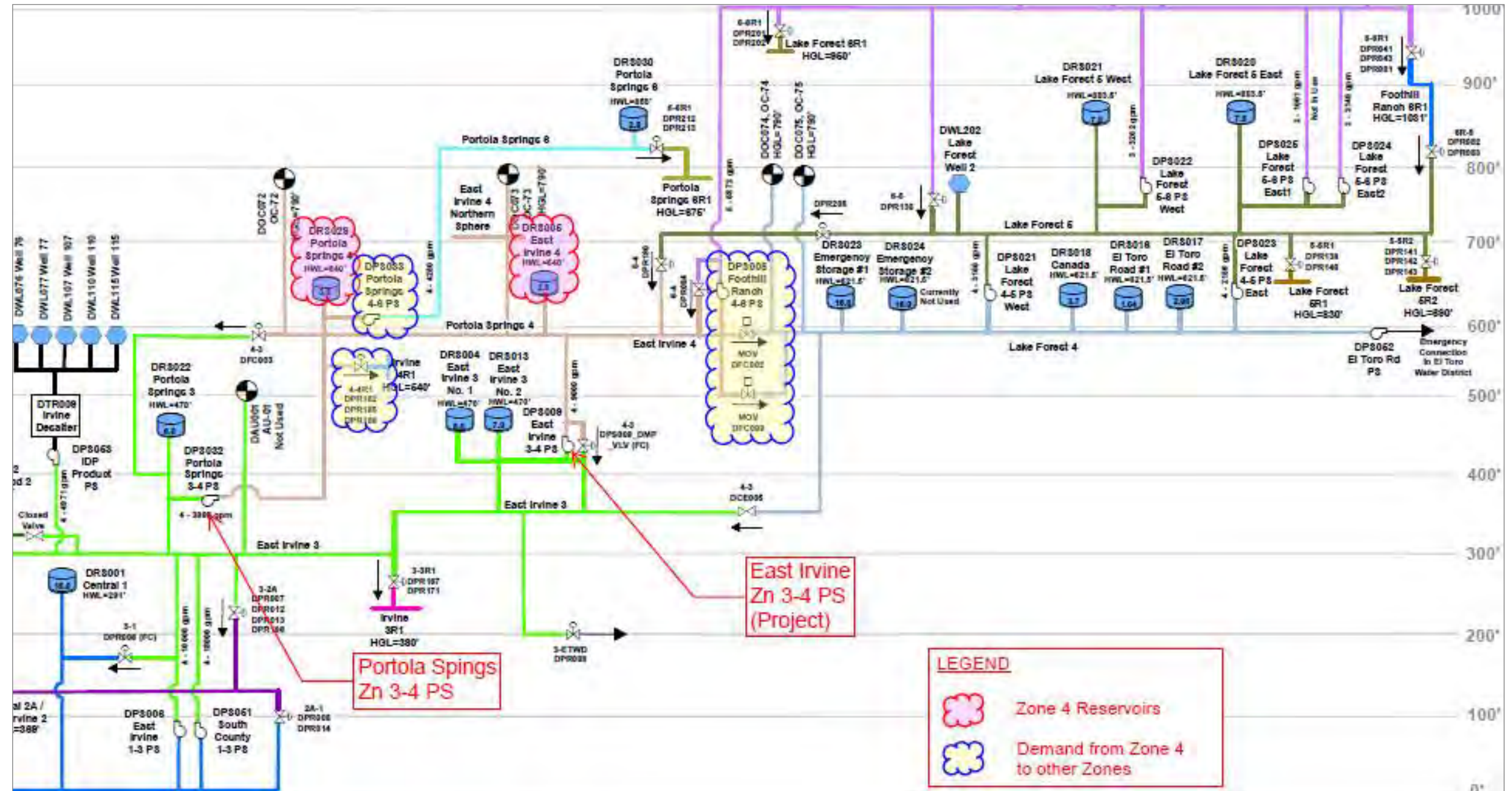

Jacobs also recognizes that existing pump conditions vary. One unit was under rehabilitation during the pre-proposal meeting, and another appeared to have been recently rehabilitated. The causes of past operational issues and premature pump failures will be investigated during preliminary design. Based on experience at similar facilities, *potential causes include*:

- **Pump intake issues**, such as insufficient net positive suction head (NPSH) or turbulent flow (vortices), leading cavitation and excess vibrations.
- **Inappropriate impeller design or changing hydraulic conditions in the system**, shifting the actual operating point(s) outside the preferred operating range.
- **Frequent pump cycling**, which exceeds electric motor’s limit.

During the condition assessment and hydraulic modeling stage, Jacobs will have one focus on a comprehensive analysis of the PS’s hydraulic conditions, as described in the following section.

## Delivery Strategy

Jacobs will structure the design as follows:

### Hydraulics First

The hydraulic analysis task will consist of three primary subtasks.

- **Distribution System Modeling Analysis:** First, distribution system modeling analysis will be performed to determine the preferred pump performance and duty/standby configuration. *The station currently operates as 2 duty and 2 standby pumps and could transition to 3 duty and 1 standby pump (configuration as intended in the original design), if needed.*

The results of this analysis will guide decisions related to pump rehabilitation or replacement, as well as define electrical and mechanical design criteria.

- **Evaluate Existing Open-Bottom Pump Can:** Second, we will evaluate the existing open-bottom pump can intake conditions based on Hydraulic Institute (HI) 9.8 design criteria. Optionally, a CFD model as illustrated in **Figure 2.2** will be built to analyze the existing pump intakes, aiming to identify any deficiencies contributing to operational issues and potential mitigation measures. We recommend CFD modeling to be included in the preliminary design because of 1) the criticality of the facility, 2) repeating premature pump failures, and 3) the relatively high flow capacity. Note that HI 9.8 requires a physical hydraulic model study to be conducted for open bottom canned pump with 5,000 gpm or higher flowrate per pump. For the East Irvine Zone 3 to 4 PS with 3,000 gpm unit capacity, we consider CFD as an informative tool for evaluating existing intake design and validating potential improvements. If deemed necessary by the study, we will make recommendations to improve pump operation for incorporating in the design.
- **Surge/Transient Analysis:** Third, although IRWD staff indicated hydraulic surges historically were not observed, a surge/transient analysis will be performed on the pump station discharge line to validate the surge protection system, such as the hydropneumatic tank volume and settings, to ensure long-term reliability.

The results of this hydraulic analysis will establish the basis for process-mechanical design and determine major electrical load requirements.

Figure 2.2 Pump Station CFD Model and Results

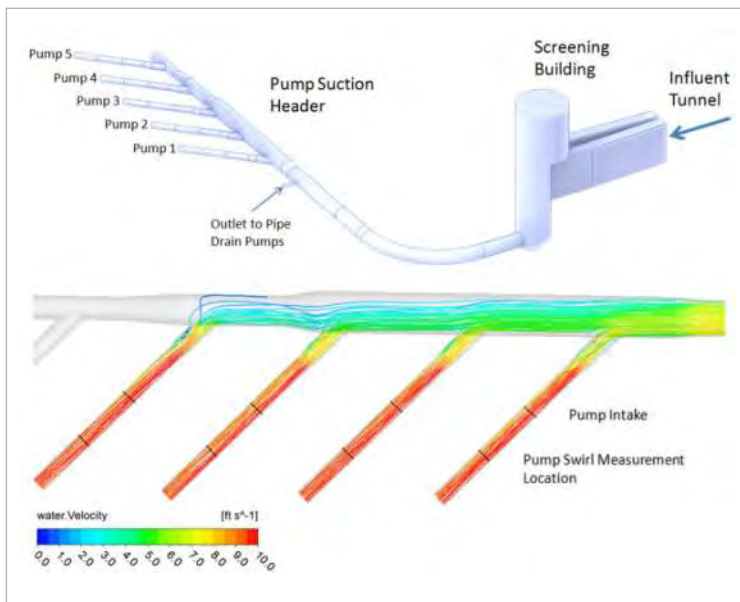

### Phasing-Driven Design

Jacobs will develop implementation alternatives during the Preliminary Design Report (PDR) phase.

#### Pump station rehabilitation sequencing strategy:

As described previously, we understand the criticality of maintaining the PS operation. Jacobs will develop alternatives to phasing the construction activities to be discussed with IRWD team and incorporated into the PDR. The pertinent requirements could then be included in the Project Manual as special provisions for the Project. The sequencing strategy may include the following considerations:

- As it is assumed that the power and control components would be replaced in place, temporary power distribution and controls are expected to be necessary during the shutdown period of these electrical components.

- Isolation of the vertical turbine pumps, piping sections, and surge tank will be evaluated during the condition assessment phase. Any special provisions or actions should be identified for isolating the components during construction.
- Construction of the new canopy structure is not anticipated to interfere with the PS operation but will be validated during preliminary design.

## Technical Execution

### Condition Assessment (TM-1)

Based on our understanding of the RFP scope, we plan to include the following items listed in **Table 2.1** in the proposed condition assessment. We will also include an allowance for additional investigation to address any unforeseen conditions.

**Table 2.1 Condition Assessment Impacts**

Description	Category	Potential Impacts
Surge protection system components	Mechanical & Instrumentation	Minimal (discharge system may lose surge protection temporarily)
Pump cans	Mechanical	Temporary shutdown of PS and drain of suction header
Reservoir flow control valve vault	Safety	None/minimal
Access hatches on pressure reducing valve vault and effluent meter vault	Safety	None/minimal
Chemical storage and feed systems	Mechanical & Safety	None/minimal

### Hydraulic Modeling (TM-2)

Hydraulic modeling will be performed as described above to validate system performance, confirm pump sizing, and establish the technical basis for design.

### Electrical & Controls Modernization (TM-3, TM-4, and TM-5)

In **TM-3, Relevant Project Codes, Standards and SCE Requirement**, Jacobs will evaluate code compliance with the existing facilities and the electrical upgrades planned for these facilities to ensure a safe and reliable system for operation and maintenance personnel. Additionally, Jacobs will ensure the preliminary design is in compliance with IRWD project and construction manuals. Based on the service size, the coordination with SCE is expected to be at a minimum since it is well above the expected demand load. Jacobs will coordinate with SCE by filling out their new online application process for replacement of electrical equipment and confirm temporary power can be accommodated.

For **TM-4, Replacement Work**, which requires design criteria, preliminary sizing and layout, Jacobs will evaluate the new layout by maintaining a compact footprint for the new electrical equipment and canopy. The approach would be to reuse existing conduit penetrations in the pump station slab to minimize installation time. Jacobs will evaluate providing a separate PLC enclosure versus including the control system equipment as part of the MCC lineup considering lead time, footprint, and ease of installation. Based on the results of the hydraulic model and the constructability of the process mechanical upgrades within the given shutdown period, the preliminary design for the size and number of duty pumps will be determined. Based on discussion with IRWD, Jacobs will determine the service size needed to handle current and future demand load at the site

### QA/QC Management of All Work Products

Mike will oversee the crucial aspect of quality assurance and quality control reviews for this project. One of his primary responsibilities is to develop a comprehensive quality management plan (QMP) That meticulously outlines the roles, responsibilities, and processes involved in QA/QC. This document will serve as a blueprint for maintaining the highest standards throughout the project. The Plan, Do, Check, Deliver graphic illustrates the quality review cycle for our project deliverables.

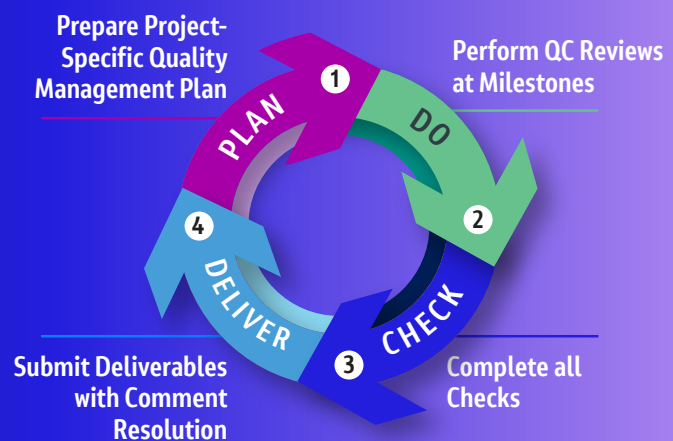

to efficiently size the electrical equipment as well as any other accommodation such as standby generator connection as well as the existing solar and potentially a second solar tap in the service gutter of the switchboard. For additional safety, Jacobs will investigate arc flash mitigation strategies for new electrical equipment such as the use of solid state trip units including maintenance mode, zone selective interlocking, current-limiting fuses, and arc-resistant equipment. Regarding motor control and the control system, Jacobs will work with IRWD to ensure new standards are met. Jacobs will work with IRWD to develop pre-procurement specifications for long-lead electrical equipment during preliminary design including potentially the temp MCC.

**TM-5, Implementation Plan**, is an important element of the design. Given the field conditions, there are not many options for keeping the station online. Below is **Table 2.2** with a list of options available. Due to the age of the equipment, Option 1 is not recommended to reuse the existing electrical equipment for temporary power. Similarly, Option 2 is not recommended since it doesn't meet project expectations.

**Table 2.2 – Temporary Power Options**

Opt.	Description	Pros	Cons
1	Reuse Existing MCC	<ul style="list-style-type: none"> <li>Less costly</li> <li>No change in components or number of pumps available</li> </ul>	<ul style="list-style-type: none"> <li>Aged equipment</li> <li>Potential Equipment failure during relocation causing expensive emergency operation</li> </ul>
2	Extended Shutdown	<ul style="list-style-type: none"> <li>Simpler construction</li> <li>No temporary power required</li> </ul>	<ul style="list-style-type: none"> <li>Does not meet project expectations</li> <li>More costly for keeping water distribution operational</li> </ul>
3	Rent Temp MCC	<ul style="list-style-type: none"> <li>Faster lead time</li> </ul>	<ul style="list-style-type: none"> <li>Dependent on construction schedule for rental costs</li> <li>Limited options</li> </ul>
4	Purchase Temp MCC	<ul style="list-style-type: none"> <li>Ability to customize project specific requirements</li> <li>Most flexibility for construction schedule</li> </ul>	<ul style="list-style-type: none"> <li>More expensive and longer lead time</li> <li>Will need to be stored after project and either used for spare parts or future projects if feasible</li> </ul>

Option 3 or 4 for temporary power is shown in **Figure 2.3** for location of pad mounted temporary power equipment and above grade pump feeders. During preliminary design, more discussion with IRWD will be needed to determine temp MCC components, number of motor starters, and ability to run on standby power. The final approach will be defined in the Drawings and Specifications for temporary power and PLC requirements.

**Figure 2.3 - location of pad mounted temporary power equipment and above grade pump feeders**

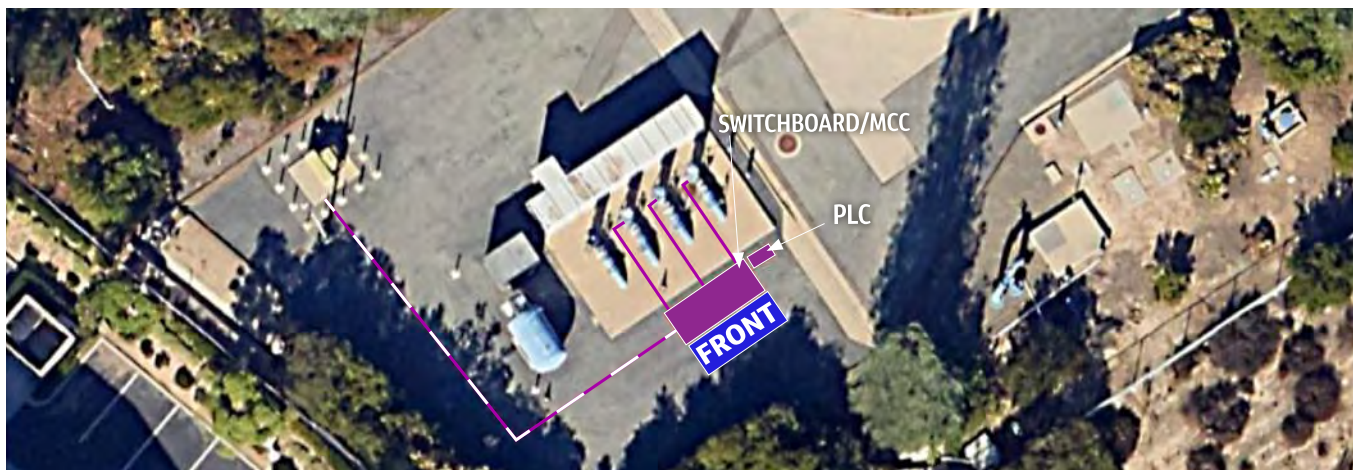

## Final Design, Cost Control & Risk Management

Jacobs will maintain a disciplined approach to cost and risk management throughout design by preparing Class 3 and Class 2 Opinions of Probable Construction Cost, tracking cost variances between design milestones, identifying long-lead equipment risks early, and aligning design with IRWD standards and operational requirements. Construction sequencing and implementation strategies developed during preliminary design will be advanced into detailed Contract Documents, including shutdown plans, temporary system layouts, and electrical cutover strategies. By integrating the findings of TM-1 through TM-5 into the design process, Jacobs will deliver a coordinated, constructable solution that minimizes outage risk, reduces contractor ambiguity, and ensures reliable implementation.



## Key Team Member Bio and Experience Matrix

Name, Project Role & Office Location	Key Team Member Bios	Relevant Project Experience	Relevant Professional Experience	Availability
<b>MARIELLE COQUIA, PE</b> Project Manager Irvine, CA	30+ years delivering pump station, groundwater, and treatment facility upgrades across Southern California. Experienced managing phased improvements in active facilities where maintaining operations is critical.	<ul style="list-style-type: none"> <li>• OCWD / City of Tustin – PFAS Treatment System, Pump Station Rehabilitation and Conveyance</li> <li>• SOCWA - J.B. Latham Advanced Wastewater Treatment Preliminary Design</li> <li>• EMWD - Perris Valley, Moreno Valley, and San Jacinto Valley Water Reclamation Facilities Sodium Hypochlorite Conversion</li> </ul>	<ul style="list-style-type: none"> <li>• Pump Station Infrastructure Delivery</li> <li>• Phased Construction in Operating Facilities</li> <li>• Multidisciplinary Design Coordination</li> <li>• Southern California Water Agency Delivery</li> </ul>	50%
<b>DEANIE DING, PE</b> Design Manager Irvine, CA	25+ years delivering multi-disciplinary water infrastructure upgrades including pump stations, treatment facilities, and conveyance systems. Experienced coordinating civil, mechanical, electrical, and operational requirements into practical design solutions.	<ul style="list-style-type: none"> <li>• OC San – Supplemental Engineering &amp; Support Staff Services Program</li> <li>• Cal Water – Infrastructure Program and Treatment Facility Upgrades</li> <li>• Port of Long Beach – Pump Station Upgrade Peer Review</li> </ul>	<ul style="list-style-type: none"> <li>• Multidisciplinary Design Integration</li> <li>• Constructability-Driven Design</li> <li>• Phased Design Development</li> <li>• Pump Station and Facility Coordination</li> </ul>	20%
<b>MIKE HWANG, PE</b> QA/QC Manager Irvine, CA	Experienced water infrastructure engineer providing independent technical review and QA/QC oversight. Ensures designs meet regulatory requirements, agency standards, and interdisciplinary coordination prior to milestone submissions.	<ul style="list-style-type: none"> <li>• IRWD Non-Potable Well PFAS Study</li> <li>• LASAN / LADWP – Donald C. Tillman Advanced Water Purification Facility</li> <li>• OCWD / City of Tustin – PFAS Treatment System, Pump Station Rehabilitation and Conveyance</li> <li>• OCWD – PFAS Treatment Testing and System Design Program</li> </ul>	<ul style="list-style-type: none"> <li>• Technical QA/QC</li> <li>• Design Validation and Risk Mitigation</li> <li>• Design Management</li> <li>• Hydraulic and System Performance Evaluation</li> </ul>	20%
<b>QINGSHAN WANG, PE</b> Mechanical Lead Irvine, CA	30+ years mechanical design experience including pump stations, equipment replacement, piping systems, and advanced treatment facilities. Experienced with vertical turbine pumps and surge protection systems.	<ul style="list-style-type: none"> <li>• LASAN / LADWP – Donald C. Tillman Advanced Water Purification Facility</li> <li>• Cal Water – Infrastructure Program and Treatment Facility Upgrades</li> <li>• MWD – CRA Pumping Plant Sump System Rehabilitation</li> </ul>	<ul style="list-style-type: none"> <li>• Vertical Turbine Pump Systems</li> <li>• Pump Station Equipment Replacement</li> <li>• Piping &amp; Surge Protection Design</li> <li>• Advanced Treatment Facility Mechanical Systems</li> </ul>	30%
<b>RUOREN YU, PE</b> Hydraulic Modeling Lead Los Angeles, CA	Specialist in pump system modeling and surge analysis for municipal water agencies. Experienced validating pump sizing and system performance during transient conditions.	<ul style="list-style-type: none"> <li>• IRWD – Multi-Zone Pump Station Hydraulic Modeling</li> <li>• IEUA – RP-1 Zone Pump Station Upgrades</li> <li>• Golden State Water – System Hydraulic and Water Quality Modeling</li> </ul>	<ul style="list-style-type: none"> <li>• Hydraulic Modeling for Pump Stations</li> <li>• Surge &amp; Transient Analysis</li> <li>• Pump Capacity Optimization</li> <li>• Pressure Zone System Analysis</li> </ul>	40%
<b>ADAM NICHOLS, PE</b> Electrical & I&C Lead Irvine, CA	20+ years designing electrical distribution and control systems for water facilities including switchgear replacement, PLC modernization, SCADA integration, and phased electrical cutovers.	<ul style="list-style-type: none"> <li>• OCWD / City of Tustin – PFAS Treatment System, Pump Station Rehabilitation and Conveyance</li> <li>• Cal Water – Infrastructure Program and Treatment Facility Upgrades</li> <li>• LASAN / LADWP – Donald C. Tillman Advanced Water Purification Facility</li> <li>• WRD - Goldsworthy Desalter Expansion</li> </ul>	<ul style="list-style-type: none"> <li>• Electrical Distribution Replacement</li> <li>• PLC / SCADA Modernization</li> <li>• Arc Flash &amp; Code Compliance</li> <li>• Phased Electrical Cutovers</li> </ul>	50%
<b>MAX MENG, PE</b> Structural Engineer Irvine, CA	Structural engineer experienced in equipment foundations, vault modifications, and structural retrofits supporting water and wastewater infrastructure upgrades.	<ul style="list-style-type: none"> <li>• Cal Water – Infrastructure Program and Treatment Facility Upgrades</li> <li>• WRD - Goldsworthy Desalter Expansion</li> <li>• LACSD - Sidestream Centrate Treatment Facility</li> </ul>	<ul style="list-style-type: none"> <li>• Equipment Foundations and Structural Retrofits</li> <li>• Seismic Compliance for Utility Facilities</li> <li>• Pump Station Structural Improvements</li> <li>• Integration with Mechanical and Electrical Systems</li> </ul>	50%
<b>GINO NGUYEN, PE</b> Civil Engineer Irvine, CA	27 years of civil design for water infrastructure including grading, drainage, yard piping, and underground utility coordination in active facilities.	<ul style="list-style-type: none"> <li>• LASAN / LADWP – Donald C. Tillman Advanced Water Purification Facility</li> <li>• El Toro Water District – Water Reclamation Plant Expansion</li> <li>• City of Oxnard – Advanced Water Purification Facility</li> </ul>	<ul style="list-style-type: none"> <li>• Site Civil Design for Pump Stations</li> <li>• Yard Piping and Utility Coordination</li> <li>• Stormwater and Drainage Design</li> <li>• Constructability in Active Facilities</li> </ul>	75%
<b>KURT LIND</b> Condition Assessment Lead Turlock, CA	30+ years operations and asset management experience performing facility condition assessments and supporting infrastructure upgrades in operating utility facilities.	<ul style="list-style-type: none"> <li>• WRD - Goldsworthy Desalter Expansion</li> <li>• City of Gresham - Wastewater Treatment Plant Equipment Condition Assessment</li> <li>• City of Bellingham - Post Point Wastewater Treatment Plant Headworks Condition Assessment and Bypass Project</li> </ul>	<ul style="list-style-type: none"> <li>• Facility Condition Assessment</li> <li>• CCTV and Security Systems Integration</li> <li>• Operational Risk Identification</li> <li>• Asset Evaluation and Upgrade Planning</li> </ul>	25%
<b>QUENTIN CLARK, PE</b> Constructability San Diego, CA	28+ years of experience delivering water infrastructure projects from design through construction, with a focus on constructability, sequencing, and maintaining operations in active facilities. Provides field-driven insight to align design with construction methods, reduce risk, and support efficient project delivery.	<ul style="list-style-type: none"> <li>• SDCWA - Mission Trails Flow Regulatory Structure II</li> <li>• City of Fresno - Recharge Fresno Capital Improvement Program</li> <li>• Chicago Dept. of Water Management - CIP Delivery Program</li> </ul>	<ul style="list-style-type: none"> <li>• Construction Sequencing and Phasing Strategies</li> <li>• Maintain Operations During Construction</li> <li>• Constructability Review and Field Coordination</li> <li>• Contractor Coordination and Risk Mitigation</li> </ul>	20%
<b>KEVIN BUTCHER</b> Cost Estimator Redding, CA	With 27 years of experience estimating complex water, wastewater, and pumping infrastructure, Kevin provides rigorous Class 1–4 cost leadership across planning, design, and construction. He delivers accurate, defensible estimates that align scope, sequencing, and operational constraints to support reliable capital decision-making.	<ul style="list-style-type: none"> <li>• City of San Diego - Metropolitan Biosolids Center Improvements</li> <li>• EMWD - Temecula Valley Regional Water Reclamation Facility Expansion</li> <li>• Lake Arrowhead CSD - Water Reclamation &amp; Integrated Water Resources Plan</li> </ul>	<ul style="list-style-type: none"> <li>• Specialized in Class 1–4 estimates</li> <li>• Lead estimator for major pump station, hydraulic structure, and treatment plant projects</li> <li>• Experienced in cost control during design and construction</li> </ul>	15%
<b>RICH NAGEL, PE</b> Principal-in-Charge Los Angeles, CA	35+ years leading Southern California water infrastructure programs including treatment and conveyance facilities. Provides executive oversight and ensures alignment with agency operational priorities.	<ul style="list-style-type: none"> <li>• WBMWD – ECLWRF Phase V Design-Build Expansion</li> <li>• WRD – Regional Brackish Water Reclamation Program</li> <li>• LVMWD – Pure Water Project</li> </ul>	<ul style="list-style-type: none"> <li>• Executive Oversight of Major Water Programs</li> <li>• Southern California Agency Leadership</li> <li>• Risk &amp; Program Governance</li> </ul>	25%

### Local Team. Local Knowledge. Reliable Delivery.















































































































Jacobs brings directly relevant experience delivering pump station rehabilitation, electrical and control system modernization, hydraulic analysis, and phased infrastructure upgrades within active water and wastewater facilities by team members. The projects presented in this section demonstrate our ability to replace and integrate mechanical and electrical systems including pumps, motors, piping, valves, switchgear, motor control centers (MCCs), and PLC/SCADA platforms while maintaining continuous operation of critical infrastructure.

Our experience spans a wide range of pumping facilities, from large-capacity raw and wastewater pump stations to booster stations and integrated treatment facility pumping systems. We have successfully performed pump selection and replacement, hydraulic modeling and surge analysis, and system optimization to ensure reliable long-term performance. In parallel, we deliver comprehensive electrical distribution and instrumentation and controls upgrades, including switchboard and MCC replacement, protection systems, and full PLC/SCADA modernization.

A key differentiator of Jacobs is our ability to execute these improvements within operating facilities where downtime must be minimized. Our teams develop phased construction strategies, temporary power solutions, and detailed cutover sequencing to maintain service continuity. We integrate constructability reviews, multidisciplinary coordination, and rigorous QA/QC processes throughout design and construction to reduce risk, protect schedule, and ensure successful implementation.

The projects on the following pages demonstrate Jacobs' ability to deliver complex, multidisciplinary upgrades that align directly with IRWD's project requirements, including pump station rehabilitation, electrical modernization, hydraulic and surge evaluation, and phased implementation in active facilities. *Collectively, these projects demonstrate Jacobs' ability to deliver reliable, constructible, and operationally resilient solutions for critical water infrastructure systems.*

 Main Attribute  Secondary Attribute

Project	Pump Station Rehabilitation	Pump Selection & Replacement	Hydraulic Modeling & Surge Analysis	Large Diameter Pipelines	Electrical Distribution Modernization	PLC & SCADA Modernization	Phased Implementation & Maintain Operations	Temporary Power & Cutover Sequencing	Condition Assessment & Facility Integration	Constructability Review	QA/QC & Multidisciplinary Coordination
<b>EchoWater Pump Station (PEPS)</b> Sacramento Regional County Sanitation District Sacramento, CA											
<b>Low Lake Level Pumping Station (L3PS)</b> Southern Nevada Water Authority (SNWA), Lake Mead, NV											
<b>San Diego International Airport Development Plan Airside Improvements</b> San Diego County Regional Airport Authority San Diego, CA											
<b>Pure Water San Diego (Morena Pump Station),</b> City of San Diego San Diego, CA											
<b>Sites Reservoir – HC Conveyance Facilities</b> Sites Project Authority Glenn County/Colusa County/Yolo County, CA											
<b>Delta Conveyance Project</b> Delta Conveyance Design and Construction Authority Sacramento, CA											
<b>Donald C. Tillman Advanced Water Purification Facility</b> City of Los Angeles (LASAN / LADWP) Los Angeles, CA											
<b>PFAS Treatment System &amp; Conveyance</b> Orange County Water District / City of Tustin Tustin, CA											
<b>WRD Goldsworthy Desalter Expansion &amp; Brackish Wells Water Replenishment District of Southern California</b> Torrance, CA											
<b>Treatment &amp; Pumping Plants Facility Security Enhancement</b> Metropolitan Water District of Southern California Southern, CA											

## California Water Service Pump Station and Electrical System Upgrade Program

STATEWIDE, CALIFORNIA | 2020-2027 | PROGRAM VALUE: OVER \$1 BILLION

Jacobs provides long-term engineering, design, and construction support for California Water Service's system-wide capital improvement program. This includes **over sixty task orders across 24 districts, each involving some combination of pump station rehabilitation, electrical distribution replacement, pipeline integration, and system modernization.**

### CLIENT REFERENCE

**Karina Winje, PE – Construction Program Quality Manager, California Water Service**  
1955 S. Atlanta Blvd., Monterey Park, CA 91754 | kwinje@calwater.com | 310-257-1486 (office) | 424-488-4984 (cell)



### Sacramento Regional County Sanitation District Primary Effluent Pump Station

*Project included civil and mechanical design of large pumping stations and preliminary engineering and the preparation of plans, specifications, and cost estimates. Jacobs utilized 3D modeling to provide the visualization of piping and other conflicts required for Jacobs and SRCSD to work together and develop solutions consisting of design concepts and details.*

### PUMP STATION & MECHANICAL SCOPE

Jacobs has executed upgrades involving:

- Replacement of **end-of-life pumps and motors**, including integration of new pump curves, suction/discharge modifications, and hydraulic performance balancing.
- Rebuilds of existing pump stations including **pump bowl replacements**, column pipe renewal, and vertical turbine pump installation.
- Piping reconfiguration to improve operational flexibility, reduce head losses, and streamline maintenance access.

#### Representative projects include:

- **PV15 Station Rebuild** – installation of new pumps and motors with integration into existing wet-well and suction/discharge header geometry.
- **Hermosa Redondo (HR027) Station Rebuild** – rehabilitation of pump station building, mechanical equipment, and chemical facility upgrades.

### ELECTRICAL DISTRIBUTION & CONTROLS SCOPE

Jacobs performs comprehensive electrical modernization efforts such as:

- Replacement of **switchboards, motor control centers, panelboards**, and standalone electrical service cabinets.
- Migration of legacy control systems to modern **programmable logic controller architectures**.
- **Supervisory control and data acquisition upgrades** across multiple water districts.
- Short circuit, arc-flash, and coordination updates to ensure compliance with modern standards.
- Electrical tie-ins and conduit/wiring renewal across multiple sites.

### PHASING, TEMPORARY POWER & CONSTRUCTION SEQUENCING

Because California Water Service systems must remain online, Jacobs develops:

- Detailed **temporary power plans** to maintain pump station operability during electrical upgrades.
- **Phased MCC/switchboard cutovers** for minimal outage durations.
- Sequencing plans for pump replacement to maintain pressure zone stability.

### PROJECT OUTCOMES

- Improved system reliability and modernization of aging stations.
- Minimized service disruptions through careful phasing.
- Accelerated delivery using standardized electrical and mechanical design approaches.
- Enhanced regulatory compliance related to safety, electrical, and sanitary requirements.

### KEY PERSONNEL

Deanie Ding, PE; Adam Nichols, PE; Michael Wang, PE; Max Meng, PE; Minette Lava, EIT

## Los Angeles Sanitation and Environment & Los Angeles Department of Water and Power Donald C. Tillman Advanced Water Purification Facility

CITY OF LOS ANGELES, CALIFORNIA | 2023 - 2028 | \$740 MILLION

Jacobs is delivering the full-scale Advanced Water Purification Facility including **major pumping, electrical, and control system infrastructure** integrated into the existing water reclamation plant.

### CLIENT REFERENCE

**Ryan Thiha, PE – Los Angeles Sanitation and Environment**  
ryan.thiha@lacity.org, 323-342-6229  
6100 Woodley Avenue, Van Nuys, CA 91406

**Jesus Gonzalez – Los Angeles Department of Water and Power**  
111 N. Hope St. Los Angeles, CA 90012  
jesus.gonzalez@ladwp.com, 213-367-1120



### PUMP STATIONS & CONVEYANCE SCOPE

- Design and integration of the **Balboa Pump Station** and **Sepulveda Pump Station**, which convey advanced treated water to the Hansen Spreading Grounds. Pumping systems engineered to support 30-45 million gallons per day, requiring:
  - High-reliability vertical turbine or horizontal pumping selections
  - Surge control strategies tied to variable flow patterns
  - Hydraulic routing, pump system balancing, and flow equalization integration

### ELECTRICAL DISTRIBUTION & POWER SYSTEMS SCOPE

The facility includes one of the most complex water-sector electrical systems in Southern California, featuring:

- New **medium-voltage service**, main switchgear, and distribution switchboards.
- Replacement and expansion of **motor control centers** for the pump stations, advanced treatment systems, and equalization basins.
- **Variable-frequency drives for all major pumping systems**, including harmonic mitigation and protective relaying.
- **Transformers, uninterruptible power supply, protective relays**, and grounding upgrades.
- Long-lead equipment procurement and integration into the Progressive Design-Build commercial structure.



**Woodland Davis Clean Water Agency (WDCWA) Regional Water Treatment Plant (RWTP), Woodland, CA - 30 MGD Regional Water Treatment Facility and treated water pump stations** - The project provides improved water supply reliability and water quality while assisting with cities compliance to strict state and federal water quality and wastewater discharge regulations.

### CONTROLS, AUTOMATION & SCADA SCOPE

- Facility-wide **programmable logic controller** modernization aligned with Los Angeles Department of Water and Power standards.
- Development of control narratives for pump station cycling, flow balancing, and advanced treatment response.
- Full **SCADA integration** across the advanced treatment, storage, and pumping systems ensuring consistent operator visibility and fail-safe operation.

### PHASED IMPLEMENTATION & MOPO REQUIREMENTS

Work is executed under a **Maintenance of Plant Operations (MOPO)** framework including:

- Multi-stage tie-ins of new electrical systems.
- Parallel construction next to active basins and pump stations.
- Temporary bypassing, isolation, and power maintenance for uninterrupted operation.

### PROJECT OUTCOMES

- Expanded purified water supply capacity.
- Minimized plant outages through advanced sequencing.
- Integrated pumping, treatment, electrical, and SCADA systems for long-term resilience.
- National award-winning design.

### KEY PERSONNEL

Mike Hwang, PE; Adam Nichols, PE; Qingshan Wang, PE; Gino Nguyen, PE; Jianwei Zhang, PE; Ping Tian, PE, GE

## Orange County Water District and City of Tustin PFAS Treatment System and Conveyance Project

Tustin, California | 2021 – In Construction | \$948,904

### CLIENT REFERENCE

**Fernando Almario – Project Manager, Orange County Water District**  
falmario@ocwd.com, 714-378-8220  
18700 Ward St., Fountain Valley, CA 92708

Jacobs designed and supported construction for a centralized treatment and pumping facility integrating multiple wellfields and new electrical/control systems.

### PUMP STATION & CONVEYANCE SCOPE

- Over **11,000 linear feet of new raw-water pipelines and 2,000 linear feet of distribution piping** designed to supply and discharge flow from four well sources.
- Upgrades to the existing **onsite booster pump station** were designed to provide complete replacement of existing 60 HP, 900 gpm pumps, with five, new, 200 HP pumps with 8,000 gpm of total finished water pumping capacity. The new pump station improves system reliability and accommodates varying flow and pressure conditions associated with multi-well operation. Hydraulic evaluations were conducted to optimize flow distribution across treatment trains and ensure consistent performance under variable operating scenarios.

### ELECTRICAL DISTRIBUTION SCOPE

- Complete **replacement of the main switchboard** to accommodate new pumping and treatment loads.
- **Motor control center replacement** sized for all booster pumps, PFAS treatment systems, nitrate removal systems, and chemical systems.
- Integration of new lighting panels, branch circuits, conduit/wire, and site power improvements.
- Coordination with **Southern California Edison** for electrical service modifications.

### CONTROLS & SCADA SCOPE

- Full migration from aging SLC 5/04 controllers to modern **CompactLogix programmable logic controllers** utilizing a device-level ring network.
- New distributed I/O, communication architecture, and programming.
- Unified supervisory control and data acquisition integration of wells, pumps, chemical systems, and ion-exchange processes.

### PHASED IMPLEMENTATION & TEMPORARY POWER

- Detailed phasing to keep existing wells in service during construction.
- Temporary power strategies to maintain pumping during motor control center replacement.
- Sequencing of pipeline tie-ins, switchboard changes, and cutovers to minimize disruption.

### PROJECT OUTCOMES

- **Achieved regulatory compliance under tight timelines.**
- **Improved system reliability, pumping performance, and treatment redundancy.**
- **Delivered a scalable PFAS treatment facility supporting future regulatory needs.**

### KEY PERSONNEL

Marrielle Coquia, PE; Michael Hwang, PE; Adam Nichols, PE; Michael Wang, PE; Minette Lava, EIT; Qingshan Wang, PE; Jianwei Zhang, PE; Ping Tian, PE, GE

## Water Replenishment District of Southern California Goldsworthy Desalter Expansion and Brackish Wells

Torrance, California | 2012 – 2016 | \$550,000

### CLIENT REFERENCE

**Everett Ferguson, Jr., PG, CHG – Water Replenishment District of Southern California**  
eferguson@wrd.org, 562-275-4241  
4040 Paramount Blvd., Lakewood, CA 90712

### PUMP & WELL SYSTEM SCOPE

- Siting and design of **two high-capacity 2,200-gpm extraction wells**, including casing design, screen selection, pump sizing, and aquifer drawdown evaluation. Hydraulic and system modeling to ensure compatibility with existing conveyance and treatment facilities.
- Integration of new pumping infrastructure into the existing desalter system.

### ELECTRICAL & CONTROL SYSTEM SCOPE

- Electrical design for well power, pump control, and treatment facility integration.
- Condition assessment of reverse-osmosis system operation including cleaning frequency, pressure performance, and fouling trends.

### PROJECT OUTCOMES

- **Improved groundwater reliability.**
- **Enhanced system performance through hydraulic refinements.**
- **Provided both short-term operational improvements and long-term design recommendations based on membrane fouling studies.**

### KEY PERSONNEL

Adam Nichols, PE; Kurt Lind; Minette Lava, EIT; Ping Tian, PE, GE, Michael Hwang, PE; Michael Wang, PE



## San Diego County Regional Airport Authority San Diego International Airport – Airside Improvements

San Diego, California | 2009 – Ongoing | \$1.2 Billion Program

### CLIENT REFERENCE

**Robert Bolton, AIA – Director of Airport Design and Construction, San Diego County Regional Airport Authority**  
P.O. Box 82776, San Diego, CA 92138  
619-400-2935, rbbolton@san.org

### PUMP STATION SCOPE

- Design of stormwater pumping systems tied to a large underground cistern (~970,000 gallons).
- **Two independent pump sets with variable-frequency drives** designed to either:
  - Pump stormwater to the Central Utility Plant for reuse, or
  - Discharge to infiltration islands to avoid pollutant loading to San Diego Bay.
 Hydraulic modeling, transient response consideration, and pump control strategies.

### ELECTRICAL DISTRIBUTION SCOPE

- Extension and reinforcement of the **12-kilovolt primary electrical loop** to support new airside facilities.
- Installation of **switchboards, transformers, medium-voltage switchgear**, motor control centers, and variable-frequency drives for all major pumping systems.
- Integration of redundant power systems, uninterruptible power supply, and protection coordination.

### INSTRUMENTATION, CONTROLS & SCADA SCOPE

- Full **PLC-based control system design**, including device-level network architecture for resiliency.
- SCADA and building management system integration across pump stations and stormwater systems.
- Factory acceptance testing, site acceptance testing, commissioning, and operator training.

### PHASED IMPLEMENTATION & TEMPORARY POWER

- Pump station and electrical upgrades installed while maintaining uninterrupted airfield operations.
- Temporary power distribution and **cutover sequencing** to ensure zero-down-time transitions.

### PROJECT OUTCOMES

- **Implemented a resilient and sustainable stormwater reuse system.**
- **Maintained full airport operations during construction.**
- **Delivered coordinated pumping, electrical, and control systems for mission-critical airfield infrastructure.**

### KEY PERSONNEL

Adam Nichols, PE; Michael Wang, PE; Qingshan Wang, PE; Mike Hwang, PE



APPENDIX B

# Drawings List

**Jacobs**

Challenging today.  
Reinventing tomorrow.

# APPENDIX B - DRAWING'S LIST

IRWD | East Irvine Zone 3 to 4 Pump Station Rehabilitation Project

<b>DRAWING TITLE</b>		
<b>GENERAL</b>		
1	G-1	TITLE SHEET
2	G-2	LOCATION MAP & DRAWING INDEX
3	G-3	ABBREVIATIONS
4	G-4	CIVIL LEGEND & NOTES
5	G-5	STRUCTURAL NOTES
6	G-6	ARCHITECTURAL LIFE SAFETY PLAN
7	G-7	MECHANICAL LEGEND & NOTES
8	G-8	ELECTRICAL LEGEND 1
9	G-9	ELECTRICAL LEGEND 2
10	G-10	INSTRUMENTATION AND CONTROLS LEGEND 1
11	G-11	INSTRUMENTATION AND CONTROLS LEGEND 2
<b>CIVIL</b>		
12	C-1	OVERALL SITE PLAN
13	C-2	PUMP STATION SITE PLAN
14	C-3	STANDARD DETAILS
<b>DEMOLITION</b>		
15	D-1	DEMOLITION PLAN
16	D-2	DEMOLITION DETAILS
<b>STRUCTURAL</b>		
17	S-1	CANOPY ROOF AND FOUNDATION PLANS
18	S-2	CANOPY STRUCTURE SECTIONS AND DETAILS
19	S-3	HATCH REPLACEMENT DETAILS
20	S-4	STANDARD STRUCTURAL DETAILS
<b>PROCESS MECHANICAL</b>		
21	M-1	PUMP STATION PLAN
22	M-2	PUMP STATION SECTIONS
23	M-3	MECHANICAL DETAILS
24	M-4	STANDARD MECHANICAL DETAILS 1
25	M-5	STANDARD MECHANICAL DETAILS 2
<b>ELECTRICAL</b>		
26	E-1	ELECTRICAL SITE PLAN
27	E-2	ELECTRICAL DEMOLITION PLAN
28	E-3	ONE-LINE DIAGRAM
29	E-4	SWITCHGEAR & MCC ELEVATIONS, AND PANEL SCHEDULES
30	E-5	PUMP STATION POWER PLAN
31	E-6	PUMP STATION LIGHTING AND GROUNDING PLAN
32	E-7	CONDUIT AND DUCTBANK SCHEDULES
33	E-8	CONTROL SCHEMATIC DIAGRAMS 1
34	E-9	CONTROL SCHEMATIC DIAGRAMS 2
35	E-10	STANDARD ELECTRICAL DETAILS
<b>INSTRUMENTATION</b>		
36	I-1	CONTROL PANEL LAYOUT AND BILL OF MATERIALS
37	I-2	CONTROL PANEL - POWER DISTRIBUTION
38	I-3	PUMP STATION P&ID 1
39	I-4	PUMP STATION P&ID 2
40	I-5	INSTRUMENTATION DETAILS



APPENDIX C

# Schedule

**Jacobs**

Challenging today.  
Reinventing tomorrow.

# APPENDIX C - SCHEDULE

IRWD | East Irvine Zone 3 to 4 Pump Station Rehabilitation Project

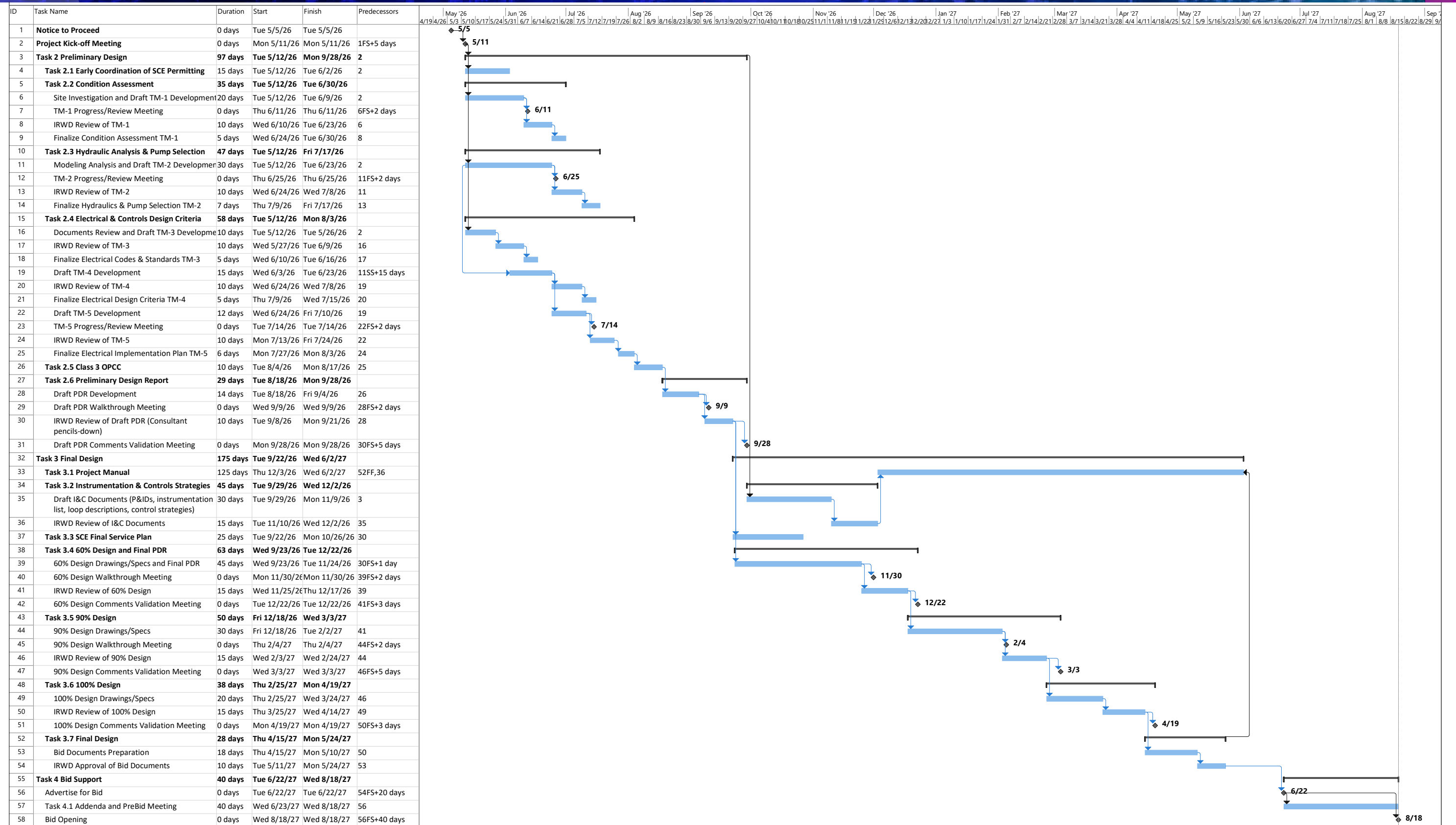

Project: East Irvine Zone 3 to 4 PS Rehab  
Date: Tue 3/17/26

Task	Summary	Inactive Milestone	Duration-only	Start-only	External Milestone	Manual Progress
Split	Project Summary	Inactive Summary	Manual Summary Rollup	Finish-only	Deadline	
Milestone	Inactive Task	Manual Task	Manual Summary	External Tasks	Progress	

The image shows an industrial control room. In the foreground, there is a white folding table with several documents and a clipboard on it. Behind the table, there are several large, grey electrical control panels mounted on a wall. The panels have various buttons, switches, and indicator lights. One panel has a prominent red emergency stop button. To the right, there are vertical pipes and conduits, and a fire extinguisher is visible. The overall lighting is dim, with a blue tint on the left side of the image.

APPENDIX D

# Level of Effort

**Jacobs**

Challenging today.  
Reinventing tomorrow.

# APPENDIX D - LEVEL OF EFFORT

IRWD | East Irvine Zone 3 to 4 Pump Station Rehabilitation Project

Task No.	Team Member Name, Role on Project Billing Classification	R. Nagel, Principal-in-Charge Principal-in-Charge	M. Coquia, PM Principal Professional 2	D. Ding, DM Principal Professional 1	M. Hwang, STC or QA/QC Principal Professional 1	Q. Wang, Mechanical Principal Professional 2	M. Meng, Structural Principal Professional 1	R. Yu, Hydraulics Principal Professional 2	P. Tian, Geotechnical Principal Professional 1	G. Nguyen, Civil Principal Professional 1	A. Nichols, Elec / I&C Principal Professional 1	F. Gist, Security Principal Professional 2	R. Smith, Architectural Principal Professional 1	L. Minette, Project Engineer (Civil) Staff Professional 2	J. Zhang, Project Engineer (Mechanical) Sr. Professional 1	D. Singh, Project Engineer (Electrical) Staff Professional 2	GID, Project Engineer (Instrumentation) Staff Professional 2	K. Nielsen, Project Engineer (Hydraulics) Principal Professional 2	J. Minor, Digital Delivery Lead Proj. Professional 1	GID, Structural/Arch CAD Technician	D. Patel, Civil CAD Technician	D. Cave, Mech CAD Engineering Technician	K. Wolny, Mech CAD Technician	R. Sharma, E/I CAD Technician	K. Butcher, Cost Estimator Proj. Professional 1	C. Perrine, Specs Processor Proj. Professional 1	TBD, Admin Admin/Clerical	LABOR HOURS SUBTOTAL	
<b>1.0</b>	<b>Project Management</b>																												
1.1	Preparation of Project Status Reports	2	36																										38
1.2	Project Design Schedule (Monthly)		16	24																									40
1.3	Meetings/Workshops (total of 29)		62	16	4	36	20	22		20	40		4														31	255	
	<b>TASK 1 SUBTOTAL</b>	<b>2</b>	<b>114</b>	<b>40</b>	<b>4</b>	<b>36</b>	<b>20</b>	<b>22</b>	<b>0</b>	<b>20</b>	<b>40</b>	<b>0</b>	<b>4</b>	<b>0</b>	<b>0</b>	<b>0</b>	<b>0</b>	<b>0</b>	<b>0</b>	<b>0</b>	<b>0</b>	<b>0</b>	<b>0</b>	<b>0</b>	<b>0</b>	<b>0</b>	<b>31</b>	<b>333</b>	
<b>2.0</b>	<b>Preliminary Design</b>																												
2.1	Background Information Research					4				2	4		2															12	
2.2	Early Coordination for SCE Permitting										12																	12	
2.3	Condition Assessment (TM 1)		4		4	20	4				4															2	38		
2.4	Hydraulic Analysis		4		4	4		40										40								2	94		
2.5	Pump Selection (TM 2)					4		8																				12	
2.6	Electrical & Controls Design Criteria (TMs 3-5)		4		4						36															6	50		
2.7	Structural/Architectural		4				18						14															36	
2.8	Site Security Improvements		4							6	8					8												26	
2.9	Construction Schedule		4	20		5	2				6																	37	
2.10	Class 3 OPCC		4			4	4	4		4	4														24	7	55		
2.11	Preliminary Design Report	2	22	22	22	40	8	8	3	8	70	8	4	20	43	32	32	8	13	15	18	23	23	78	24	7	10	532	
	<b>TASK 2 SUBTOTAL</b>	<b>2</b>	<b>50</b>	<b>42</b>	<b>34</b>	<b>81</b>	<b>36</b>	<b>60</b>	<b>3</b>	<b>20</b>	<b>144</b>	<b>8</b>	<b>20</b>	<b>20</b>	<b>43</b>	<b>40</b>	<b>32</b>	<b>48</b>	<b>13</b>	<b>15</b>	<b>18</b>	<b>23</b>	<b>23</b>	<b>78</b>	<b>24</b>	<b>7</b>	<b>20</b>	<b>904</b>	
<b>3.0</b>	<b>Final Design</b>																												
3.1	Project Manual		8	8	8	12	12			12	40																	100	
3.2	I&C Strategies										24						8											32	
3.3	SCE Final Service Plan									8	16																	24	
3.4	60% Design (including OPCC)	4	20	20	24	24	24	6	2	8	42		4	28	30	28	24		13	18	24	18	18	58	24	12	11	484	
3.5	90% Design (including OPCC & Construction Schedule)	2	28	24	25	26	24	4	2	8	42		4	28	30	28	24		13	18	24	18	18	60	24	12	11	497	
3.6	100% Design (including OPCC)		56	48	42	24	24	6	3	6	76		9	36	20	52	44		35	30	36	18	18	136	64	28	28	839	
3.7	Final Design		20	24	22	10	18		2	8	40		4	20	30	28	20		13	14	18	14	13	58	24	10	10	420	
	<b>TASK 3 SUBTOTAL</b>	<b>6</b>	<b>132</b>	<b>124</b>	<b>121</b>	<b>96</b>	<b>102</b>	<b>16</b>	<b>9</b>	<b>50</b>	<b>280</b>	<b>0</b>	<b>21</b>	<b>112</b>	<b>110</b>	<b>136</b>	<b>120</b>	<b>0</b>	<b>74</b>	<b>80</b>	<b>102</b>	<b>68</b>	<b>67</b>	<b>312</b>	<b>136</b>	<b>62</b>	<b>60</b>	<b>2396</b>	
<b>4.0</b>	<b>Bid Support</b>																												
4.1	Addenda and PreBid Meeting	2	16	8	4	20	12	8		8	24																	102	
	<b>TASK 4 SUBTOTAL</b>	<b>2</b>	<b>16</b>	<b>8</b>	<b>4</b>	<b>20</b>	<b>12</b>	<b>8</b>	<b>0</b>	<b>8</b>	<b>24</b>	<b>0</b>	<b>0</b>	<b>0</b>	<b>0</b>	<b>0</b>	<b>0</b>	<b>0</b>	<b>0</b>	<b>0</b>	<b>0</b>	<b>0</b>	<b>0</b>	<b>0</b>	<b>0</b>	<b>0</b>	<b>0</b>	<b>102</b>	
<b>5.0</b>	<b>OPTIONAL</b>																												
5.1	Optional: Task 2.12 CFD Analysis of Pump Intakes	2	2		2	4		8										120										138	
	<b>TASK 5 SUBTOTAL</b>	<b>2</b>	<b>2</b>	<b>0</b>	<b>2</b>	<b>4</b>	<b>0</b>	<b>8</b>	<b>0</b>	<b>0</b>	<b>0</b>	<b>0</b>	<b>0</b>	<b>0</b>	<b>0</b>	<b>0</b>	<b>0</b>	<b>120</b>	<b>0</b>	<b>0</b>	<b>0</b>	<b>0</b>	<b>0</b>	<b>0</b>	<b>0</b>	<b>0</b>	<b>0</b>	<b>138</b>	
	<b>TOTAL (TASKS 1-4)</b>	<b>12</b>	<b>312</b>	<b>214</b>	<b>163</b>	<b>233</b>	<b>170</b>	<b>106</b>	<b>12</b>	<b>98</b>	<b>488</b>	<b>8</b>	<b>45</b>	<b>132</b>	<b>153</b>	<b>176</b>	<b>152</b>	<b>48</b>	<b>87</b>	<b>95</b>	<b>120</b>	<b>91</b>	<b>90</b>	<b>390</b>	<b>160</b>	<b>69</b>	<b>111</b>	<b>3735</b>	
	<b>TOTAL W/OPTIONAL TASK (TASKS 1-5)</b>	<b>14</b>	<b>314</b>	<b>214</b>	<b>165</b>	<b>237</b>	<b>170</b>	<b>114</b>	<b>12</b>	<b>98</b>	<b>488</b>	<b>8</b>	<b>45</b>	<b>132</b>	<b>153</b>	<b>176</b>	<b>152</b>	<b>168</b>	<b>87</b>	<b>95</b>	<b>120</b>	<b>91</b>	<b>90</b>	<b>390</b>	<b>160</b>	<b>69</b>	<b>111</b>	<b>3,873</b>	

A photograph of a water treatment facility with large blue tanks and machinery, overlaid with a semi-transparent blue filter. A vertical purple bar is on the left, and a horizontal purple bar is behind the 'APPENDIX F' text.

APPENDIX F

# Statements for Joint Venture, Public Works Requirement & Conflict of Interest

**Jacobs**

Challenging today.  
Reinventing tomorrow.

# APPENDIX F - STATEMENTS FOR JOINT VENTURE, PUBLIC WORKS REQUIREMENT, AND CONFLICT OF INTEREST

IRWD | East Irvine Zone 3 to 4 Pump Station Rehabilitation Project

## JOINT VENTURE/SUBCONSULTANT ARRANGEMENTS

Jacobs is submitting this proposal as the sole prime consultant. No joint venture is proposed, and Jacobs is not proposing any subcontract or subconsultant arrangements for this project. If any change to this approach becomes necessary during performance of the work, Jacobs understands that subcontracting or subconsulting would require IRWD's prior written approval.

## PUBLIC WORK REQUIREMENT

Jacobs understands that portions of the Project may be deemed "public work" under California law, including certain geotechnical, surveying, inspection, or similar services. Jacobs will comply with IRWD's public work requirements and, for any firm performing such work, will provide the firm name and applicable DIR registration number in the proposal. Jacobs will also verify that any applicable subconsultants or subcontractors performing public work maintain current DIR registration and comply with all associated statutory requirements for the duration of that work. The Jacobs DIR# is 1000057877.

## CONFLICT OF INTEREST STATEMENT

To the best of our knowledge, Jacobs is not aware of any personal or organizational conflict of interest prohibited by law related to this Project. Jacobs will comply with applicable conflict of interest requirements and will promptly disclose any actual or potential conflict identified during the course of the work.

PROJECT MANAGER

**Marielle Coquia, PE**

E: [Marielle.Coquia@jacobs.com](mailto:Marielle.Coquia@jacobs.com)

P: 949.224.7626

April 30, 2026

Brian Waite, P.E.  
Engineering Manager – Treatment & Conveyance  
Irvine Ranch Water District  
15600 Sand Canyon Avenue  
Irvine, CA 92618

## **Subject: Addendum to Proposal for Engineering Design Services for the East Irvine Zone 3 to 4 Pump Station Rehabilitation Project (PR 12565)**

Dear Mr. Waite:

Jacobs appreciates the opportunity to submit this Addendum to Jacobs' proposal to support Irvine Ranch Water District with engineering design services for the East Irvine Zone 3 to 4 Pump Station Rehabilitation Project.

### **We have provided clarifications to the following items:**

1. Your proposal outlines a comprehensive condition assessment approach, including TM-1 and coordination with O&M staff; however, your level of effort appears lower than anticipated. Can you walk us through your assumptions regarding the depth of field investigation, number of site visits, and staff hours allocated to fully evaluate all assets?
  - Condition assessment assumed to be non-invasive visual inspections and interviewing with Operations and Maintenance staff. No performance tests are assumed.
  - One (1) dedicated site visit assumed for the condition assessment. IRWD will remove the pumps and coordinate site safety procedures.
  - An Asset register, safety admin, loading system into ACES condition assessment tool, and preparation of Technical Memorandum which will report findings
  - Jacobs included an allowance to account for additional field investigation (2 visits assumed) if deemed necessary during the condition assessment. It also includes engineering efforts to incorporate potential rehabilitation work at the pump station, such as pump cans and the suction header. It is assumed that existing pump intake piping configuration and sizes do not require changes. The additional work will be performed upon approval by IRWD.
2. The preliminary design phase includes multiple technical memorandums (TM-1 through TM-5), hydraulic modeling, phasing analysis, and development of the PDR. Can you clarify how your proposed hours support these deliverables and whether any efficiencies or assumptions are driving the reduced level of effort compared to similar projects?
  - Jacobs included an allowance for considering unforeseen conditions as mentioned above as well as increased a level of effort for subject matter experts (SME) as part of QA/QC and constructability review at the milestone deliveries in PDR and Final Design phases.
  - As suggested by IRWD, Jacobs assumed greater efforts in the preliminary design phase (i.e., Task 2.0) and, therefore, reallocated a portion of the labor hours from the final design tasks to preliminary design.
3. The RFP requested an anticipated list of technical specifications, which doesn't appear to be included in your proposal. Can you clarify your assumptions for the level of effort associated with specification development, including how this effort is allocated between the preliminary and final design phases, and confirm that it is fully captured in your proposed fee?
  - IRWD's standard specifications (as included in the Construction Manual and Project Manual) to be evaluated and

modified for use in the Project. For project-specific specifications not included in IRWD standards, Jacobs will develop them as needed to deliver a complete and biddable design. We have attached a proposed list of Jacobs' Technical Specifications which was not included in the proposal. A portion of the increased level of effort accounts for additional QC in specifications to ensure compatibility and coordination of sections from different sources.

We have included an updated list of Scope Assumptions and revised Level of Effort Fee Estimate for your consideration and is attached to this letter. The updated service Fee is **\$896,569 without the optional task and \$938,942, with the optional task.**

We appreciate the opportunity to support IRWD and look forward to working closely with your Engineering and Operations teams. If you have any questions or need additional information, please contact Marielle Coquia, PE at 949.224.7626 or marielle.coquia@jacobs.com.

Sincerely,



**Marielle Coquia, PE**  
Project Manager  
marielle.coquia@jacobs.com  
949.224.7626



**Deanie Ding, PE**  
Design Manager  
deanie.ding@jacobs.com  
949.224.7805



**Rich Nagel, PE**  
Principal-in-Charge  
rich.nagel@jacobs.com  
213.228.8227

## Assumptions

- Maximum outage window limited to approximately 2 days per major tie-in.
- Major mechanical equipment replacement assumed unless condition assessment determines otherwise.
- No modifications to existing pump station inlet header system under the slab.
- **Condition assessment assumed to be non-invasive visual inspections and interviewing with Operations and Maintenance staff. No performance tests assumed.**
- **One (1) dedicated site visit assumed for the condition assessment. IRWD will remove the pumps and coordinate site safety procedures.**
- The existing hydraulic model in InfoWater is up-to-date and calibrated to represent existing distribution networks.
- Reuse of existing buried conduits at pump station pad.
- Pump motor starter replacement assumed constant speed control; no VFDs included unless directed.
- Canopy to include new lighting.
- No changes to existing solar PV system unless directed.
- No building structural modifications included beyond the addition of a new canopy and hatch improvements.
- Surge analysis performed at engineering modeling level; advanced CFD for transient modeling not included.
- Permit fees reimbursed per RFP allowance. IRWD will coordinate and provide topographic mapping services to support civil improvements related to canopy installation, perimeter fence installation, and concrete pads.
- Implementation and integration of security cameras not included.
- No changes to site grading or drainage system.
- Topographic map of current conditions will be provided in AutoCAD platform will be provided by IRWD. If additional or updated topographic data is required to complete designs, IRWD will coordinate and obtain current topographic mapping to provide to Jacobs.
- **Included an allowance to account for additional field investigation (2 visits assumed) if deemed necessary during the condition assessment. It also includes engineering efforts to incorporate potential rehabilitation work at the pump station, such as pump cans and the suction header. It is assumed that existing pump intake piping configuration and sizes do not require changes. The additional work will be performed upon approval by IRWD.**
- **IRWD's standard specifications (as included in the Construction Manual and Project Manual) to be evaluated and modified for use in the Project. For project-specific specifications not included in IRWD standards, Jacobs will develop them as needed to deliver a complete and biddable design.**
- Deliverables will be submitted in the formats specified in the RFP.
- Per the RFP, the scope of services extends through bid services and does not include engineering services during the construction phase. Jacobs can offer services during construction (SDC) to IRWD, which would typically include submittal/shop drawing review, responses to requests for information (RFIs), preparation of design change notices (DCNs) and preparation of record drawings. If desired, Jacobs can provide a scope and fee for these services based on further discussions with IRWD, if appropriate at this stage in the project.



# LIST OF SPECS

IRWD | East Irvine Zone 3 to 4 Pump Station Rehabilitation Project

NO.	SPECIFICATION TITLE	REMARKS
<b>DIVISION 01 - GENERAL REQUIREMENTS</b>		
01045	Existing Facilities	IRWD Standard
01130	Dewatering	IRWD Standard
01200	Requests for Information (RFI)	IRWD Standard
01300	Submittal Procedures	Jacobs Developed
01400	Preconstruction and Post Construction Conferences	IRWD Standard
01410	Construction Safety Procedures	IRWD Standard
01420	Confined Spaces	IRWD Standard
01430	Operation and Maintenance Data	Jacobs Developed
01440	Temporary Facilities and Controls	IRWD Standard
01510	Testing, Training, and Facility Startup	IRWD Standard
01520	Closeout Procedures	IRWD Standard
01640	Manufacturers' Services	Jacobs Developed
01611	Seismic Anchorage and Bracing	Jacobs Developed
01840	Basis of Measurement for Payment	IRWD Standard
<b>DIVISION 02 - SITEWORK</b>		
02220	Demolition	Jacobs Developed
02223	Trenching, Backfilling, and Compacting	IRWD Standard
02528	Concrete Curbs, Gutters, and Sidewalks	IRWD Standard
02578	Pavement Removal and Replacement	IRWD Standard
02821	Fences and Gates	Jacobs Developed
<b>DIVISION 03 - CONCRETE</b>		
01300	Concrete Formwork	IRWD Standard
03201	Concrete Reinforcement	IRWD Standard
03300	Cast-In-Place Concrete	IRWD Standard
03600	Grout	Jacobs Developed
<b>DIVISION 05 - METALS</b>		
05050	Welding	Jacobs Developed
05120	Structural Steel and Miscellaneous Metalwork	IRWD Standard
05310	Steel Decking	Jacobs Developed
05500	Metal Fabrications	Jacobs Developed
05519	Post-Installed Anchors	Jacobs Developed
<b>DIVISION 09 - FINISHES</b>		
09900	Painting and Coating	IRWD Standard
<b>DIVISION 11 - EQUIPMENT</b>		
11212	Vertical Turbine Pumps	Jacobs Developed
11371	Compressed Air Systems	Jacobs Developed
<b>DIVISION 13 - SPECIAL CONSTRUCTION</b>		
13210	Hydropneumatic Tank and Accessories	Jacobs Developed
<b>DIVISION 15 - MECHANICAL</b>		
15040	Interior Inspection for Cement-Mortar Line Steel Pipe	IRWD Standard
15041	Chlorination of Water Mains, Wells and Reservoirs	IRWD Standard
15042	Hydrostatic Testing of Pressure Pipelines	IRWD Standard
15051	Installation of Pressure Pipelines	IRWD Standard
15053	Carbon Steel Pipe and Fittings	IRWD Standard
15056	Ductile-Iron Pipe and Fittings	IRWD Standard

# LIST OF SPECS

IRWD | East Irvine Zone 3 to 4 Pump Station Rehabilitation Project

NO.	SPECIFICATION TITLE	REMARKS
<b>DIVISION 15 - MECHANICAL</b>		
15057	Copper Pipe and Fittings	IRWD Standard
15060	Piping Support Systems (Contractor-Designed)	Jacobs Developed
15064	PVC Pressure Pipe and Fittings	IRWD Standard
15089	Combination Air Release and Vacuum Relief Valves	IRWD Standard
15100	Manual Valves	IRWD Standard
15151	Facility Identification	IRWD Standard
15162	Flexible Pipe Couplings and Expansion Joints	IRWD Standard
15205	Process Piping Specialties	Jacobs Developed
15209	Surge Control System	Jacobs Developed
<b>DIVISION 16 - ELECTRICAL</b>		
16010	General Electrical Requirements	IRWD Stanadard
16051	Miscellaneous Electrical Devices	IRWD Stanadard
16110	Raceways, Pull Boxes, and Fittings	IRWD Stanadard
16120	Conductors and Cables	IRWD Stanadard
16135	Cabinets and Enclosures	IRWD Stanadard
16140	Switches and Receptacles	IRWD Stanadard
16220	Low-Voltage AC Induction Motors	Jacobs Developed
16288	Surge Protective Devices	Jacobs Developed
16400	Service and Distribution?	IRWD Stanadard
16440	Low-Voltage Motor Control	Jacobs Developed
16450	Grounding	IRWD Stanadard
16455	Switchboards	Jacobs Developed
16500	Lighting	Jacobs Developed
16900	Power Measurement and Control	Jacobs Developed
16950	Electrical Testing	IRWD Stanadard
<b>DIVISION 17 - INSTRUMENTATION</b>		
17000	General Instrumentation Control Requirements	IRWD Standard
	Supplement 01 PLC Input/Output List	IRWD Standard
	Supplement 02 Instrument List Summary	IRWD Standard
	Supplement 03 Control Strategies	Jacobs Developed
17110	Identification Tags	IRWD Standard
17402	Instrumentation and Control Components	Jacobs Developed

Note: This page is intentionally left blank.

May 26, 2026

Prepared by: N. Mwe / J. Moeder

Submitted by: K. Burton

Approved by: Paul A. Cook 

## ACTION CALENDAR

### SAN JOAQUIN DAM DRAINAGE IMPROVEMENTS BUDGET INCREASE AND CONSTRUCTION AWARD

#### SUMMARY:

IRWD's San Joaquin Reservoir stores approximately 3,000 acre-feet of recycled water. The dam drainage improvements include the construction of improvements on the three berms located on the face of the dam to reduce the amount of erosion from rain events.

Staff recommends that the Board:

- Authorize a budget increase in the amount of \$853,000, from \$1,914,000 to \$2,767,000; and
- Authorize the General Manager to execute a construction contract with Orion Construction Corporation in the amount of \$1,947,000 for the San Joaquin Dam Drainage Improvements project.

#### BACKGROUND:

The San Joaquin Reservoir dam was constructed in 1966 to store treated water for the Metropolitan Water District of Southern California (MWD). In 2004 IRWD acquired the reservoir from MWD for the purpose of storing recycled water.

The San Joaquin Reservoir dam is a zoned earth embankment dam with a random rock fill on the face of the dam. The face of the dam consists of three berm levels, each equipped with monitoring instrumentation that is regularly accessed. Portions of these benches on the dam face regularly experience erosion during significant rain events due to the large surface area and limited stormwater conveyance facilities to handle the flows. In the past two rainy seasons, staff completed multiple repairs to the embankment. This process is labor intensive, often requiring handwork; the repairs are typically temporary since future storms often erode the repaired area.

In 2024, IRWD contracted with JIG Consultants to provide engineering design services to establish long-term drainage improvements on the face of the dam. JIG completed the design of the drainage improvements, which includes re-grading the three berms, constructing v-ditches, and placing rip rap below the lowest berm. The drainage improvements will be implemented on the three berm levels on the face of dam as shown in Exhibit "A". The improvements also include replacement of severely corroded handrails and a ladder used to access the spillway outlet structure at the toe of the dam.

#### Construction Award:

Staff advertised the project for construction bids to a select list of 38 mechanical and pipeline contractors. The bid opening was held on April 28, 2026, with bids received from KEC

Engineering, Orion Construction Corporation, and T.E. Roberts, Inc. Orion Construction Corporation is the apparent low bidder with a bid amount of \$1,947,000. The engineer’s estimate is \$1,977,000. Orion Construction Corporation is currently constructing the Lake Forest Zone 4 El Toro Tank 1 & 2 Rehabilitation project and is qualified to construct this project. Orion Construction Corporation’s bid information is attached as Exhibit “B”, and a summary of the three bids received is provided in the table below.

<b>Bidder</b>	<b>Bid Amount</b>
Orion Construction Corporation	\$ 1,947,000
T.E. Roberts, Inc.	\$ 2,188,591
KEC Engineering	\$ 2,413,800
<i>Engineer’s Estimate</i>	<i>\$ 1,977,000</i>

Staff reviewed Orion Construction Corporation’s bid and has determined that it is responsive. Staff recommends that the Board authorize the General Manager to execute a construction contract with Orion Construction Corporation in the amount of \$1,947,000.

FISCAL IMPACTS:

The San Joaquin Dam Drainage Improvements, Project 13166, is included in the FY 2025-26 Capital Budget and will be funded through 100% regional recycled water funds. A budget increase is required to fund the construction and engineering support services during construction as shown in the table below.

Project No.	Current Budget	Addition <Reduction>	Total Budget
13166	\$1,914,000	\$853,000	\$2,767,000

ENVIRONMENTAL COMPLIANCE:

The project is exempt from the California Environmental Quality Act (CEQA) because the action involves the repair, maintenance, and minor alteration of existing public utility facilities and mechanical equipment involving no expansion of existing or former use, as authorized under the California Code of Regulations, Title 14, Division 6, Chapter 3, Section 15301 (Class 1 “Existing Facilities”). Class 1 exempts the operation, repair, maintenance, permitting, leasing, licensing, or minor alteration of existing public or private structures, facilities, mechanical equipment, or topographical features, involving negligible or no expansion of existing or former use, such as existing facilities of publicly owned utilities used to provide public utility services. A Notice of Exemption for the project will be filed with the Orange County Clerk Recorder.

COMMITTEE STATUS:

Construction awards are not routinely taken to Committee prior to submittal to the Board.

Action Calendar: San Joaquin Dam Drainage Improvements Budget Increase and Construction Award  
May 26, 2026  
Page 3

RECOMMENDATION:

THAT THE BOARD AUTHORIZE A BUDGET INCREASE FOR PROJECT 13166 IN THE AMOUNT OF \$853,000, FROM \$1,914,000 TO \$2,767,000, AND AUTHORIZE THE GENERAL MANAGER TO EXECUTE A CONSTRUCTION CONTRACT WITH ORION CONSTRUCTION CORPORATION IN THE AMOUNT OF \$1,947,000 FOR THE SAN JOAQUIN DAM DRAINAGE IMPROVEMENTS, PROJECT 13166.

LIST OF EXHIBITS:

Exhibit "A" – Location Map  
Exhibit "B" – Bid Results

Note: This page is intentionally left blank.



Note: This page is intentionally left blank.

# Exhibit "B"

Irvine Ranch Water District  
San Joaquin Dam Drainage Improvements (13166), bidding on 04/28/2026 2:00 PM (PDT)

Printed 04/28/2026

## SAN JOAQUIN DAM DRAINAGE IMPROVEMENTS BID RESULTS

### Submission

#### Bidder Details

**Vendor Name** Orion Construction Corporation  
**Address** 2185 La Mirada Dr  
Vista, California 92081  
United States  
**Respondee** Mark Dowsing  
**Respondee Title** President  
**Phone** 760-597-9660  
**Email** estimating@orionconstruction.com  
**Vendor Type** CADIR  
**License #** 549309  
**CADIR** 1000010760

#### Submission Detail

**Submission Format** Electronic  
**Submitted** 04/28/2026 12:51 PM (PDT)  
**Delivery Method**  
Responsive  
**Submission Status** Submitted  
**Confirmation #** 483501

#### Respondee Comment

#### Buyer Comment

#### Attachments

File Title	File Name	File Type
Bid Forms.pdf	Bid Forms.pdf	Bid Form
CARB Certificates.pdf	CARB Certificates.pdf	CARB Certificate(s)

#### Subcontractors

Showing 1 Subcontractor

Name & Address	Desc	License Num	CADIR	Amount	Type
Southwest V-Ditch, Inc. 3625 Placentia Lane Riverside, California 92501	Flatwork	569779	1000004410	\$197,890.00	CADIR

### Line Items

Discount Terms No Discount

Item #	Item Code	Type	Item Description	UOM	QTY	Unit Price	Line Total	Response	Comment
<b>BASE BID ITEMS</b>							<b>\$1,947,000.00</b>		
1			Mobilization/Demobilization	LS	1	\$70,640.00	\$70,640.00	Yes	
2			Erosion Control Measures During Construction	LS	1	\$43,000.00	\$43,000.00	Yes	
3			Clearing and Grubbing, Site Demolition, and Soil Preparation	LS	1	\$78,000.00	\$78,000.00	Yes	
4			Miscellaneous Earthwork and Grading	LS	1	\$436,000.00	\$436,000.00	Yes	
5			Decomposed Granite Access Roads	SF	20900	\$9.00	\$188,100.00	Yes	
6			Modified Concrete Curbs and Gutters	LF	1480	\$177.00	\$261,960.00	Yes	
7			Concrete V-Ditch	LF	140	\$160.00	\$22,400.00	Yes	
8			Concrete Terrace Drain Ditches	LF	115	\$160.00	\$18,400.00	Yes	
9			U-Channel with Surface Grates and Transition Structures	LS	1	\$65,000.00	\$65,000.00	Yes	
10			Riprap and Rock Lining of Embankment	TON	2500	\$253.00	\$632,500.00	Yes	
11			Protect in Place Existing Settlement Markers and Construct Box and Cover	EA	1	\$10,000.00	\$10,000.00	Yes	
12			Demolish Existing and Replace Settlement Markers	EA	6	\$2,000.00	\$12,000.00	Yes	
13			Demolish Existing and Reconstruct Weir Box at Berm 1	LS	1	\$24,000.00	\$24,000.00	Yes	
14			Remove and Replace Handrails and Ladder at Existing Spillway Structure	LS	1	\$80,000.00	\$80,000.00	Yes	
15			Final Record Drawings	LS	1	\$5,000.00	\$5,000.00	Yes	
<b>ADDITIVE AND DEDUCTIVE BID ITEMS</b>							<b>\$0.00</b>		
16			ADDITION (+) OR DEDUCTION (-)	LS	1	\$0.00	\$0.00	Yes	

### Line Item Subtotals

Section Title	Line Total
BASE BID ITEMS	\$1,947,000.00
ADDITIVE AND DEDUCTIVE BID ITEMS	\$0.00
<b>Grand Total</b>	<b>\$1,947,000.00</b>