

Natural
Treatment
Systems

Irvine Ranch Water District

NATURAL TREATMENT SYSTEM

Design Guidelines



NATURAL TREATMENT SYSTEMS DESIGN GUIDELINES



November 2005

FOREWORD TO THE INTERNET PUBLICATION

June 2007

Irvine Ranch Water District (IRWD) is pleased to present our Natural Treatment Systems (NTS) Design Guidelines.

We are in the process of developing a watershed-wide system of constructed wetlands to treat existing and new urban runoff within the 130-square-mile San Diego Creek Watershed, in central Orange County, California. We developed a Master Plan that contemplated 31 wetlands that would reduce pollution entering Upper Newport Bay, one of the last remaining natural estuaries along the Southern California coast, from the tributaries of San Diego Creek. In the time since the Master Plan was completed, we have added more wetlands to treat urban runoff in neighboring watersheds; the count is now up to 40 wetlands.

As we began working with multiple consultants on design of the first wetlands to be constructed and donated by land developers, it became evident that a set of informal guidelines were needed. These informal guidelines provide standardization of the basic wetland components: inlet/outlet structures, access roads, fencing details, preferred plant materials, irrigation equipment for surrounding landscaping, and performance standards for vegetation establishment. Each wetland has its own character and design, but we hope the standardization will help maintain cost effectiveness and facilitate efficiency in their operation and maintenance.

Since we have had many inquiries from others regarding our wetland designs, we are publishing these guidelines on our website, www.naturaltreatmentsystem.org. We invite you to use the guidelines for your own purposes, whether it is a school assignment, stormwater project, or backyard pond. With that said, we need to clarify that we are in no way liable or responsible for their use or misuse, no matter what the project or purpose.

We also invite suggestions on how we can improve our guidelines. You can contact us through the website with suggestions.

Norris Brandt, PE
Environmental Quality Manager

Randy Sundberg, PE
NTS Engineer

ACKNOWLEDGEMENTS

The 1st edition for these Natural Treatment System (NTS) guidelines was created out of the plan check discussions regarding the initial NTS projects for the Irvine Community Development Company's Quail Hill and Turtle Ridge developments. The efforts of the following people have been instrumental in the creation of this living document of NTS design:

IRWD Staff

Norris Brandt, Environmental Quality Manager, IRWD
Lou Denger, San Joaquin Marsh Manager, IRWD
Gabriel Vargas, Recycled Water Irrigation Inspector
Chris Lum, Electrical Engineering Section
Dale Skidmore, Facility Maintenance
Jim Hyde, Regulatory Compliance
Al Dyson, Development Services
Mike Jack, Chief Inspector
Randy Sundberg, CE

Guideline Consultant

Stephen Dopudja, TRC
Camilla Khan TRC
Rose Moreno, TRC

ICDC Developments

Jamie Yoshida, ICDC

Quail Hill, PA – 17 NTS Basins

Mohammad Heiat, CE, Van Dell and Associates
John Hix, CE, Van Dell and Associates
John Wolter, CE, Van Dell and Associates
Stephanie Pankiewicz LSA, SWA

Turtle Ridge, PA 27 NTS Basin

Bill Martin, ICDC
Steve Chiu CE, The Keith Company
Kevin Kennedy, LSA, EDAW
Trent Noll, LSA, EDAW

Disclaimer

The Natural Treatment Systems Design Guidelines (“Guidelines”) are published by Irvine Ranch Water District on the following basis:

1. The District is not responsible for the consequences of any action taken in reliance upon information in the Guidelines.
2. The District is also not responsible for any errors or omissions in or from the Guidelines.
3. The District disclaims all and any liability to any person in respect to anything and the consequences of anything done or omitted to be done by a person in reliance upon the whole or any part of these Guidelines.
4. The Guidelines do not assert or purport to be a comprehensive statement and analysis of their subject matter.
5. The Guidelines do not assert or imply that the information is complete, accurate, or current.
6. The services of a suitably qualified person should be sought before action is taken in any particular case.

TABLE OF CONTENTS

	<u>PAGE NO.</u>
1.0 INTRODUCTION	1
2.0 REGIONAL WATER QUALITY CONTROL BOARD (RWQCB) REGULATIONS	1
2.1 General Stormwater Regulations	1
2.2 Total Maximum Daily Load (TMDL) Limits	2
3.0 DESIGN SUMMARY	2
Figure 1 - Typical NTS Components and Design	4
Figure 2 – Typical Cross-Section of a NTS, Vegetation and Irrigation Zones	5
3.1 System Layout	6
3.2 General Design Parameters	8
4.0 CIVIL AND LANDSCAPING DESIGN DETAILS	9
4.1 Standard Notes	9
4.2 Construction Details	10
4.2.1 Access Roads	11
4.2.2 Isolation Structures and Gates	12
4.3 Monitoring Facilities and Electrical Service	12
5.0 PLAN CHECK SUBMITTALS, GRADING AND LANDSCAPE PLANS	13
6.0 LANDSCAPING AND PLANTING	13
6.1 General Landscaping Design	13
6.2 General Plant Material Guidelines	14
6.3 Site Preparation	14
6.3.1 Trash and Debris Removal	14
6.3.2 Soil Condition and Preparation	15
6.3.3 Weed Eradication	15
6.3.4 Herbicide Treatment	17
6.3.5 Erosion Control	18
6.3.6 Materials	18

TABLE OF CONTENTS
(Continued)

PAGE NO.

6.4	Planting Methods	20
6.4.1	Container Plants/Willow and Mulefat Cuttings	20
6.4.1.1	Willow and Mulefat Cuttings	21
6.4.2	Hand Seeding	22
6.4.3	Hydroseeding	22
6.5	Wetland Vegetation	23
6.6	Riparian Vegetation (LWL to HWL)	24
6.7	Upland/Transition Zone (HWL to Edge of Access Road)	25
6.8	Planting Densities	26
6.9	Soils and Substrate	26
7.0	IRRIGATION	27
7.1	General	27
7.2	System Criteria	27
7.3	Equipment List	28
7.4	California Regional Water Quality Control Board, Santa Ana Notification	29
8.0	PERFORMANCE MONITORING	29
8.1	Landscape Monitoring and Acceptance Criteria	29
8.2	Performance Monitoring	29
8.3	Landscape Maintenance	30
8.3.1	Maintenance of Landscape	30
8.3.2	Replacement of Vegetation	30
8.3.3	Removal of Invasive Vegetation	31
8.3.3.1	Methods of Removal	31
8.3.3.2	Herbicide Treatment Guidelines	33
8.3.4	General Shrub Care	34
8.3.5	General Tree Care	34
8.3.6	Disturbance Concerns	34
8.4	Pest Control	35
8.5	Irrigation	35
9.0	SECURITY AND SIGNAGE	35
10.0	PERMITS	36

TABLE OF CONTENTS
(Continued)

PAGE NO.

11.0 PROPERTY ACCESS AND EASEMENTS 37

12.0 DELIVERABLES 37

13.0 INSEPCTION 37

Appendix A NTS O&M Manual Information Checklist and Outline

NTS Guideline Drawings

- NTS – 1 Dry Weather Flow-Small Sediment Basin
- NTS – 2 Level Control Outlet Structure
- NTS – 3 Intermediate Berm Level Control Structure
- NTS – 4 Post and Cable Fence

NATURAL TREATMENT SYSTEMS DESIGN GUIDELINE

1.0 INTRODUCTION

1. The IRWD, in cooperation with the County of Orange and various cities within the San Diego Creek watershed, is developing an ecosystem-based network of constructed water quality treatment wetlands, known as natural treatment systems (NTS). NTS are designed and constructed to improve water quality by taking advantage of processes that occur in natural wetlands. The NTS is an additional layer of treatment on top of the first flush best management practice (BMP) required by the City and County per the MS4 permit of the California Regional Water Quality Control Board (CRWQCB). Design review of first flush BMP's are the responsibility of the City or County. Each development, or local, NTS constructed is a portion of a larger regional approach to dealing with non point source pollution. Specific goals in the design of natural treatment systems include:
(1) improvement of water quality in the San Diego Creek watershed and other watersheds partially or completely within District boundaries and (2) the reduction of Total Maximum Daily Loads (TMDLs) of various constituents discharged to Upper Newport Bay. The reduction of TMDLs is required to meet targets established under the Municipal Separate Storm Sewer System (MS4) Permit issued to Orange County and a number of Cities or co-permittees. Design criteria for natural treatment systems have been developed to achieve these goals and are outlined in the following sections.

2.0 REGIONAL WATER QUALITY CONTROL BOARD (RWQCB) REGULATIONS

2.1 GENERAL STORMWATER REGULATIONS

1. As authorized by the Clean Water Act (CWA), the National Pollutant Discharge Elimination System (NPDES) permit program controls water pollution by regulating point sources that discharge pollutants into waters of the United States. Under the NPDES storm water program, operators of large, medium and regulated small municipal separate storm sewer systems (MS4s) require authorization to discharge pollutants under an NPDES permit.

2. Treatment of urban runoff by natural treatment systems will assist the County of Orange and permitted cities in meeting their discharge requirements under the MS4 permit. The IRWD is not a co-permittee under the MS4 permit; however, the District has assumed maintenance and monitoring responsibilities for the natural treatment system, in cooperation with the responsible parties.

2.2 TOTAL MAXIMUM DAILY LOAD (TMDL) LIMITS

1. The MS4 permit, issued by the California Regional Water Quality Control Board, Santa Ana Region, specifies TMDLs for sediment and nutrients in San Diego Creek and Newport Bay. TMDLs for Newport Bay for several toxic pollutants which are exceeding applicable State water quality standards: selenium; several heavy metals; and several organic chemicals including modern pesticides (i.e., diazinon and chlorpyrifos) and legacy pesticides (DDT, Chlordane, etc.) and polychlorinated biphenyls (PCBs).
2. Each NTS facility will need to be designed to reduce TMDLs of these pollutants. The Natural Treatment System Master Plan identifies the estimated pollutant removal for each site. The developer shall verify any changes to the Master Plan for the local natural treatment system facilities.
3. Monitoring of water quality will allow the IRWD to determine if the natural treatment system is removing pollutants as designed.

3.0 DESIGN SUMMARY

1. Natural treatment systems reduce pollutants in stormwater through the processes of sedimentation, filtration, solar ultraviolet disinfection, nitrification, plant uptake, and volatilization. Figure 1 indicates the main components of a typical natural treatment system and the processes that occur as stormwater runoff flows through each component. Figure 2 illustrates the various vegetation and irrigation zones of a typical system cross-section. Properly designed and operated natural treatment system facilities can reduce the TMDLs of various pollutants that would otherwise be discharged to the receiving water body. Natural treatment systems will be provided by developers to treat the urban runoff within their

development and reduce TMDLs for various pollutants, such as, but not limited to: sediment, nitrogen, phosphorous, pathogens, pesticides, selenium and heavy metals.

2. Natural treatment systems can be categorized into three main types, based on their location in relation to stream channels and detention basins:
 - (1) Type I – Off-line facilities: Designed to treat low flows that are diverted into an off-line wetland facility.
 - (2) Type II – In-line facilities: Designed to create water quality treatment wetlands within existing stream channels.
 - (3) Type III – Combination facilities: Designed to incorporate natural treatment systems into existing flood control basins.

3. Most of the Development/Local facilities will be Type I or III, under the management of various jurisdictions (County or City Flood Control, County Vector Control, IRWD NTS maintenance and operation). The primary purpose of the Development/Local facilities will be treatment of base flows from urban development.

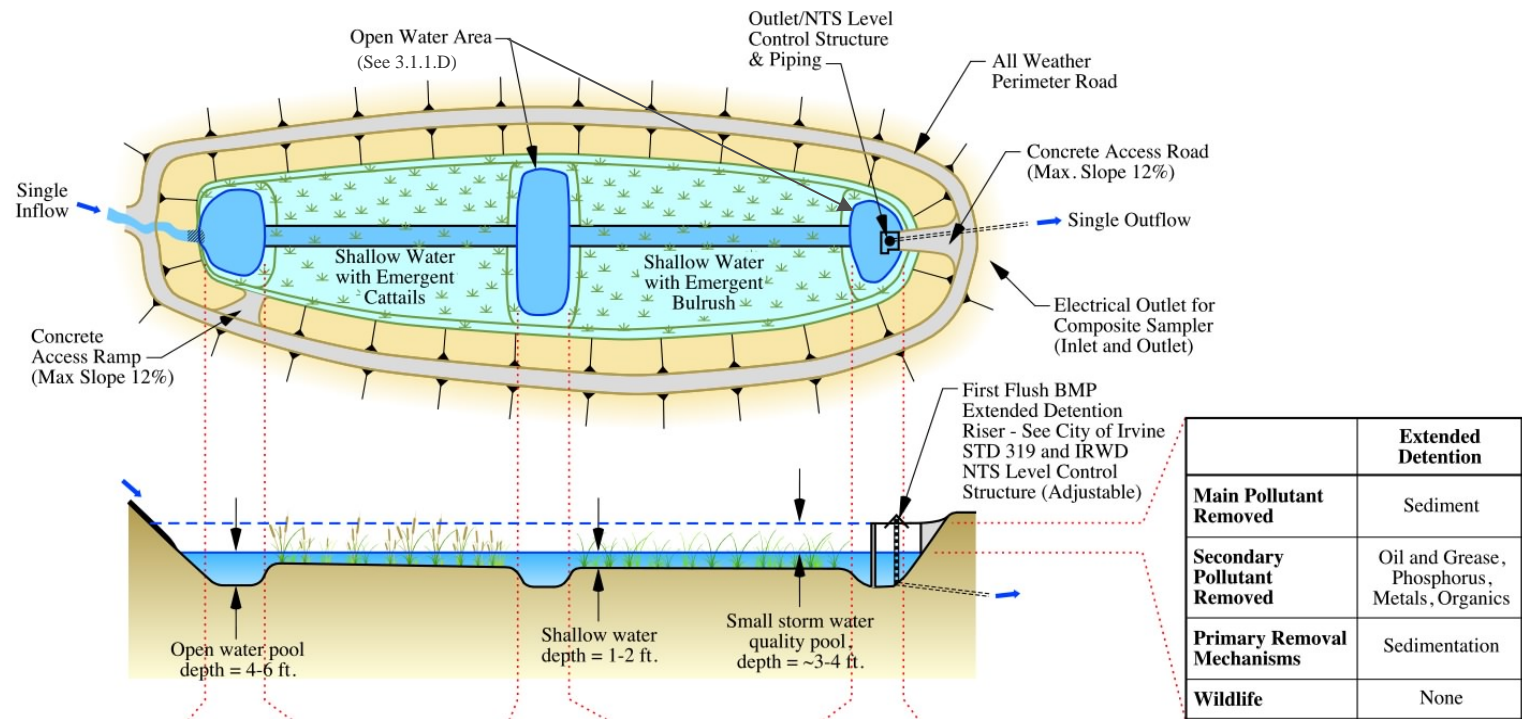

	Inlet Pool	Cattail Stand	Open Water Pool	Bulrush Stand	Outlet Pool
Main Pollutant Removed	Sediment, Pathogens	Nitrate, Phosphorus, Metals, Pathogens	Pathogens, Organic Transformation	Organics, Pesticides	Pathogens
Secondary Pollutant Removed	Phosphorus, Metals, Organics	Organics	Sediment	Nitrate, Phosphorus, Metals	Organics
Primary Removal Mechanisms	Sedimentation, UV Solar Radiation	Nitrification, Plant Uptake, Filtration, Sedimentation	UV Solar Radiation, Volatilization	Nitrification, Plant Uptake, Sedimentation	UV Solar Radiation
Wildlife	Mosquito Fish, Birds	Birds, Insect Larvae e.g., Dragonflies, Mosquito Fish	Ducks, Mosquito Fish	Birds, Insect Larvae e.g., Dragonflies, Mosquito Fish	Ducks, Mosquito Fish

Figure 1 Typical Natural Treatment System Components and Design

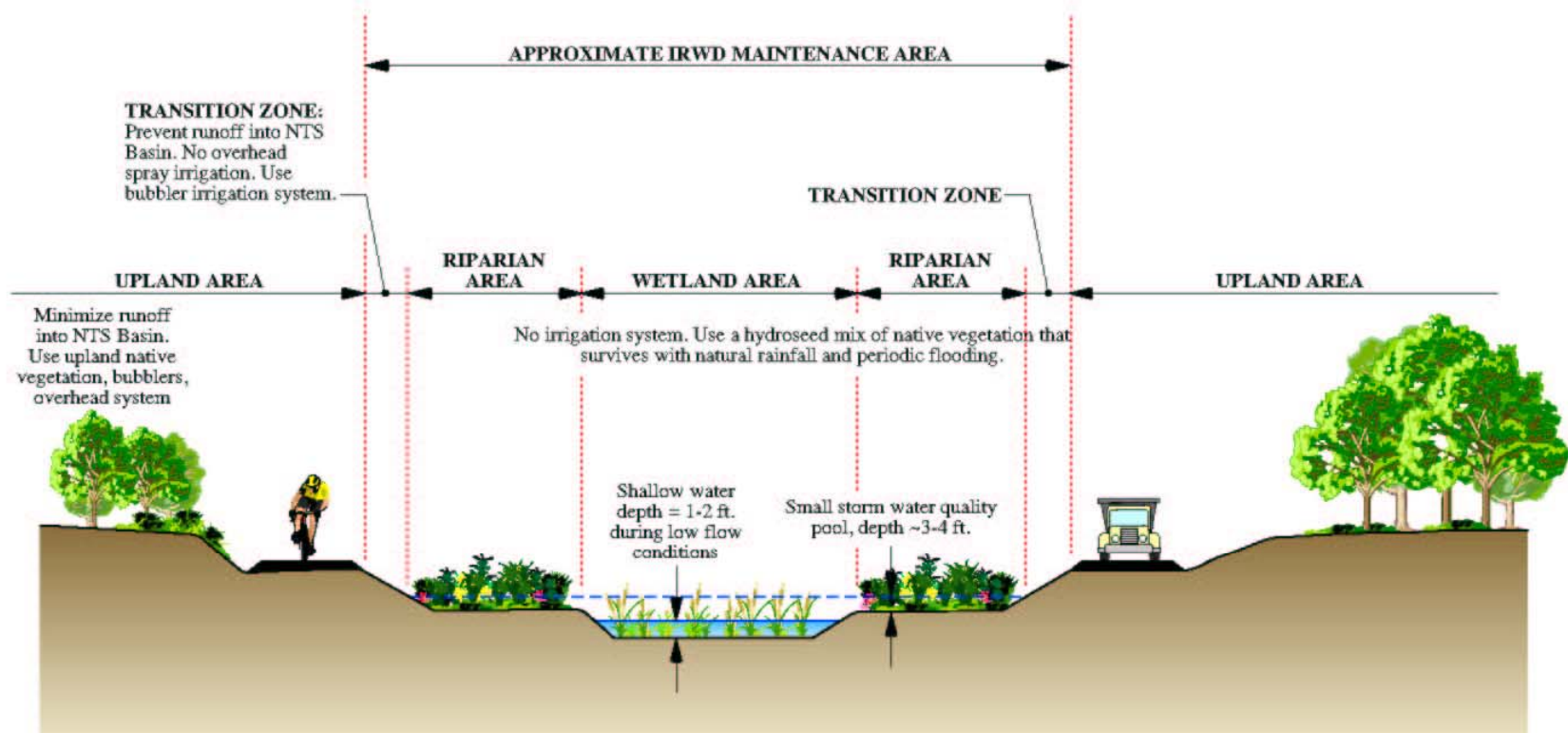

Figure 2 Typical Cross-Section of a Natural Treatment System Showing Vegetation and Irrigation Zones

3.1 SYSTEM LAYOUT

1. Natural treatment systems incorporate various elements to achieve specific design objectives. While each wetland design will be tailored to local conditions and constraints, most of the natural treatment system facilities share common design features, as shown in Figure 1 and the NTS Master Plan. These design elements are intended to provide various functions within the natural treatment system, as follows:

- A. Inlet Structures

Inlet structures will be designed to dissipate energy at the inflow, which will reduce the potential for erosion and damage to wetland plants. If riprap is used, it shall be grouted to discourage vector breeding areas. Inlet structures also spread the water laterally and help prevent short-circuiting of flows through the treatment facility. The number of inlets to the inlet pool shall be limited to a single feed to facilitate water quality monitoring requirements. The inlet shall be placed a minimum of one foot above the basin's general invert elevation in an effort to prevent blockage of the storm drain conduit by silt build up. An isolation sluice gate structure, or other means to contain and drain the system, shall be required in the event of a hazardous material spill.

- B. Inlet Pool

The inlet pool is designed to trap the majority of coarse sediments in the inflow. They shall also promote easy desilting and trash removal. Vector control may be achieved through the use of Mosquito fish. Any riprap should be grouted to discourage mosquito reproduction.

- C. Shallow Water with Emergent Cattails

Shallow water, 1-2 feet in depth, supports emergent plants such as cattails, which provide frictional resistance to slow the velocity of the inlet waters, promoting sedimentation and increasing the time for pollutant removal. Cattails are aggressive emergent plants that are effective in facilitating microbially-mediated removal of nitrate and immobilization of heavy metals and metalloids such as selenium. Cattails also provide a good physical substrate for filtering bacteria, and some removal of soluble phosphate. Cattails are selected for planting in upstream areas near the inlets because they are not an attractive food source for native fish and waterfowl.

- D. Open Water Areas

Deeper, open water areas, approximately four to six feet deep, provide favorable environments for mosquito fish and also provide sites for ultraviolet degradation of complex organics and pathogens. Open water areas also provide access areas for mosquito control measures. Open water pools may be required for basins with tributary drainage areas of greater than 100 acres.

- E. Shallow Water with Emergent Bulrush

Bulrushes also help to slow the velocity of inlet flows, promoting sedimentation and increasing retention time for pollutant removal. Bulrushes provide a good long-lasting

peat source for anoxic degradation of organic pollutants such as pesticides and petroleum products.

F. Outlet Structures

Outlet structures control the hydraulic regime of the wetlands. A level control structure shall be incorporated into the outlet structure to provide precise level controls. Aluminum stop logs shall be limited to a maximum width of 48-inches. The number of outlets from the wetlands shall be limited to a single facility to facilitate water quality monitoring requirements. Extended detention riser outlet structures will be employed in the proposed wetlands because they drain water more slowly than culverts. Erosion control will be provided at the inlet and outlet ends and a device to prevent floating debris from clogging the outlet may be installed on the perforated riser. Outflow structures will be equipped with valves or gates to permit drainage of the wetland pool for operation and maintenance purposes. A trash rack on the outlet will prevent plugging with debris and provide safety to the public.

An isolation sluice gate structure, or other means to contain and drain the system, shall be required in the event of a hazardous material spill.

G. Riparian and Upland Vegetation

Vegetation in the riparian area adjacent to the wetlands can serve important habitat functions, including:

- (1) produce detritus, a critical foundation of the wetland food chain;
- (2) provide shading, which helps control water temperature; and
- (3) provide a transition between the wetlands and the surrounding habitat. Upland vegetation will serve as a buffer between the natural treatment system wetlands and the surrounding urban uses.

Figure 2 is a cross-section of a typical natural treatment system showing the transitions between the riparian and upland areas.

H. Plug-Flow Configuration

The natural treatment systems are designed to be a linear channel-like configuration in order to promote “plug flow”. Plug flow refers to the concept that water entering the wetlands moves as a unit from the inlet to outlet, promoting uniform flow, which improves treatment effectiveness. Alignment of the basin shall be in the direction of the prevailing wind to discourage mosquito reproduction

I. Monitoring Equipment

Monitoring devices for automatic flow measurement and water quality sampling will be installed near the inlets and outlets to measure influent and effluent pollutant concentrations. Electrical outlets shall be provided at each inlet and outlet above the HWL, but not more than 15 feet above the sample point and 35 feet horizontally.

3.2 GENERAL DESIGN PARAMETERS

1. Design considerations will vary depending on the location and shall conform with Table 7.2 of the Natural Treatment System Master Plan and the particular objectives of the stormwater treatment plan. Common design parameters that need to be considered in the natural treatment system design are as follows:

- A. Depth of water: Water depths along the channels and in wetland and ponded areas are varied, as shown in Figure 1 and 2, to provide a variety of treatment functions and habitats. Specifically, vegetation communities consist of emergent, aquatic, and woody plants, which have different preferred water depths depending on both the type of plant and specific plant species.
- B. Detention time: Many natural treatment facilities are designed with a dual function of treating low flows and stormwater runoff from small storms as well as the first flush of large storms. The developer/local natural treatment system facilities are designed primarily for the treatment of low flows.

Stormwater detention in Type I off-line facilities occurs through use of levees constructed around the perimeter of the wetlands, as shown in Figure 1. In this figure, the area for stormwater detention is the same as the wetland area. However, at many sites, the area available for stormwater detention is greater than the area of the wetlands. The levees are designed to provide a stormwater quality pool depth of about 3-4 feet above the water level in the wetlands. Optimum treatment of low flows requires a detention period of 10 to 14 days, with 10 days considered to be a minimum. During periods of stormwater detention, the wetlands will be mostly inundated for a period of about 36-48 hours as required by other agencies per the Regional Boards MS4 permit.

Type II in-line facilities are intended for treatment of low flows so there is no stormwater detention component.

At Type III facilities, stormwater detention is integrated with the flood retarding function of the facility so no additional levees are anticipated to be needed at these sites.

- C. High Runoff flows: Runoff from large storm events can potentially stir up and move sediments that were previously settled and can potentially damage wetland vegetation. Diversion structures at the Type I offline facilities are designed to bypass flows in excess of the storage capacity of the stormwater quality pool.

- D. Trash and Coarse Sediments

Design of sediment traps in the inlet pool will consider likely upstream sediment sources. Trash racks will be installed upstream of the wetlands to capture large trash and vegetative debris.

- E. Channel Banks

To address water safety concerns, the wetlands are designed with shallow side slopes along the perimeter, generally between 3:1 and 5:1. Type II in-line facilities are intended to create shallow water pools within existing stream channels so sloughing and

failure of side slopes caused by increased wetting should not generally be a concern. However, riprap may be placed along the base of the channel wall for increased protection.

F. Channel Profile

The profile of the wetland will be designed with a gradual slope to keep the water velocity low, which promotes more effective treatment in the wetlands and limits stress on the vegetation that could be caused by high water velocities. However, design slopes will not be so low that stagnant water conditions exist, which could promote mosquito breeding or other nuisances.

4.0 CIVIL AND LANDSCAPING DESIGN DETAILS

4.1 STANDARD NOTES

1. Standard notes shall include the following:

IRWD GENERAL NTS NOTES

- “This NTS corresponds to recommendations of the NTS Master Plan, identified as Local Site No. _____. “ (See Tables 3.2; 7.2 and Appendix A of the NTS Master Plan for Site Number)
- “Construction of natural treatment systems shall be performed in accordance with the Procedural Guidelines, The NTS Design Guideline, the IRWD Construction Manual and local codes.”
- The Contractor shall have a copy of the IRWD Construction Manual, the signed approved plans and specifications on site at all times.
- The IRWD inspection representative shall be notified at least two working days prior to the pre-construction meeting and 4 days prior to start of construction and of any required observation. No facility shall be backfilled until Inspected by IRWD. Standard working hours for IRWD inspection / operations personnel are 7:00 am to 3 pm Monday through Friday, excluding holidays
- The contractor shall maintain the work area in a neat, safe, clean and sanitary condition at all times and to the satisfaction of the agency having jurisdiction over the area. Working area shall be kept Clean of Debris, dust and other nuisances being controlled at all times. The Contractor shall be responsible for any clean up on adjacent streets affected by their construction. The Contractor shall be responsible for submitting and obtaining a Storm Water Pollution Prevention Program from the Regional Water Quality Control Board.

2. Submittal notes shall include the following:

SUBMITTALS NOTES

- A. The following note shall be placed under the IRWD standard notes on all NTS grading plans:

- The contractor shall submit shop drawings, cut sheets and specifications of the proposed equipment for the NTS level control structure and any isolation gate structure(s) and any other IRWD maintained item for the NTS facility to the developer/ engineer and obtain approvals from the engineer and IRWD prior to ordering any specialized material or equipment.

- B. The following note shall be placed under the IRWD standard notes on all NTS landscaping plans:

- The contractor shall submit seed mix, mulch, plant palette, certification of native origins and shop drawings, cut sheets and specifications of any other IRWD maintained item, such as but not limited to, electrical, flow sampler, communications and sprinkler system for the NTS facility to the developer/ engineer and obtain approvals from the engineer and IRWD prior to ordering any specialized material or equipment.

3. The following disclaimer shall be placed in the vicinity of the IRWD signature block (See Procedural Guidelines, Chapter on NTS) The IRWD signature block shall also include the plan check code:

IRWD DISCLAIMER NOTE

- The Irvine Ranch Water District's approval is limited to the operation, maintenance and monitoring of the natural treatment facility as a service to the County or governing City and does not govern flood control or enforcement of the water quality objectives as set by the responsible agency. The responsibility for the design of the natural treatment facility rests solely with the developer for providing the capacity and treatment of pollutants as generated by the proposed urban development to the satisfaction of the County or governing City as permitted by the California Regional Water Quality Control Board.

4.2 CONSTRUCTION DETAILS

1. Design documents shall include grading and landscape construction drawings and technical specifications that address, but not limited to, the following:
 - A. Existing site conditions
 - B. Excavation Limits
 - C. Location of Benchmark

- D. Proposed Structures
- E. Channel plan and profile
- F. High flow and low flow hydraulic grade line
- G. Types of materials i.e., concrete, pipe, backfill, liner, vegetation, etc.
- H. Types of equipment i.e., pumps, valves, control panel, irrigation, etc.
- I. Details of inlet, outlet, control structures and trash containment
- J. Access and staging areas
- K. Electrical service
- L. Security and signage.
- M. Vector control (Mosquitoes)
- N. Show City, County and IRWD maintenance limits, such as cross hatched, detail or other
- O. Provide isolation sluice gate structures, or other to contain hazardous spills
- P. Grading requirements per applicable codes (IRWD, Greenbook, City, County, etc.)
- Q. Subgrade for structures per IRWD Construction Manual
- R. Concrete work requirements

4.2.1 ACCESS ROADS

1. Access ramps into the NTS Basin shall be a minimum width of 12' and shall be concrete with reinforcement and class II aggregate base structural section as recommended by the Engineer. Concrete color shall be Desert Sand, unless otherwise specified by the Engineer and approved by IRWD. The structural section shall be at least 6" of concrete on 4" class II aggregate base. Maximum longitudinal slope shall not exceed 10% and slopes over 8% shall have a horizontal raked finish.
2. Access roads to, and perimeter patrol roads around, the NTS basin shall be a minimum width of 14' with 3' shoulders and shall provide all weather access with a structural section as recommend by the Engineer.

The Engineer shall design the access and perimeter roads to account for dead parking areas in front of access gates, minimum turning radius and grade breaks for dump trucks pulling low boy trailers with back hoes and/or vactor trucks (minimum turning radius of at least 50').

Access roads with a longitudinal slope of 0% - 8% shall have a structural section of at least 4" of AC on 8" of class II aggregate base. Access roads with a longitudinal slope of 8%-10% shall have a structural section of at least 6" of concrete on 4" of class II aggregate base with a raked finish and reinforcement as recommended by the Engineer. Access roads shall have a cross slope of at least 2%.

The portion of the perimeter patrol road around the NTS basin that also doubles as an access road to the outlet and inlet structures shall be at least 4" of AC on 8" of class II aggregate base. The remaining section of the perimeter patrol road around the NTS basin maybe a class II aggregate base all weather road as recommended by the Engineer if the

longitudinal slope is between 0% - 4%. Perimeter patrol roads of AC shall have a cross slope of at least 2%. Perimeter patrol roads of class II aggregate base shall have a maximum cross slope of 2% and sheet flow shall be limited to that generated by the roadway width and any adjacent landscaped slope to a maximum of 3' in height.

3. The Engineer shall submit to IRWD all supportive calculations and geotechnical information regarding the structural sections of the access roads.

The Engineer shall direct the Contractor to provide submittals and obtain approvals by the Developer/ Engineer and IRWD prior to the contractor ordering access road materials.

4.2.2 ISOLATION STRUCTURES AND GATES

1. An isolation sluice gate structure, or other means to contain and drain the system, is required in the event a hazardous material spill occurs upstream of the NTS Basin. The Engineer shall provide detailed plans, notes and specifications to clearly show how to construct the isolation structures and gates. Isolation sluice gates shall be manufactured by H. Fontiane, Ltd or Waterman. The isolation sluice gate shall be 316 stainless steel and configured to keep the thrust ring out of the flow path as much as possible. The sluice gate shall be mounted within a structure that shall provide for safe and easy operation, maintenance and replacement. The sluice gate shall have a 2" square operating nut for valve key operation, or similar method that limits access of the sluice gate by non-IRWD personnel. The sluice gate shall be mounted to the structure with a wall thimble and stainless steel nuts, bolts and EPDM gaskets. No direct wall mounting is allowed due to the difficulty of getting this method to properly work. The Engineer shall require the Contractor to submit shop drawings and cut sheets for approval by the Developer/Engineer and IRWD prior to the contractor ordering equipment.

4.3 MONITORING FACILITIES AND ELECTRICAL SERVICE

1. Monitoring facilities for water quality of the natural treatment systems will be specified for each site, based on the Master Plan and review by District staff. Based on the treatment effectiveness for pollutant removal, the monitoring objectives may change over time. Thus, the facility must be designed to accommodate both automatic and manual monitoring devices. Samplers require a minimum of a 4 inch pool to draw from, and shall not be placed higher than 15 feet above the lowest sampling point or more than 35 feet horizontally from the sampling point. If a modified junction structure or MH is used for a sampling point the opening shall be at least a 30 inch diameter opening with a light weight fiberglass MH cover with stainless steel bolt downs as manufactured by Comcore Utility Products, Inc. MH steps shall be poly coated and conform to APWA Standard Plan 636-1 or approved equivalent. The junction structure's shaft inside diameter dimensions shall be modified to

conform to IRWD's Procedural Guidelines, Section 4, Extra Depth Requirements. Generally, electrical service must be available at both the inlet and outlet to the natural treatment system, to accommodate future requirements and for the irrigation controllers. For monitoring devices such as sampling units, a G.F.I. duplex receptacle with weatherproof jumbo cover along with a 5 foot x 5 foot x 6 inch concrete pad would be required. For each inlet and outlet the sample unit shall be a refrigerated liquid Sampler, Sigma 900Max All weather enclosure, with flow measurement capabilities, Sigma 950, with RS-232 connections and SCADA modbus communication protocol with optional modem. The primary flow measuring device, such as flume, pipe, channel or weir shall be design and installed to fit the hydraulic situation for each NTS basin.

2. The developer shall apply for, coordinate with and provide approved service plans from Edison and, if required, from the phone company. The developer shall also provide an electrical and telephone site plan from the utility Point-of-Connection (POC) to each sample point, irrigation controller and other miscellaneous designated outlet. The developer/engineer shall coordinate and meet with IRWD and the service planner prior to preparing the final design. At this time the developer/engineer shall work with IRWD in the investigation of the possibility of using radio communications at the NTS site in lieu of telephone service. However, radio communications are based on line-of-sight and the developer must provide information to IRWD that verifies that future planned developments will not block the radio signal from the NTS site to the existing IRWD radio antennas.

5.0 PLAN CHECK SUBMITTALS, GRADING AND LANDSCAPE PLANS

1. Refer to Chapter 6 of the Procedural Guidelines for submittal procedures requirements.

6.0 LANDSCAPING AND PLANTING

1. Natural treatment system wetlands will be landscaped according to facility type, adjacent land use, and type of natural habitat present. All vegetation will be native to the region to complement the natural diversity and attract native wildlife. A planting scheme of the proposed vegetative community shall be depicted on the natural treatment system site plans. Include the species, quantity, spacing of all plantings, stock type (bare root, plug, container, seed) and the source of the plant material. The plan must identify the proper time to plant

and include, if appropriate, acceptable substitutions. If bare root stock is being used, they should be planted in the spring.

6.1 GENERAL LANDSCAPING DESIGN

1. Plant material is an integral component to the design and function of natural treatment system wetlands. The preferred planting arrangement is flexible but should remain in a random or "natural plant layout". Massings and groupings of single species are generally preferred over linear arrangements and alternating patterns. While the design is flexible, it is important to establish distinct and diverse layers of overstory trees, understory trees, shrubs and herbaceous materials. The intent is to establish a diverse, dense vegetative cover to treat stormwater runoff, provide wildlife habitat, and withstand stresses from insect and disease infestations, drought, temperature, wind and exposure.

6.2 GENERAL PLANT MATERIAL GUIDELINES

1. The use of native plant material, combined with minimum planting area size, provides cover for wildlife and creates a microenvironment within the landscape. The conditions of a natural treatment system mimic natural wetland and floodplain areas. Typical plant species found in these natural settings should be obtained from local nurseries specializing in native plant propagation (generally, these materials are not available from commercial nurseries) and installed per IRWD standard specifications. Locally grown material, if available, is preferred over material purchased from another region, as it is more likely to be adapted to local conditions (i.e., soils, weather, hydrology, etc.). Material should be selected at the nursery by a qualified individual who will visually inspect trees and shrubs either at place of growth or onsite before planting for compliance with requirements for genus, species, variety, size and quality. In addition, seed should be purchased from a reputable supplier experienced in obtaining, processing and distributing viable native seed mixes. Avoid the use of weedy, invasive, or non-native species.

6.3 SITE PREPARATION

1. The site must be prepared for the installation of plant materials and the application of seed. The Contractor shall complete the following tasks.

6.3.1 TRASH AND DEBRIS REMOVAL

1. The facility shall be kept free of all trash and debris at all times. All trash and debris shall be removed from the site by the Contractor and legally disposed of offsite.

6.3.2 SOIL CONDITION AND PREPARATION

1. Soil Testing: Upon acceptance of the site, conduct soil testing program to verify the specified soil conditioning program.
 - a. The project area shall be divided into four areas, and composite soils samples collected and analyzed for each area.
 - b. Soils testing shall consist of a complete horticultural suitability analysis testing, including:
 1. Fertilize (pH, salinity, nitrate nitrogen, ammonium nitrogen, phosphate phosphorus, potassium, calcium magnesium and sodium).
 2. Agricultural suitability (saturation extract salinity, Sodium Alkalinity Ratio (SAR).
 3. Particle size appraisal (USDAA particle size).
 - c. Soils testing shall be accompanied by a written report by the testing laboratory, with recommendations for a modified soil conditioning program, if required.
 - d. Approved soils testing laboratories:
 1. Soil and Plant Lab, Inc., PO Box 6566, Orange, CA 92863-6566; Telephone: (714) 282-8777.
 2. Wallace Laboratories, 365 Coral Circle, El Segundo, CA 90245; Telephone: (310) 615-0116.
2. The soil shall be prepared in accordance with the recommendations provided in the soils report.

6.3.3 WEED ERADICATION

1. All weeds that are present shall be aggressively eradicated prior to and throughout the installation period, mechanically, if feasible. In circumstances where mechanical removal is

not effective, it is appropriate to utilize systemic herbicides that have been approved by the U.S. Environmental Protection Agency (EPA) for use in aquatic situations. All weeds shall be removed and all resulting debris shall be legally disposed of off site. The IRWD Biologist/Restoration Specialist shall inspect the site prior to seeding and plant installation to ensure that it is weed free. The Target species and those determined by the IRWD Biologist/Restoration Specialist to be inconsistent with the success of the site shall be removed. Targeted weed species include, but are not limited to, the following

- Mustard (*Hirschfeldia* spp. and *Brassica* spp.)
- Pampus grass (*Cortaderia selloana*)
- Bermuda grass (*Cynodon dactylon*)
- Hottentot-fig (*Carpobrotus edulis*)
- Garland chrysanthemum (*Chrysanthemum coronarium*)
- French broom (*Genista monspessulana*)
- Scotch broom (*Cytisus scoparius*)
- Eucalyptus (*Eucalyptus* spp.)
- Bermuda buttercup (*Oxalis pes-caprae*)
- Radish (*Raphanus* spp.)
- Castor bean (*Ricinus communis*)
- Germin ivy (*Senecio mikanioides*)
- Pink periwinkle (*Vinca major*)
- Gorse (*Ulex europaea*)
- Cardoon (*Cynara cardunculus*)
- Tamarisk (*Tamarix ramosissima*)
- Myoporum (*Myoporum* spp.)
- Tocalote (*Centaurea melitensis*)
- Yellow star-thistle (*Centaurea solstitialis*)
- Poison hemlock (*Conium maculatum*)
- Sweet fennel (*Foeniculum vulgare*)
- Giant reed (*Arundo donax*)
- Tree tobacco (*Nicotiana glauca*)
- Pepper tree (*Schinus* spp.)
- Ice plant (*Mesembryanthemum* spp.)
- Australian saltbush (*Atriplex semibaccata*)
- Spanish sunflower (*Pulicaria paludosa*)
- White sweet clover (*Melilotus alba*)
- Artichoke thistle (*Cynara cardunculus*)
- Oleandor (*Nerium oleandor*)
- Cocklebur (*Xanthium spinosum* and *X. strumarium*)
- Palms (*Washingtonia* and *Phoenix* spp.)
- Yucca spp.
- Jimson weed (*Datura* spp.)
- Johnsongrass (*Sorghum* spp.)
- Russian thistle (*Salsola tragus*)
- Milk thistle (*Silybum* spp.)

- Bull thistle (*Cirsium vulgare*)
- Scotch thistle (*Onopordum* spp.)
- Mallow (*Malva parviflora*)
- Nettle (*Urtica* spp.)
- Curly dock (*Rumex* spp.)
- Dodder (*Cuscuta indecora*)
- Burclover (*Medicago polymorpha*)
- Nutsedge (*Cyperus esculentus* L.)
- Alkali sida (*Malva* spp.)
- Gourd (*Cucurbita* spp.)
- Morningglory (*Ipomoea* spp.)
- Waterhyacinth (*Eichornia* spp.)
- Waterprimrose (*Ludwigia* spp.)
- Prickly lettuce (*Lactuca serriola*)
- Foxtail chess (*Bromus madritensis* ssp. *rubens*)
- Crabgrass (*Digitaria sanguinalis*)
- Large-seed Dodder (*Cuscuta indecora*)
- Waterhyssop (*Bacopa eisenii*)
- Smartweed (*Polygonum lapathifolium*)
- Rabbitfoot (*Polypogon monspeliensis*)
- Pepperweed (*Lepidium latifolium*)
- Morningglory (*Ipomoea* spp.)
- Lesser watercress (*Coronopus didymus*)
- Barnyard grass (*Echinochloa crus-galli*)
- Scarlet pimpernel (*Anagallis arvensis*)
- Bristly ox-tongue (*Picris echioides*)
- Mexican tea (*Chenopodium ambrosioides*)
- Lamb's quarters (*Chenopodium album*)
- Whitetop (*Cardaria* spp.)
- Water speedwell (*Veronica anagallis-aquatica*)
- Mexican primrose (*Oenothera speciosa*)
- Sweet pea (*Lathyrus odorata*)
- Kikuyu grass (*Pennisetum clandestinum*)
- Brassbuttons (*Cotula coronopifolia*)
- Filaree (*Erodium* spp.)
- Sow-thistle (*Sonchus asper*)
- Pokeweed (*Phytolacca americana*)
- Celery (*Apium graveolens*)
- Conyza (*Conyza bonariensis*)

6.3.4 HERBICIDE TREATMENT

1. In order to apply an unrestricted herbicide (Roundup, Rodeo, etc.), the contractor must have a Pest Control Business License, which requires that at least one individual employed by the contractor be in possession of a Qualified Applicators License (QAL). If a qualified

applicator is not present during treatment, **all** applicators must have undergone documented herbicide application training. All licenses must be issued by the State of California, registered in Orange County, and be of current status.

2. Spraying and or wick application of herbicide may be employed to control undesirable species. Only EPA approved glyphosate-based, systemic herbicides(e.g., Roundup or Rodeo) may be used, and **Rodeo must be used when applying herbicide within 100 feet of a natural watercourse or body of water.**
3. For foliar spray application, Roundup and Rodeo shall be applied at a minimum of a 1.5 percent solution, and during foliar wick application the herbicide shall be applied at a 33 percent solution; a 100 percent solution shall be used for all stump treatments. No pre-emergent herbicides may be used. A brightly colored dye shall be used in all applications. The material shall be a non-toxic, water-soluble liquid material such as “Blazon” by Milliken Chemical, or equivalent. The dye shall be mixed with the herbicide at no more than half the rate specified on the label (one quarter the rate will usually suffice).
4. Spraying may be conducted only when weather conditions are conducive to effective uptake of the herbicide by the targeted species (e.g., sunny, dry, and when plants are actively growing), and when wind conditions are such that herbicide drift is non-existent (5 mph or less). During herbicide application, protection for non-target species (e.g., native vegetation) is required.

6.3.5 EROSION CONTROL

1. In order to prevent unnecessary competition with the native plant community to be established, no grasses shall be seeded or planted as erosion control measures prior to the installation of the Natural Treatment Facility. In case of heavy rainfall conditions, non-vegetative erosion control measures (i.e., silt fence, sandbags, straw wattles, etc.) are to be used.
2. The Contractor shall be responsible for all erosion control required during the entire term of the contract. The Contractor is responsible for installing preventative erosion control measures as necessary to prevent erosion damage. This will include slowing the velocity and dispersing concentrated water that is entering and exiting the restoration site. Erosion

control measures shall be included in various items of work, and no additional compensation shall be allowed.

6.3.6 MATERIALS

1. The Contractor shall supply all materials necessary to complete the work in accordance with the specifications. All materials are subject to approval by the IRWD Biologist/Restoration Specialist.

Seed

The Contractor shall provide all seed material. The species to be included were selected based on native plants found in a local fresh water marsh plant community. All seed shall be purchased from S&S Seeds [(805) 684-0436], and must be collected from within a ten-mile radius of the project site and from a similar coastal microclimate regime, if available. All seed substitution decisions or alternative genetic sources shall be approved by the IRWD Biologist/Restoration Specialist. Upon receipt of the seed, the Contractor shall be responsible for ensuring the viability of the seed unit it is sown. All seed must be sown within 96 hours of being delivered to the Contractor.

Container Plants

The genetic source of all container plants will be within ten miles of the project site, if possible, and of similar microclimate regime (coastal Orange County). All plant substitution decisions or alternative genetic sources shall be approved by the IRWD Biologist/Restoration Specialist. Because the Contractor must guarantee 100 percent survival for the 120-day establishment period, all container plants must be observed and approved by the IRWD Biologist / Restoration Specialist and the Contractor at the time of delivery.

All plants shall be healthy and in good condition. The roots shall be young roots that fill the container and must not be wrapped around the sides of the container. Any plants that, in the opinion of the Contractor or the IRWD Biologist/Restoration Specialist, are incapable of surviving for 120-days following good installation techniques will be returned to the nursery to be replaced. Upon receipt of the container plants, the Contractor will be responsible for ensuring the health and good condition of the plants until they are installed. All container plants must be kept in an area that is safe from vandalism, herbivore browsing, and drying from winds.

Cuttings

All cuttings shall be collected from within ten miles of the project site. The following guidelines apply to collecting cuttings for immediate use on the site:

- a. Collect the cuttings within 24 hours of anticipated planting. Cuttings not planted within 24 hours of collection shall be disposed of in an appropriate manner.
- b. Take cuttings only from healthy, vigorous plants that are in a dormant state.
- c. Do not collect from more than 50 percent of the plants in a given area, and do not remove more than 50 percent of any plant.
- d. Cuttings shall be approximately 36 inches in length and shall range between 0.5 and 1.0 inches in diameter.
- e. Cut the top of each cutting square above a leaf bud; cut the base below a leaf bud at an angle of approximately 45 degrees. Use only sharp, clean tools.
- f. Trim all leaves and branches from the cuttings flush with the stem.
- g. Place cuttings submerged in water until planting time (within 24 hours of collection). Cuttings that are allowed to dry out shall not be used.

Mulch

The Contractor shall supply enough clean organic mulch to cover the watering basin of each plant installed. All mulch must be certified by the distributor that it is free of pesticide residue, eucalyptus, and palm. Mulch shall be a shredded "medium grind" mix. A minimum of 95 percent by weight of the materials shall pass a 3-inch screen with less than 20 percent of particles by weight passing a 1/8-inch screen. Organic content shall be minimum 90 percent based on dry weight and determined by ash method. Moisture content shall be 25 percent - 50 percent at time of delivery. All material must be woody in nature derived from yard trimming, wood residuals (no eucalyptus) or a combinations thereof. The mulch shall have an acceptable odor, like soil, musty, moldy or negligible. Unacceptable odor shall be sour, putrid or ammonia. Mulch material shall have been fully composted to a temperature of at least 130° F throughout the pile for a minimum 7-day period. If requested the supplier must provide the documentation for recorded temperatures and pile turning. The mulch shall be free of visible contaminants such as glass, metal, plastics and paper. Contractor shall submit mulch samples to IRWD for review and approval prior to delivery.

Other Materials

All other materials not specifically described herein, but required to complete this project, shall be furnished by the Contractor and are subject to the approval of the IRWD Biologist/Restoration Specialist.

6.4 PLANTING METHODS

6.4.1 CONTAINER PLANTS/WILLOW AND MULEFAT CUTTINGS

1. Following delivery by the nursery, the Landscape Contractor shall regularly water all nursery stock in containers and place them in a cool area that is protected from the sun and drying winds. The Landscape Contractor shall not allow plants to dry out before or while being planted. Wilted plants, whether planted or not, will not be accepted and shall be replaced at the Landscape Contractor's expense.
2. Container plantings shall be spaced in natural-looking patterns to replicate the character of natural stands. The plantings shall be set out on the site under the supervision of the District (IRWD) Restoration Ecologist and monitored with consideration given to the microclimate for each plant.
3. Shrubs/trees shall be planted according to the following directions:
 - All planting holes shall be excavated, have vertical sides with roughened surfaces, and be one and one-half (1.5) times the diameter and twice the depth of the plant's container for plugs, one gallon, five gallon, and fifteen gallon plant containers. For 24- and 48-inch boxes, the planting holes shall be excavated to six inches deeper than the box size and twice the width.
 - Any roots wrapped around the sides of the container shall be pulled loose from the rootball. The sides of the rootball shall be scarified to promote new root development. Plants shall be planted with the roots untangled and laid out in the planting hole to promote good root growth and prevent the plant from becoming rootbound. Roots shall be adequately protected at all times from sun and/or drying winds.
 - After excavation and before planting, the planting hole shall be filled approximately half full with water, backfilled with thoroughly broken up native topsoil, then completely filled with water to minimize soil settling after installation. Plants shall be set in the planting hole so that the crown of the root ball is 2 inches above finish grade. The crown of the plant shall not be depressed.
 - A watering basin shall be provided around each plant. Each plant is to be individually watered with sufficient water to reach to the lower roots at the time of planting. In the event that the season's rainfall is low, additional watering may be required if the plants have insufficient moisture to sustain them between rainfall events.

- Typical plant spacing:

Small shrubs	5' o.c.
Medium / Large shrubs	10' o.c.
Trees	20-30' o.c.

6.4.1.1 Willow and Mulefat Cuttings

1. Mulefat and willow cuttings shall be planted according to the following specifications and details:
 - Use one-inch rebar to create planting holes that are approximately 24 inches deep.
 - Fill each planting hole with water, and allow the water to absorb into the surrounding ground. Once the water has completely drained, be certain not to disturb the settled soil in the bottom of the planting hole. Repeat this watering process once more.
 - Apply a root stimulant to each cutting prior to planting, in accordance with manufacturer's instructions.
 - When most of the second filling of water has soaked into the ground, insert a cutting in the hole. The base of the cuttings shall be a minimum of 18 inches deep, and shall have three to five bud scars exposed above the finished grade.
 - Backfill with excavated material. The material shall be distributed evenly throughout, without clods or air pockets, and filled in without damaging the bark of the cutting.
 - Tamp down the backfill sufficiently to prevent easy removal of the cuttings.
 - Immediately following installation, deep soak each plant twice with sufficient water to reach the lowest part of the cutting. This will ensure that the cutting settles completely within the planting hole.

6.4.2 HAND SEEDING

1. Before broadcasting, the pure live seed (PLS) shall be mixed with a dispersal agent (rice hulls, bran, etc.) at a 2:1 ratio (dispersal agent to seed), which will aid in good seed dispersal and coverage. After broadcasting, the seed is to be lightly raked into the soil (but not covered) with a bamboo landscape rake or equivalent.

6.4.3 HYDROSEEDING

1. At the time of hydroseeding, all hydroseed mixing shall be performed in a clean tank (thoroughly rinsed a minimum of three times in the presence of the IRWD Biologist/Restoration Specialist) with a built-in, continuous agitation and re-circulation system of sufficient operating capacity to produce a homogeneous slurry, and a discharge system that will apply the slurry to designed areas at a continuous and uniform rate. The Contractor shall be responsible for providing all water required to hydroseed, as well as for providing a location to legally clean out the hydroseed tank.
2. The slurry preparation shall take place at the project site, and shall begin by adding water to the tank when the engine is at half throttle. Good recirculation shall be established when the water level has reached the height of the agitator; at this time seed shall be added; the long strand wood fiber mulch shall be added when the tank is at least 30 percent filled with water. The mulch used shall be 100 percent long strand wood fiber mulch (e.g., Conwed Hydro Mulch or Canfor EcoFiber); no paper mulch shall be used. The Contractor shall commence spraying once the tank is full.
3. The Contractor shall spray designed areas with the slurry in a sweeping motion and in an arched stream, until a uniform coat is achieved with no slumping or shadowing and the material is spread at the required rate per acre. The hydroseed slurry should float down from above as opposed to a direct stream. During hydroseed application, all container plants must be protected from damage (including but not limited to mulch coating, direct spray, dragging hose). The tanks must be emptied completely during each stage of hydroseeding. Excessive mulch coating on container plants must be removed. Intentional or unintentional damage caused by Contractor hydroseeding activity will be required to replace each lost plant.
4. The standard hydroseeding technique shall be employed as follows:
 - 1,500 lbs/acre of 100 percent wood fiber mulch (paper mulch shall not be used)
 - Specified pure live seed
 - 150 lbs of Ecology Control binder (or approved equal)
5. See the establishment period guidelines for various planting methods in the Monitoring and Maintenance section.

6.5 WETLAND VEGETATION

1. The main purpose of the natural treatment system is the treatment of various pollutants. Thus, plant selection is based primarily on need to achieve pollutant treatment and secondarily to provide wildlife habitat. Recommended materials should be native species selected for their ability to withstand periodic flooding and drier/drought conditions. In general, a diverse plant palette that can be maintained over long periods in winter and summer is the best method of pollution removal.
2. The shallow water channel sections (approximately one to two feet in depth) of Type I, Type II, and Type III wetlands will be planted with species from the cattail and bulrush series.
 - Species in the cattail series should include narrowleaf cattail (*Typha angustifolia*) and broadleaf cattail (*T. latifolia*).
 - Dominant species in the bulrush series should include California bulrush (*Scirpus californicus*) and coastal bulrush (*S. robustus*).
3. Planting in the wetland area will involve a uniform density of a single species of emergent plants across the entire channel in an effort to promote uniform flow through the channel cross section. For example, bands of cattail and bulrush series may be planted on alternate shallow water sections, with cattails planted along upstream sections, and bulrushes planted along the downstream sections. If plant density and type are not uniform across the width of the channel, then preferential flow paths and short-circuiting could develop, which reduces the uniformity of flows and overall treatment effectiveness.
4. Optimal planting densities vary between particular species. If vegetation is too dense, it may inhibit water circulation, and if too sparse, the vegetation is not productive and may not be able to provide enough of a food base for some species of wetland organisms. When hand planting plugs in wetland areas, species in the cattail series should be planted at a rate of 2,400 plugs/acre. Species in the bulrush series should be planted at a rate of 2,800 plugs/acre. When seeding wetland areas, species in the cattail series should be seeded at a rate of 0.5 pounds/acre. Species in the bulrush series should be seeded at a rate of 7.0 pounds/acre.

6.6 RIPARIAN VEGETATION (LWL TO HWL)

1. Vegetation in the riparian area adjacent to the wetlands serves important habitat functions and provides a transition between the wetlands and the surrounding habitat from the low water level (LWL) to the high water level (HWL). This riparian vegetation may also provide suitable habitat for wildlife

2. Understory vegetation (groundcover and shrubs) should transition from the cattail/bulrush habitat, through shallower water wetlands (less than one foot in depth), and into the wooded overstory habitat that will be less frequently inundated.
 - Overstory riparian species may include those in the mixed willow series such as black willow (*Salix gooddengii*), red willow (*S. laevigata*), arroyo willow (*S. lasiolepis*), Fremont cottonwood (*Populus fremontii*), California sycamore (*Platanus racemosa*), and coast live oak (*Quercus agrifolia*).
 - Shrub vegetation may include mulefat (*Baccharis salicifolia*), mexican elderberry (*Sambucus mexicana*), california rose (*Rosa californica*), california deergrass (*Muhlenbergia rigens*), and giant wild rye (*Leymus condensatus*).
 - Groundcover vegetation may be composed of a seed mix containing the following species and applied according to techniques described in Section 6.8.3:

Yerba mansa (<i>Anemopsis californica</i>)	3.0 lbs/acre
Mugwort (<i>Artemisia douglasiana</i>)	3.0 lbs/acre
California brome (<i>Bromus carinatus</i>)	4.0 lbs/acre
Meadow barley (<i>Hordeum brachyantherum</i>)	2.0 lbs/acre
Giant wildrye (<i>Leymus condensatus</i>)	2.0 lbs/acre
Foothill needlegrass (<i>Nassella lepida</i>)	1.2 lbs/acre
Purple needlegrass (<i>Nassella pulchra</i>)	4.5 lbs/acre
Marsh evening primrose (<i>Oenothera elata</i>)	0.5 lbs/acre
Branching phacelia (<i>Phacelia ramosissima</i>)	0.5 lbs/acre
Marsh fleabane (<i>Pluchea odorata</i>)	0.5 lbs/acre
Willow smartweed (<i>Polygonum lapathifolium</i>)	1.0 lbs/acre
Willow dock (<i>Rumex salicifolius</i>)	1.0 lbs/acre
California figwort (<i>Scrophularia californica</i>)	0.5 lbs/acre
Western verbena (<i>Verbena lasiostachys</i>)	1.0 lbs/acre

6.7 UPLAND/TRANSITION ZONE (HWL TO EDGE OF ACCESS ROAD)

1. Upland/Transition vegetation will serve as a buffer between the natural treatment system wetlands and the surrounding urban areas. Plant selection for these areas are intended to provide habitat for avian species as well as providing a transition element in a developed landscape. If required , an irrigation system designed to eliminate runoff into the NTS will regulate hydrology in upland areas.

- Overstory species may include western sycamore, coast live oak, western cottonwood
- Shrub vegetation may include California sagebrush, California buckwheat, Toyon, giant wild-rye, monkeyflower, California rose.
- Groundcover vegetation may be composed of a seed mix containing the following species and applied according to techniques described in Section 6.8.3:

California brome (<i>Bromus carinatus</i>)	4.0 lbs/acre
Golden yarrow (<i>Eriophyllum confertiflorum</i>)	1.0 lbs/acre
Coastal goldenbush (<i>Isocoma menziesii</i>)	2.0 lbs/acre
California goldfields (<i>Lasthenia californica</i>)	2.0 lbs/acre
Miniature lupine (<i>Lupinus bicolor</i>)	4.0 lbs/acre
Arroyo lupine (<i>Lupinus succulentus</i>)	7.0 lbs/acre
California deergrass (<i>Muhlenbergia rigens</i>)	0.5 lbs/acre
Foothill needlegrass (<i>Nassella lepida</i>)	4.0 lbs/acre
Purple needlegrass (<i>Nassella pulchra</i>)	4.5 lbs/acre
Branching phacelia (<i>Phacelia ramosissima</i>)	1.0 lbs/acre
California figwort (<i>Scrophularia californica</i>)	0.2 lbs/acre
Blue-eyed grass (<i>Sisyrinchium bellum</i>)	3.0 lbs/acre

6.8 PLANTING DENSITIES

1. Planting densities of vegetation in the riparian and upland areas may be achieved by utilizing the following guidelines. For understory vegetation, apply seed mixes using hydroseeding techniques discussed in **Section 6.4.3**. Understory shrub plantings should be planted at a density of 5-10 feet on center and overstory trees planted at approximately 20-30 feet on center using containerized planting methods described in **Section 6.4.1**.

6.9 SOILS AND SUBSTRATE

1. Soils are an important part of constructed wetlands and their associated riparian areas. Wetland soils provide a substrate for plant growth and production, habitat for

microorganisms, and act as a semi-permeable barrier that helps to slow the loss of water due to infiltration.

2. The soil within a wetland must provide substrate to support growth of emergent plants and provide suitable habitat for microorganisms. In wetlands, a fine organic layer provides an environment for plant growth by maintaining moisture and allowing for the decomposition of organic matter. The surface layer acts as a filter for finer particles still in suspension and maintains an environment for the microbial community to help breakdown urban runoff pollutants. Soil pH levels between 5.0 and 7.0 provide the ideal habitat for microbial production. The substrate should be thick enough (approximately 24 inches) to allow for the establishment of plants.
3. Another important function of soils in wetland areas is its ability to act as a barrier to water infiltration. The quantity of water infiltrating into the subsurface depends on the properties of the soil underlying the bottom of the wetlands, and on groundwater elevations. Soils with small grain size, such as clays and silts, provide a better barrier to water infiltration than soils with larger grain size such as sand, large areas of cobble or gravel. Areas of bedrock shall be made suitable for plant growth and infiltration through fractures shall be prevented.
4. According to the Soil Conservation Service, major portions of the District contain soils characterized by low infiltration capacities (silty-loam soils inter-bedded with fine textured soils and clayey soils with a high swelling potential). However, there are areas where soils with higher infiltration capacities (fine to coarse textured sandy loam) predominate. Soil conditions and infiltration at individual sites will be evaluated during detailed design studies. The import of more suitable substrate may be required at sites that contain soils with high infiltration rates. Liners at the bottom of the wetland facilities will be considered for all sites where unsuitable soils are present, or where other environmental conditions dictate. The liners can be either synthetic geotextile materials or 18-24 inches of silt loam, clay loam, or dried organic muck.

7.0 IRRIGATION

7.1 GENERAL

1. Natural treatment systems require a minimum inlet flow rate in order to establish and maintain the vegetation. Generally, the minimum flow will be provided by urban runoff. In areas not subject to urban runoff irrigation, supplemental irrigation with recycled water may be required. Procedural Guidelines for the use of recycled water for irrigation are contained in the IRWD Procedural Guidelines, Section 5 and apply to recycled water facilities for natural treatment system irrigation, in addition, IRWD requires separate irrigation systems for trees and shrubs.

7.2 SYSTEM CRITERIA

1. The natural treatment systems consist of several landscape systems/hydro zones (see Figure 2) that will require varied irrigation systems to establish and provide for long-term survival of the various plant communities. The irrigation system must minimize runoff into areas below the high water line.
 - A. Upland Area: Defined as the community/public edge planted with ornamental, drought-tolerant landscape to blend with the various regions and neighborhood communities outside of where the natural treatment system is located. Upland area drainage shall be directed to the development's storm drain system. Drainage from upland slopes adjacent to the NTS area shall be directed to the development's storm drain system and not allowed to enter the NTS from the side or in a short circuiting manner.
 1. Irrigation Equipment: Conventional overhead rotor, spray, or bubbler irrigation equipment. Irrigation spray shall be directed uphill and away from the NTS
 - B. Upland/Transition Zone: Defined as the slope area between the Upland Area and the riparian area of the natural treatment system or HWL. This area may be planted with natural vegetation to limit irrigation runoff into the natural treatment system facility.
 1. Irrigation Equipment: Bubbler and drip irrigation systems may be used to provide for establishment of container plants or use hydroseed mix, without irrigation system, propagated by natural rainfall. The container plants and trees shall have watering basins and other measures shall be taken to eliminate irrigation runoff into NTS. Shrubs shall be on separate irrigation systems from tree.

- C. Riparian Area: Defined as the area between the HWL and the LWL.
 - 1. Irrigation Equipment: None Preferred. Use a hydroseed mix propagated by natural rainfall to prevent irrigation runoff into NTS, in accordance with Section 6.6 of this document.
- D. Wetland Area: Defined as the area below the LWL within the basin.
 - 1. No irrigation system in the wetland area will be permitted.

7.3 EQUIPMENT LIST

- 1. The District has established this standard list of irrigation equipment for all treatment facilities to be maintained by the District.
 - **Controller: CalSense ET2000e-Station__-GR** mounted within a metered vandal resistant CalSense enclosure assembly. These irrigation controllers are available in 8, 12, 16, 18, 24, 32, or 40 station models (Contractor required to have CalSense sign off on the installation)..
 - Flow Sensor: CalSense FM series.
 - Recycled Basket Strainer: Hayward #72 SS. 30 mesh or finer.
 - Potable Backflow Device: Febco Model 825 YS.
 - Master Valve: Rainbird PEB.
 - Pressure Regulator: Wilkins #510.
 - Irrigation Remote Control Valve: Rainbird PEB.
 - Rotor Heads for Basin: Hunter PGS, PGP, PGH.
 - Rotor Heads for Side Slopes: Hunter PGS, PGP, PGH.
 - Spray Heads: Rainbird 1800 series SAM PRS
 - Bubbler Heads: Rainbird 1400 series.

7.4 CALIFORNIA REGIONAL WATER QUALITY CONTROL BOARD, SANTA ANA NOTIFICATION

- 1. Use of recycled water requires coordination with the California Regional Water Quality Control Board, Santa Ana River Basin (CRWQCB). The CRWQCB must be notified in advance that the use of recycled water may be necessary within the subsequent 7-day period. Notification will also be required on the day prior to application of recycled water.

8.0 MONITORING AND MAINTENANCE OF LANDSCAPING

8.1 LANDSCAPE MONITORING AND ACCEPTANCE CRITERIA

1. During the establishment period, the developer shall be responsible for monitoring the landscape and provide routine maintenance.
2. Performance Standards Required:
 - Landscape with irrigation system
 - Establishment Period, 120 days, with 100 percent plant survival, with a extended maintenance period to coincide with the hydroseed establishment period with a 80 percent survival rate.
 - Landscape with no irrigation system (Hydroseed)
 - Establishment Period, minimum one year or greater to achieve 75 percent native coverage and less than 5 percent nonnative coverage

8.2 PERFORMANCE MONITORING

1. The District shall conduct inspection and water quality monitoring for each site based on a schedule established by the District and also during and after major storm events. Routine inspections will be performed to monitor sediment accumulation, plant condition, vector monitoring and mosquito fish monitoring.
2. Water quality monitoring will consist of continuous flow and water level measurement, sampling to determine influent and effluent concentration of pollutant concentrations and field measurement of general water quality parameters. IRWD, at its discretion, may undertake to perform any or all of the above monitoring during the establishment period. Based on the monitoring results, IRWD will determine if modifications to the system design are required or if final acceptance of the facility may be granted.

8.3 LANDSCAPE MAINTENANCE

1. The developer is required to provide maintenance of the landscape vegetation during the establishment period, including replacement of vegetation, removal of invasive vegetation, herbivore control, irrigation system, trash removal and general care of herbaceous vegetation, shrubs and trees.

8.3.1 MAINTENANCE OF LANDSCAPE

1. Normal maintenance will include weeding, herbivore control, and irrigation. During the establishment period after the installation is complete, the plant community must be maintained regularly to ensure its successful establishment. At the end of the establishment period, a thorough observation of the restoration areas shall be conducted by the Contractor and Restoration Ecologist, and a list of those plants that are alive and healthy shall be submitted to the Contractor at that time. The Contractor shall replace all dead or missing container plants required to achieve the 100 percent survival rate required through the establishment period. The Contractor may choose to plant more than the total required to achieve this standard.

8.3.2 REPLACEMENT OF VEGETATION

1. All vegetation will be guaranteed during the establishment period by the Contractor (see performance standards). If any vegetation needs to be replaced during this period, the Contractor will be responsible for replacement. Partial acceptance of a portion of the NTS facility landscape is not acceptable.

8.3.3 REMOVAL OF INVASIVE VEGETATION

1. In order to help establish the developing plant community, the Contractor shall remove all nonnative weeds to reduce the amount of competition for natural resources, including water, nutrients, and sunlight. The amount of weeding required will be determined by the amount of weed seed in the soil, weather conditions, and the Contractor's diligence in removing the weeds, thereby reducing the weed seed bank. The Contractor shall be required to satisfy the following weeding criteria continuously throughout the maintenance period.
 - The percent cover by weeds must be kept below 5 percent at all times. If at any time the site contains more than 5 percent cover by weeds, the Contractor will forfeit 10 percent of the total maintenance period payment for each month of noncompliance and shall incur liquidated damages of 10 percent of maintenance period payment per day of noncompliance.
 - No more than 10 percent of the site may be covered by weeds that have reached the seed dispersal stage. If the site contains more than 10 percent cover of weeds that are in the seed dispersal stage, the Contractor will forfeit 75 percent of the maintenance period payment.

8.3.3.1 Methods of Removal

1. All non-native invasive weeds shall be removed mechanically, if feasible. In circumstances where mechanical control is not effective, it is appropriate to utilize systemic herbicides that have been approved by the U.S. Environmental Protection Agency (EPA) for use in aquatic situations. In no case shall weedy species exceed 12 inches in height. All nonnative vegetation debris accumulated as a result of weed-removal activities shall be legally disposed of off site. Target species and those determined by the IRWD Biologist/Restoration Specialist to be inconsistent with the success of the establishment effort shall be removed. Targeted weed species include, but are not limited to, the following:

- Mustard (*Hirschfeldia* spp. and *Brassica* spp.)
- Pampus grass (*Cortaderia selloana*)
- Bermuda grass (*Cynodon dactylon*)
- Hottentot-fig (*Carpobrotus edulis*)
- Garland chrysanthemum (*Chrysanthemum coronarium*)
- French broom (*Genista monspessulana*)
- Scotch broom (*Cytisus scoparius*)
- Eucalyptus (*Eucalyptus* spp.)
- Bermuda buttercup (*Oxalis pes-caprae*)
- Radish (*Raphanus* spp.)
- Castor bean (*Ricinus communis*)
- Germin ivy (*Senecio mikanioides*)
- Pink periwinkle (*Vinca major*)
- Gorse (*Ulex europaea*)
- Cardoon (*Cynara cardunculus*)
- Tamarisk (*Tamarix ramosissima*)
- Myoporum (*Myoporum* spp.)
- Tocalote (*Centaurea melitensis*)
- Yellow star-thistle (*Centaurea solstitialis*)
- Poison hemlock (*Conium maculatum*)
- Sweet fennel (*Foeniculum vulgare*)
- Giant reed (*Arundo donax*)
- Tree tobacco (*Nicotiana glauca*)
- Pepper tree (*Schinus* spp.)
- Ice plant (*Mesembryanthemum* spp.)
- Australian saltbush (*Atriplex semibaccata*)
- Spanish sunflower (*Pulicaria paludosa*)
- White sweet clover (*Melilotus alba*)
- Artichoke thistle (*Cynara cardunculus*)
- Oleandor (*Nerium oleandor*)
- Cocklebur (*Xanthium spinosum* and *X. strumarium*)
- Palms (*Washingtonia* and *Phoenix* spp.)

- Yucca spp.
- Jimson weed (*Datura* spp.)
- Johnsongrass (*Sorghum* spp.)
- Russian thistle (*Salsola tragus*)
- Milk thistle (*Silybum* spp.)
- Bull thistle (*Cirsium vulgare*)
- Scotch thistle (*Onopordum* spp.)
- Mallow (*Malva parviflora*)
- Curly dock (*Rumex* spp.)
- Dodder (*Cuscuta indecora*)
- Burclover (*Medicago polymorpha*)
- Nutsedge (*Cyperus esculentus* L.)
- Alkali sida (*Malva* spp.)
- Gourd (*Cucurbita* spp.)
- Morningglory (*Ipomoea* spp.)
- Waterhyacinth (*Eichornia* spp.)
- Waterprimrose (*Ludwigia* spp.)
- Prickly lettuce (*Lactuca serriola*)
- Foxtail chess (*Bromus madritensis* ssp. *rubens*)
- Crabgrass (*Digitaria sanguinalis*)
- Largeseed Dodder (*Cuscuta indecora*)
- Waterhyssop (*Bacopa eisenii*)
- Smartweed (*Polygonum lapathifolium*)
- Rabbitfoot (*Polypogon monspeliensis*)
- Pepperweed (*Lepidium latifolium*)
- Morningglory (*Ipomoea* spp.)
- Lesser watercress (*Coronopus didymus*)
- Barnyard grass (*Echinochloa crus-galli*)
- Scarlet pimpernel (*Anagallis arvensis*)
- Bristly ox-tongue (*Picris echioides*)
- Mexican tea (*Chenopodium ambrosioides*)
- Lamb's quarters (*Chenopodium album*)
- Whitetop (*Cardaria* spp.)
- Water speedwell (*Veronica anagallis-aquatica*)
- Mexican primrose (*Oenothera speciosa*)
- Sweet pea (*Lathyrus odorata*)
- Kikuyu grass (*Pennisetum clandestinum*)
- Brassbuttons (*Cotula coronopifolia*)
- Filaree (*Erodium* spp.)
- Sow-thistle (*Sonchus asper*)
- Pokeweed (*Phytolacca americana*)
- Celery (*Apium graveolens*)
- Conyza (*Conyza bonariensis*)

8.3.3.2 Herbicide Treatment Guidelines

1. In order to apply an unrestricted herbicide (Roundup, Rodeo, etc.), the contractor must have a Pest Control Business License, which requires that at least one individual employed by the contractor be in possession of a Qualified Applicators License (QAL). If a qualified applicator is not present during treatment, all applicators must have undergone documented herbicide application training. All licenses must be issued by the State of California, registered in Orange County, and be of current status.
2. Spraying and or wick application of herbicide may be employed to control undesirable species. Only EPA approved glyphosate-based, systemic herbicides(e.g., Roundup or Rodeo) may be used, and **Rodeo must be used when applying herbicide within 100 feet of a natural watercourse or body of water.**
3. For foliar spray application, Roundup and Rodeo shall be applied at a minimum of a 1-1/2 percent solution, and during foliar wick application the herbicide shall be applied at a 33 percent solution; a 100 percent solution shall be used for all stump treatments. No pre-emergent herbicides may be used. A brightly colored dye shall be used in all applications. The material shall be a non-toxic, water-soluble liquid material such as “Blazon” by Milliken Chemical, or equivalent. The dye shall be mixed with the herbicide at no more than half the rate specified on the label(one quarter the rate will usually suffice).
4. Spraying may be conducted only when weather conditions are conducive to effective uptake of the herbicide by the targeted species (e.g., sunny, dry, and when plants are actively growing), and when wind conditions are such that herbicide drift is non-existent (5 mph or less). During herbicide application, protection for non-target species (e.g., native vegetation) is required.

8.3.4 GENERAL SHRUB CARE

1. Typical maintenance considerations include watering thoroughly during the establishment period if necessary and inspecting shrubs closely to discover and control pests or diseases in their early stages. The only other maintenance requirement is occasional pruning.

8.3.5 GENERAL TREE CARE

1. Trees require virtually the same maintenance as shrubs (i.e., watering, pruning, and inspecting for diseases). One additional maintenance procedure is staking. During installation, the developer will stake all trees. The stakes shall be removed as soon as the trees are able to stand on their own. Stakes are usually only needed through the first season.

8.3.6 DISTURBANCE CONCERNS

1. The developer shall be aware of the following maintenance restrictions:
 - a. Breeding / Nesting Season
 - b. Migration
 - c. Surrounding jurisdictional wetlands
 - d. Endangered species
 - e. Local bird / mammal / reptile / amphibian
2. Vegetation spraying / removal will be limited between March 1 and September 15 if concerns a,b,c,d and e above apply. A qualified biologist, to ensure compliance with the Endangered Species Act, the California Endangered Act and Federal Migratory Bird Treaty Act, shall monitor any vegetation removal or earthwork between March 1 and September 15 in or in the vicinity of existing habitat. This monitor shall have the authority to stop or otherwise divert work to avoid impacts as necessary.
3. Waterfowl migration normally starts in late October and ends late January. Vegetation removal can proceed during this period, but waterfowl disturbance such as noise levels, time of day, and frequency need to be addressed.
4. After final acceptance of the natural treatment system facility, the IRWD will assume responsibility for monitoring and maintenance.

8.4 PEST CONTROL

1. Insect and herbivore damage control shall be the responsibility of the Contractor, using only those methods approved by the IRWD Biologist/Restoration Specialist. The Contractor shall implement control measures, which may require fencing or caging all container plants at the earliest sign of damage. In addition, the Contractor shall treat any insect infestation as

necessary to protect the health and establishment of the plant community per the recommendation of the IRWD Biologist/Restoration Specialist.

8.5 IRRIGATION

1. Irrigation shall be applied in a manner that encourages deep rooting of the installed plant community. In addition, excessive runoff by irrigation should be kept to a minimum. The use and method of irrigation are the responsibility of the Contractor, and no further compensation will be allowed. The source and cost of the water shall be the responsibility of the Contractor and shall be included in the maintenance price.

9.0 SECURITY AND SIGNAGE

1. Natural treatment system facilities may utilize shallow and ponded water areas for water quality treatment purposes. At the time of final design, consideration will be given to mitigating any significant hazard to public safety by the facility through the inclusion of fencing, signage, or special design features, based on the specific physical circumstances at the site. In addition, signage in English and Spanish will be considered at the site where it can be effectively used to describe the functions of the facility to the public. Recycled water facilities will be clearly identified according to the requirements of Section 5.

10.0 PERMITS

1. Prior to construction, the developer will be required to obtain all required environmental clearances for the proposed natural treatment system facility. The following table summarizes the majority, but not all, of the possible federal, state, and local permits from various agencies that may be required prior to construction. Contact information can be obtained from the respective agencies' website.

Agency	Permit
U.S. Army Corps of Engineers	Section 404 permit
State Water Resources Conservation Board	General (NPDES) construction activity storm water permit
Regional Water Quality Control Board	Section 401 Water Quality Certification
	General dewatering permit
United States Fish and Wildlife Service	Section 7 of the Endangered Species Act (ESA)
	Section 10 of the ESA, known as the "incidental take permit"
California Department of Fish and Game	Notification of Lake or Streambed Alteration form (FG2023) and Project Questionnaire form (FG 2024)
Various (California Environmental Quality Act) (CEQA)	Confirm that the conditions included in the Master EIR for the specific facility has not changed
California Department of Transportation	Encroachment permit
Local Landowners	Entry permit or landowner easement
Orange County Vector Control	Confirm that the conditions included in the Master Plan / EIR are adhered to.

11.0 PROPERTY ACCESS AND EASEMENTS

1. The natural treatment system sites are located on property owned by various private organizations and governmental agencies. The developer shall abide by the terms of any formal agreements with property owners that have been negotiated for construction, operation and maintenance access.

12.0 DELIVERABLES

1. Submit as built plans (mylars and electronic files - CAD and to scale PDF) along with two sets (11 x 17) of laminated color-coded irrigation system layout plan sheets. Engineer shall also prepare and submit an Operations and Maintenance Manual for each NTS as outlined in Appendix A.

13.0 INSPECTION

1. NTS Facility inspection shall be performed by IRWD Inspector. The contractor shall coordinated Non-NTS facility components with the appropriate city or agency.

APPENDIX A
NTS O&M MANUAL

APPENDIX A

NTS O&M MANUAL

Manual shall be prepared in a report format, and at a minimum, shall cover the items described in the following sections.

Section 1. Check List - Information Required

- Introduction
- Purpose of manual
- General description of facility
- Facility design criteria
- Inspection and work items to be accomplished at site before, during and after the storm event
- Detailed inspection: surface and subsurface drainage structures and facilities; inlet/outlet structures; roads; graded earth slopes; fencing and gates; vegetation; rodent damage; irrigation system
- Operational conversion activities: dry and wet weather control structures
- Silt removal process, limits, and responsibilities
- Vegetation control and removal
- Weed abatement
- Vector Control
- Trash debris removal
- Routine and non-routine maintenance and repair items
- Water quality monitoring and reporting
- Structural maintenance and repairs
- Control structure operation
- Landscape and irrigation system maintenance process and responsibilities
- Maintenance and repair process and responsibilities
- Identification of special requirements or restrictions from regulatory permits and responsibilities for performance
- Joint uses; special use conditions; gates and locks

- Hazardous materials / waste management
- Disposal of waste materials
- Emergency response
- Identification of Potential “extraordinary” flood control maintenance activities and responsibility for performance of such work
- Pump operation
- Notification process
- Exhibits and attachments to be included: overall map of NTS sites; location map for project; depictions of areas of responsibilities, project footprint, and access; storm drain map; drainage pattern map; hydrology study; project plans (grading / landscape); regulatory permits; easement and encroachment permits; contact numbers; bill of sale; equipment manuals; etc.

Section 2. Report Format:

Manual Report format shall be as follows:

- I. INTRODUCTION
- II. PURPOSE OF MANUAL
- III. GENERAL DESCRIPTION OF FACILITY
 - A. Definition “Normal” Flood Control Related Maintenance Activity and Responsibility at the Site.
 - B. Identification of Potential “Extraordinary” Flood Control Maintenance Activities and Responsibility at the Site.
- IV. FACILITY DESIGN CRITERIA
- V. FACILITY INSPECTIONS
 - A. Schedule of NTS Facility Inspections
 - 1. Pre-Storm Season Inspection
 - 2. Wet Weather Inspections
 - 3. Post-Storm Season Inspection
 - 4. Dry Weather Inspections
 - B. Description of Detailed Inspections
 - 1. Surface Drainage Facilities
 - 2. Subsurface Drainage Structures
 - 3. Inlet Works
 - 4. Outlet Works
 - 5. Access Roads

- 6. Graded Earth Slopes
- 7. Fencing and Gates
- 8. Vegetation
- 9. Rodent Damage
- 10. Irrigation System
- C. Operational Conversion Activities
 - 1. Dry Weather Control Structures
 - 2. Wet Weather Control Structures

VI. ROUTINE MONITORING AND MAINTENANCE ACTIVITIES AND FREQUENCIES

- A. Sediment Removal
- B. Vegetation Control and Removal.
- C. Weed abatement
- D. Rodent Control
- E. Vector/Mosquito Control
- F. Trash and Debris Removal
- G. Routine and Non-Routine Maintenance and Repair Items
- H. Water Quality Monitoring and Reporting
- I. Structural Maintenance and Repairs
- J. Control Structure Operation Landscape and Irrigation System Maintenance Process and Responsibilities Maintenance and Repair Process and Responsibilities
- K. Identification of Special Requirements or Restrictions from Regulatory Permits and Responsibility for Performance
- L. Joint Use Access/Maintenance Roads, Gates and Locks
- M. Hazardous Materials/Waste Management
- N. Disposal of Waste Materials
- O. Emergency Response
- P. Identification of Potential “Extraordinary” Flood Control Maintenance Activities and Responsibility for Performance of such work
- Q. Pump Operation
- R. Notification Process

VII. EXHIBITS

- 1. Project Location Map
- 2. Map Showing Access/Maintenance Roads and Points of Access to Facility; Areas of Responsibility; project footprint Facility
- 3. Right-of-Way Map

VIII. ATTACHMENTS

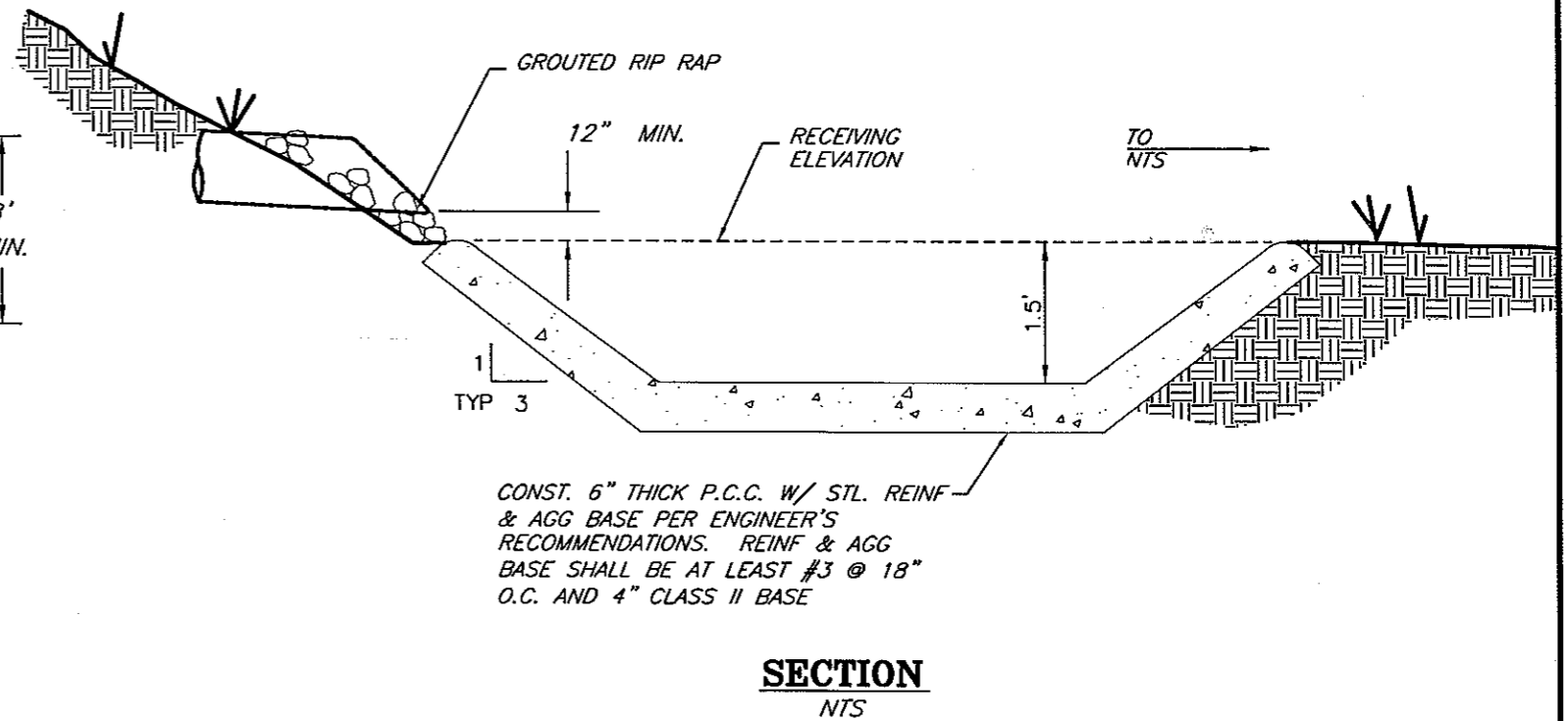
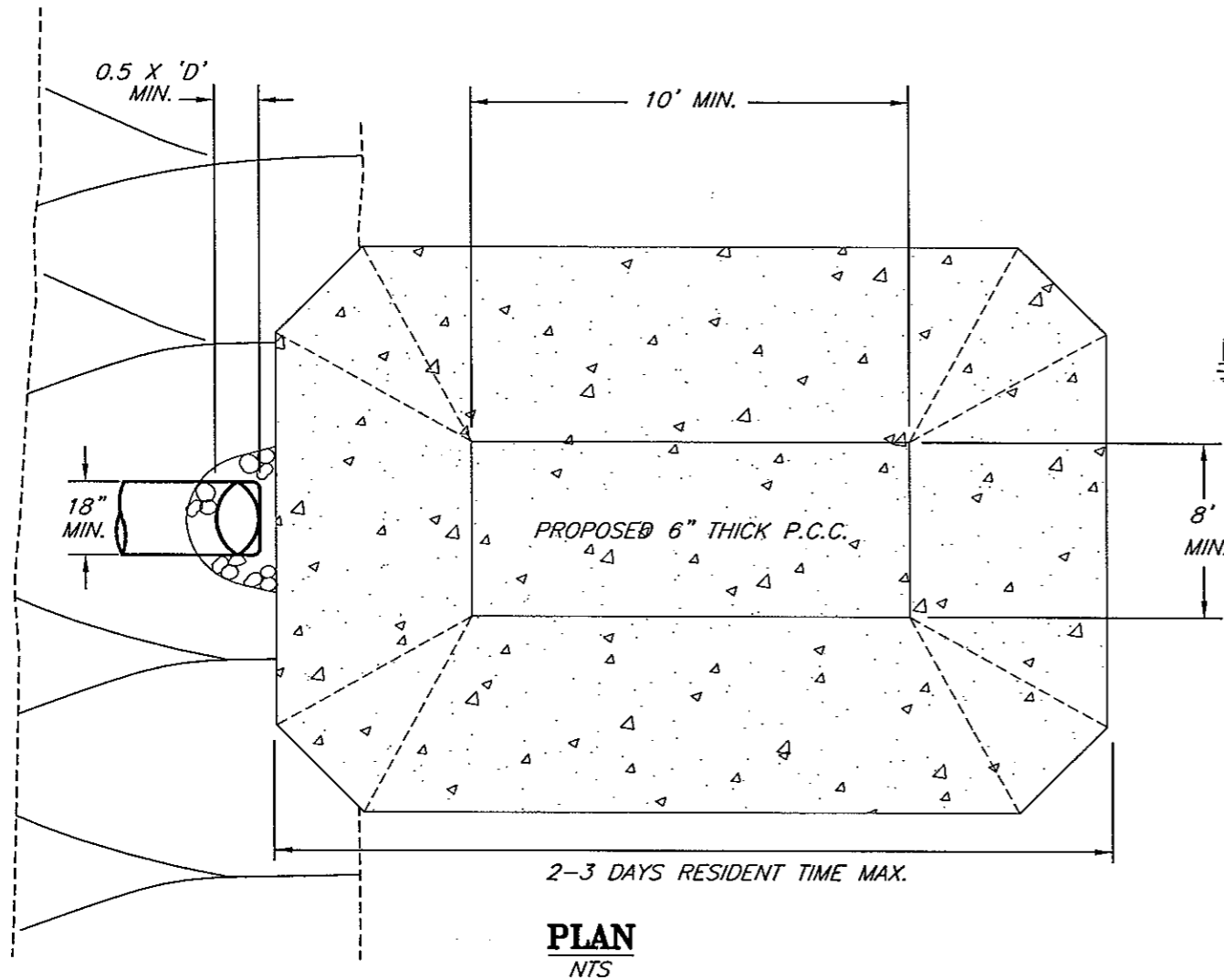

- A. California Department of Fish and Game Section 1603 Streambed Alteration Agreement
- B. Department of the Army, Los Angeles OCFCD, Corps of Engineers Section 404 Clean Water Act Permit
- C. Regional Water Quality Control Board Section 401 Clean Water Act Certification
- D. Department of Water Resources, Division of Safety of Dams Certificate of Approval and Conditions (Projects at Retarding Basins Within DSOD Jurisdiction)
- E. Property Encroachment Permit
- F. Easement
- G. Bill of Sale
- H. Equipment Manuals
- I. Hydrology Study (Tributary Area & SD Runoff Map w/ acreage)
- J. Contact Numbers (Agency, City, County, SCE, Association etc.)
- K. Drainage Pattern Maps (In/Out)
- L. Storm Drain Map (As-Built Connection points) with Reference Numbers
- M. "As-Built" Facility Plans (Grading / Landscape)
- N. Other Permits or Agreements required for Construction, Operation and Maintenance of NTS Facility, if required
- O. As-built irrigation system layout in a 11 x 17, laminated color coded format to be stored in the irrigation control cabinet.

NTS GUIDELINE DRAWINGS

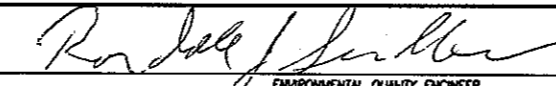

NOTES:

1. LENGTH OF SEDIMENT BASIN SHALL BE SUFFICIENT TO DISSIPATE ENERGY AND ALLOW FOR SETTLEMENT OF SEDIMENT.

NO.	BY	DATE	REVISIONS	APPROVED	DATE: 11-28-05		IRVINE RANCH WATER DISTRICT NTS GUIDELINE DRAWING	
					 11-28-05 ENVIRONMENTAL QUALITY ENGINEER		DRY WEATHER FLOW - SMALL SEDIMENT BASIN	NTS-1
					 1/28/05 ENVIRONMENTAL QUALITY MANAGER			
					NO SCALE			

INSTALL 42" HIGH - 2" DIA. GALVANIZED STEEL RAILING WITH CROSS MEMBER AT MID-HEIGHT. ATTACH ONE TYPE N SIGN WITH HIGH INTENSITY RED REFLECTIVE SHEETING (SEE CITY OF IRVINE STD PLAN 400 FOR SIGN) AT CENTER OF RAILING.

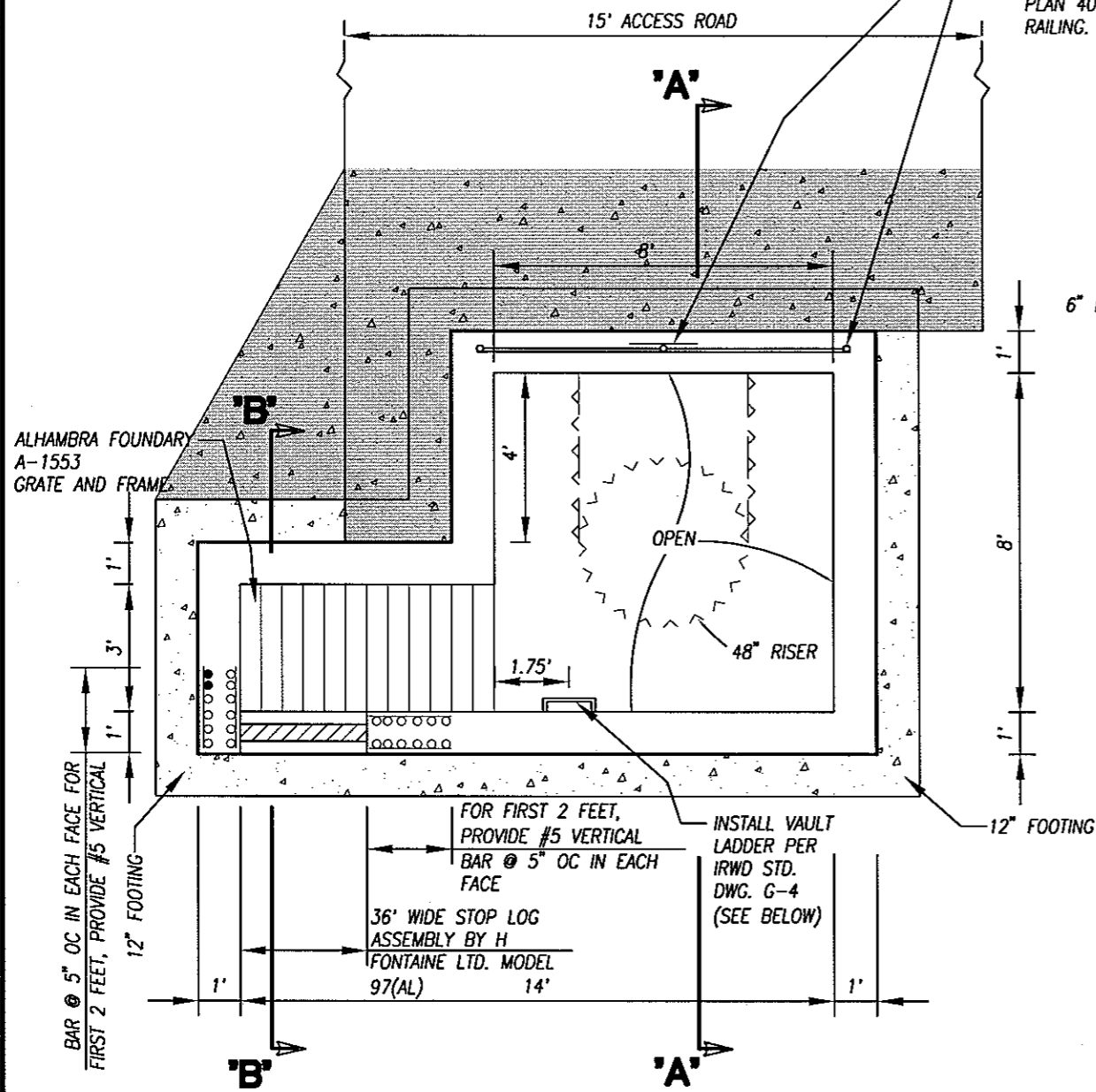

PLAN VIEW
SCALE: 1" = 4'-0"

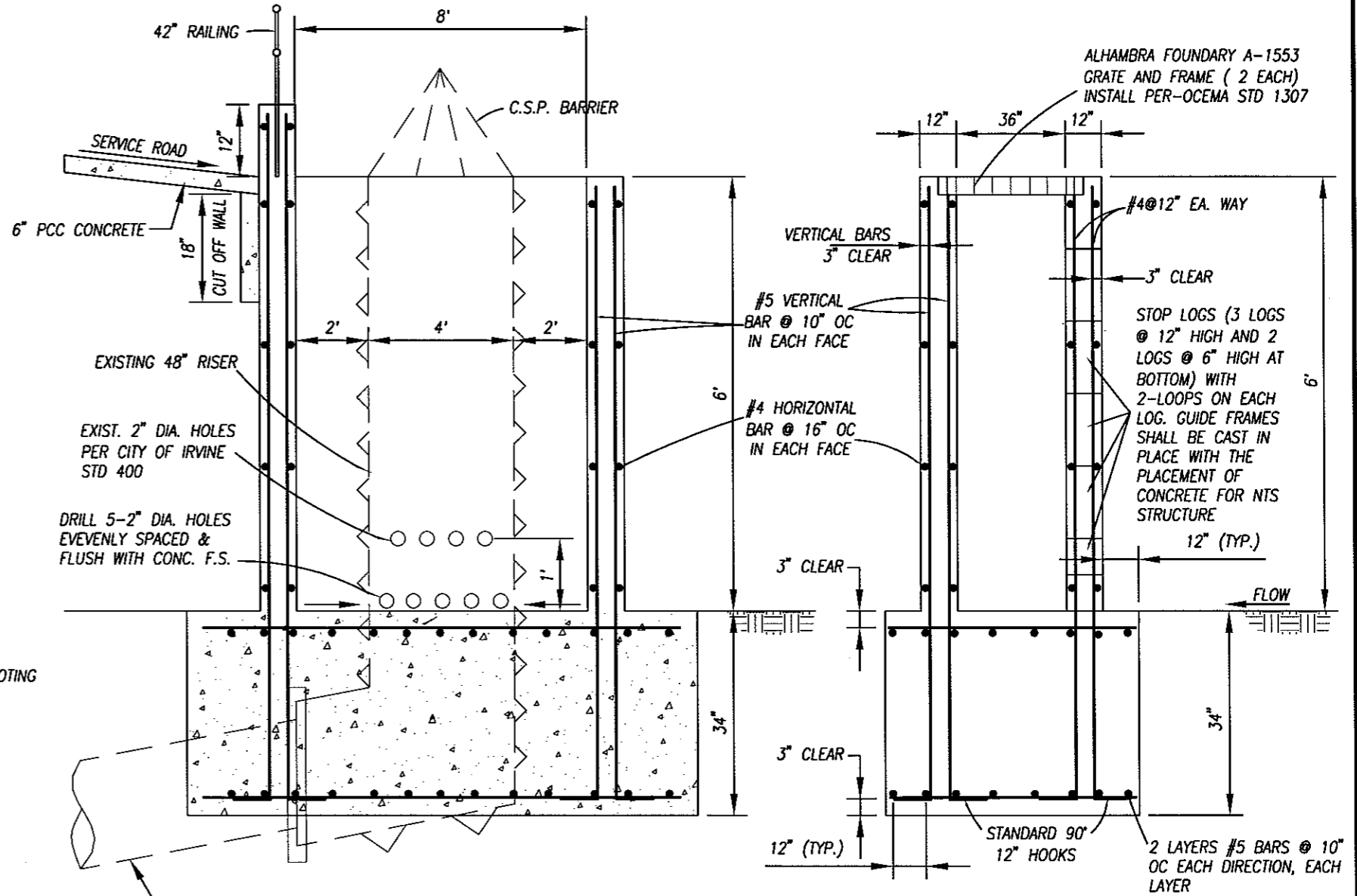

SECTION A-A
NTS

SECTION B-B
NTS

NOTE:
f'c = 4000 PSI @ 28 DAY
fy = 60000 #5
fy = 40000 #4

NO.	BY	DATE	REVISIONS	APPROVED	DATE: 03-11-05
					DRAWN:
					CHECKED:
					NO SCALE

Randell Sundry 3-31-05
ENVIRONMENTAL QUALITY ENGINEER DATE

[Signature] 3/31/05
QUALITY MANAGER DATE



IRVINE RANCH WATER DISTRICT NTS GUIDELINE DRAWING

LEVEL CONTROL OUTLET STRUCTURE DETAIL

NTS-2

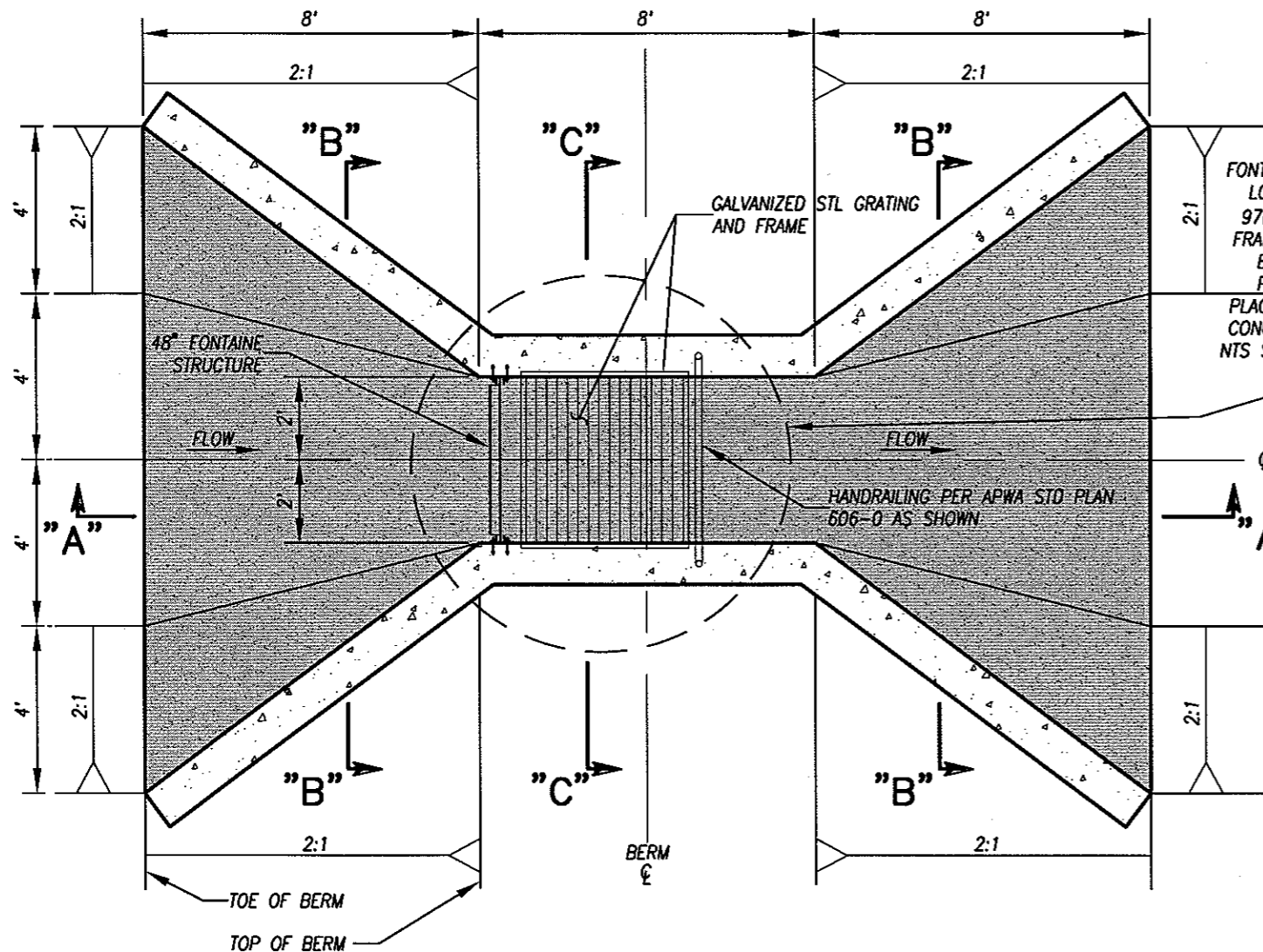

PLAN
SCALE: 1" = 4'-0"

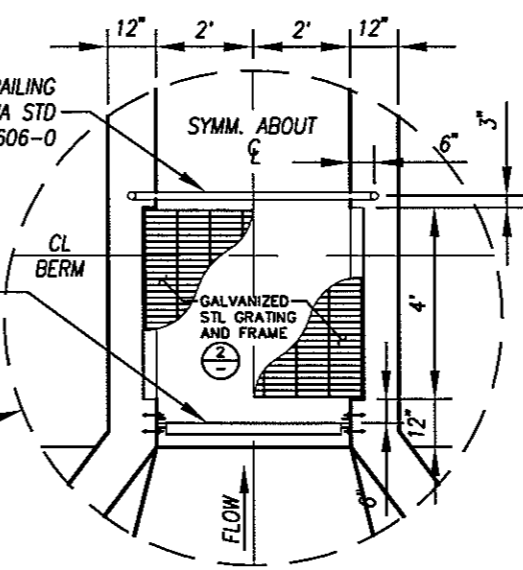

PLAN DETAIL
STOP LOG & GRATING
SCALE: 1" = 4'-0"

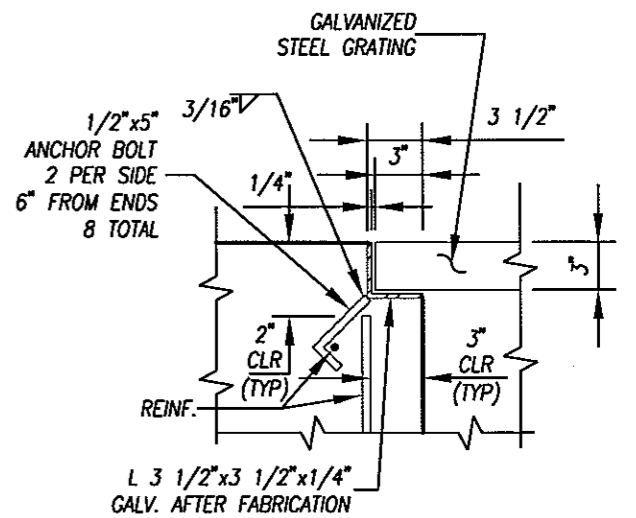

DETAIL GRATING FRAME 2
N.T.S.

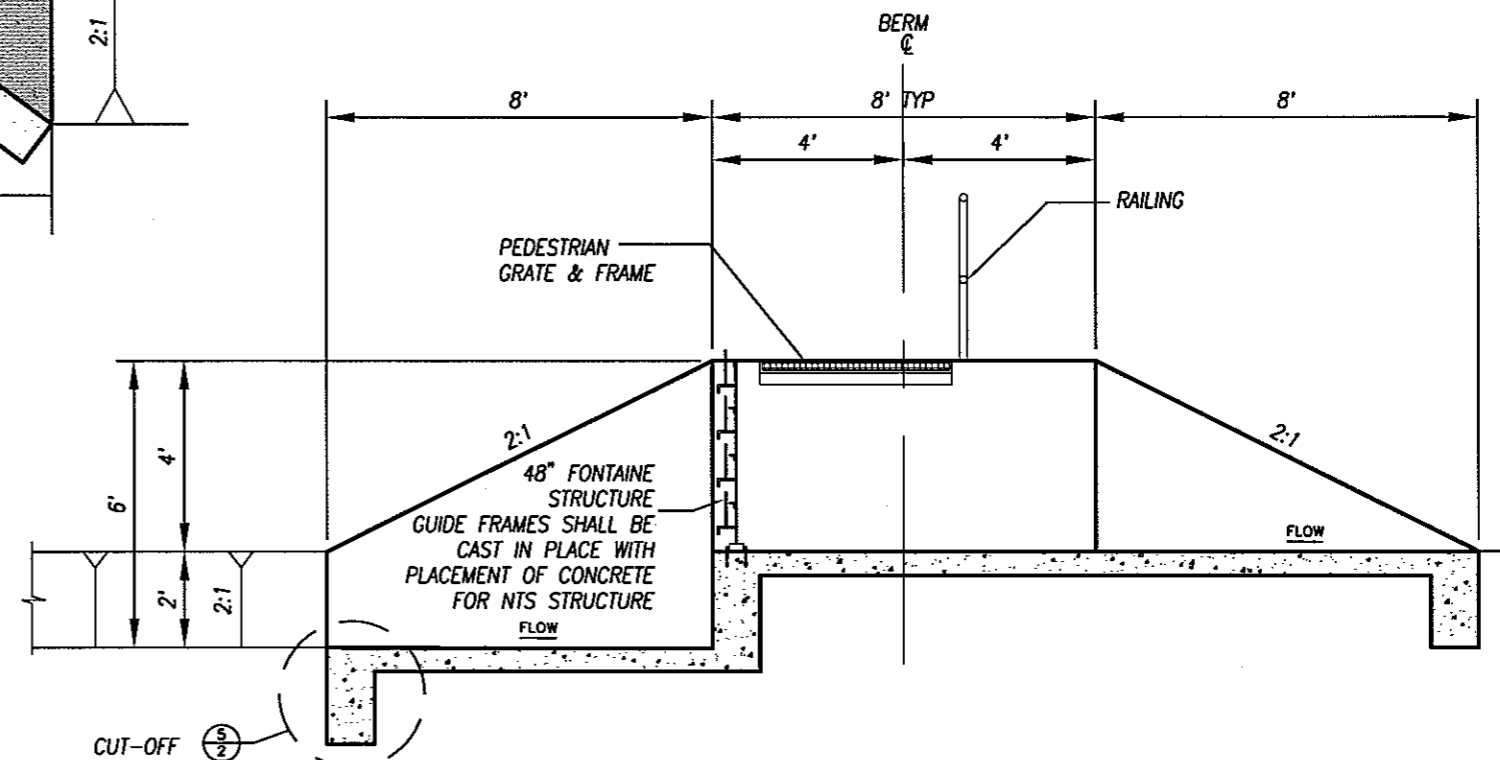

SECTION A-A
SCALE: 1" = 4'-0"

CUT-OFF WALL DETAIL

NO.	BY	DATE	REVISIONS	APPROVED	DATE:

Randall J. Sundberg 2/11/05
ENVIRONMENTAL QUALITY ENGINEER
J. S. [Signature] 3/24/05
ENVIRONMENTAL QUALITY MANAGER



IRVINE RANCH WATER DISTRICT NTS GUIDELINE DRAWING
INTERMEDIATE BERM
LEVEL CONTROL STRUCTURE DETAIL
NTS-3
SHEET 1 OF 2

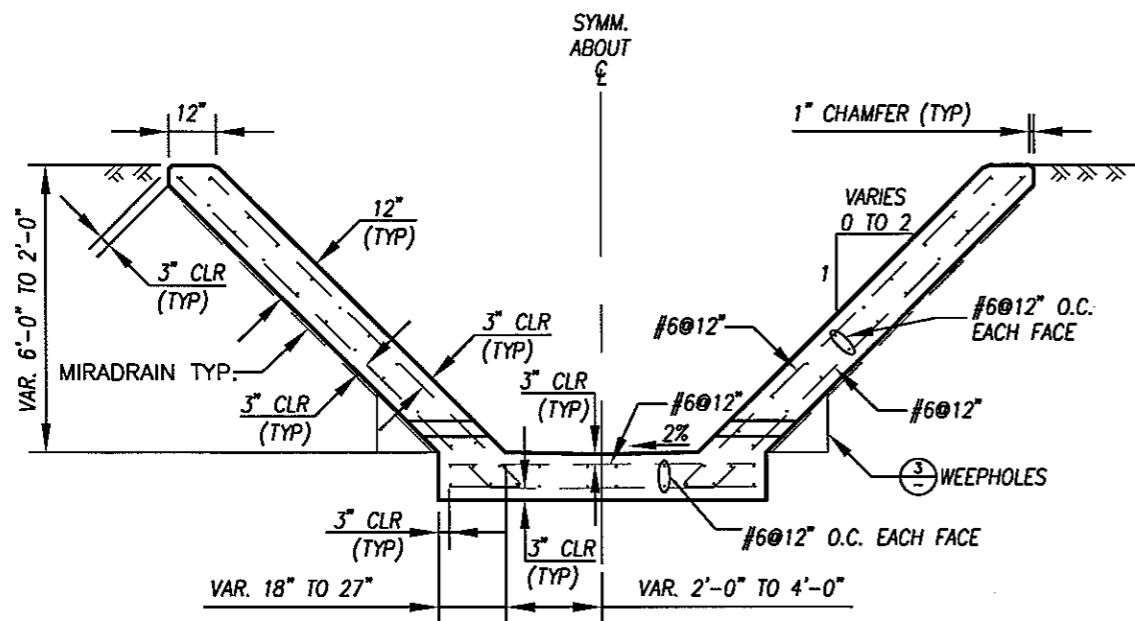

TRANSITION STRUCTURE SECTION 1
SCALE: 1" = 4'-0"

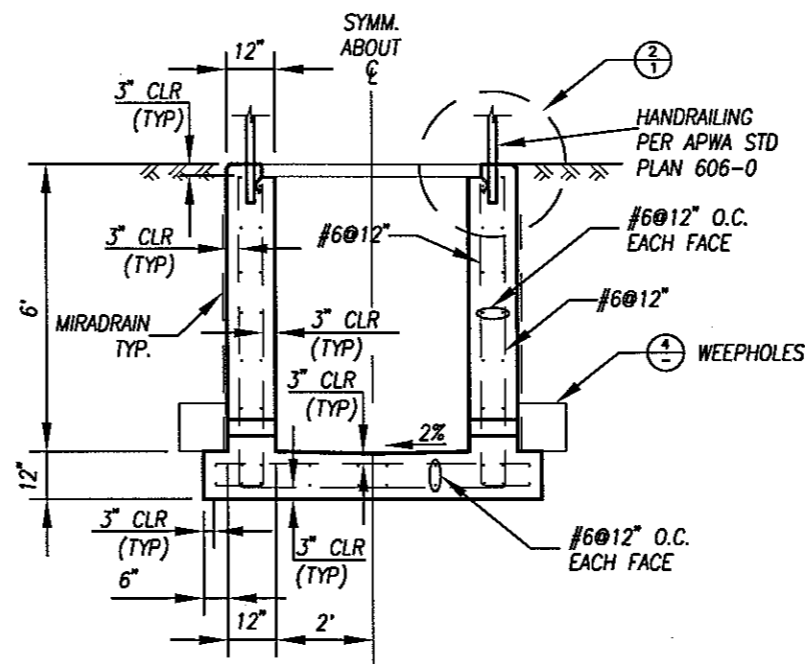

RECTANGULAR CHANNEL SECTION C 1
SCALE: 1" = 4'-0"
NOTE: FONTAINE STOP LOGS NOT SHOWN FOR CLARITY.

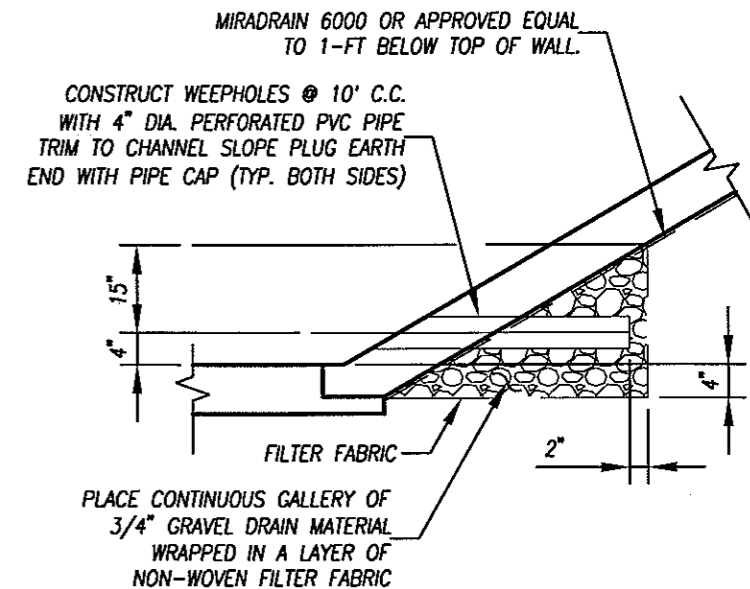

TRAP. CHANNEL WEEPHOLE DETAIL 3
N.T.S.

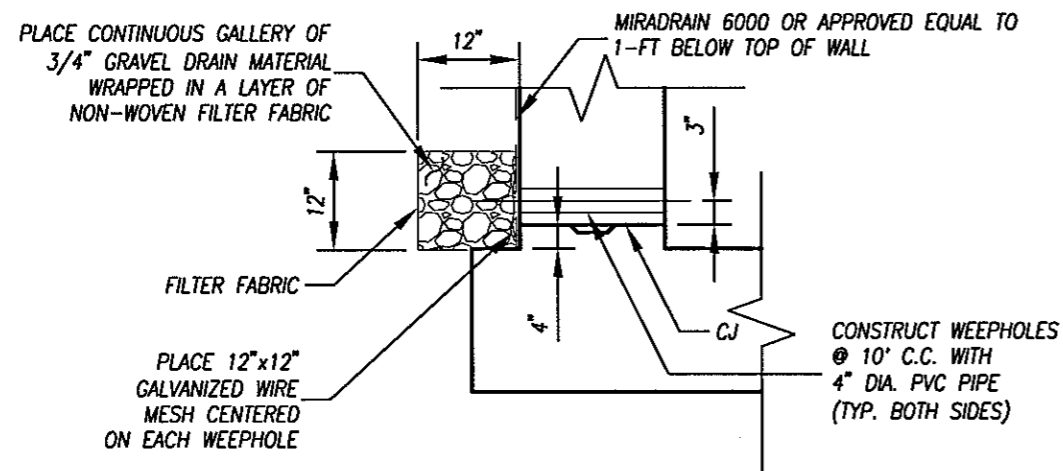

RECT. CHANNEL WEEPHOLE DETAIL 4
N.T.S.

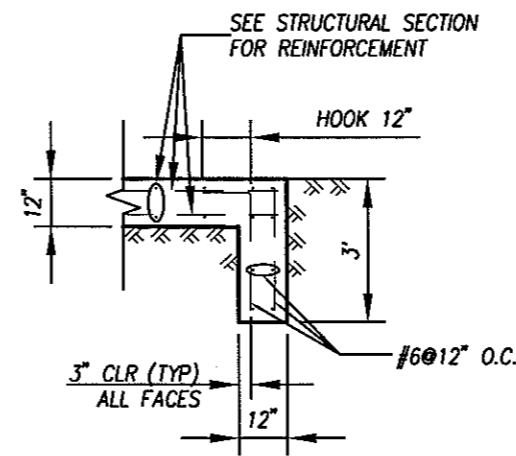

CUTOFF WALL 5 1
SCALE: 1" = 4'-0"

NOTE:
f'c = 4000 PSI @ 28 DAY
fy = 60000 #5
fy = 40000 #4

NO.	BY	DATE	REVISIONS	APPROVED	DATE:

Randall J. Lindberg 2/11/05
 ENVIRONMENTAL QUALITY ENGINEER
 DATE
[Signature] 3/22/05
 ENVIRONMENTAL QUALITY MANAGER
 DATE



IRVINE RANCH WATER DISTRICT NTS GUIDELINE DRAWING

INTERMEDIATE BERM
LEVEL CONTROL STRUCTURE DETAIL

NTS-3

SHEET 2 OF 2

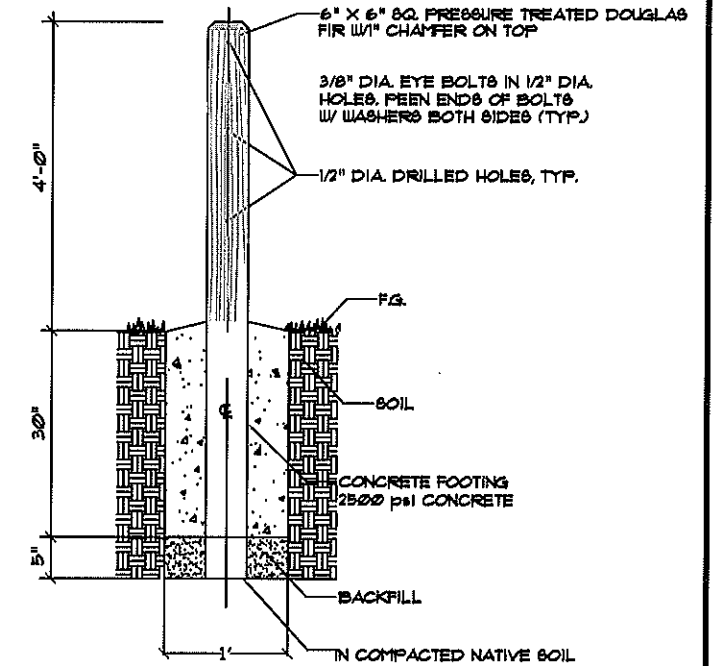
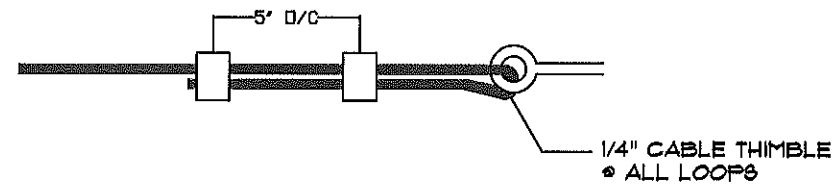

NOTES:

1. CABLE SHALL NOT BE SPLICED BETWEEN END POSTS.
2. ALL HARDWARE TO BE GALVANIZED.
3. POSTS TO BE VERTICAL.
4. THE CONTRACTOR SHALL VERIFY ALL DEPENDENT DIMENSIONS IN THE FIELD BEFORE ORDERING OR FABRICATING ANY MATERIAL.
5. LINE POSTS SHALL BE TRUSSED DIAGONALLY IN BOTH DIRECTIONS AT INTERVALS NOT TO EXCEED 1,000 FT.
6. TYPICAL END SPANS, BRACED IN BOTH DIRECTIONS SHALL BE CONSTRUCTED AT CHANGES IN LINE WHERE THE ANGLE OF DEFLECTION IS 15° OR MORE.
7. PROVIDE THIMBLES AT ALL CABLE LOOPS.
8. CONTRACTORS SHALL SUBMIT SHOP DRAWINGS TO L.A. FOR CABLE RAIL LAYOUT (CRIMP, POSTS, ETC.) BEFORE ORDERING OR FABRICATING ANY MATERIALS.
9. CONTRACTOR TO SUBMIT MOCK-UP OF WOOD POST.
10. PLANT 1 GALLON CONTAINER CALIFORNIA ROSES (ROSA CALIFORNICA) @ 5' O.C. & PROVIDE DRIP IRRIGATION PER EACH.
11. 3/8" DIA TURNBUCKLE W/ 4 1/2" WHY. ADJUSTMENT 100'-0" +/-

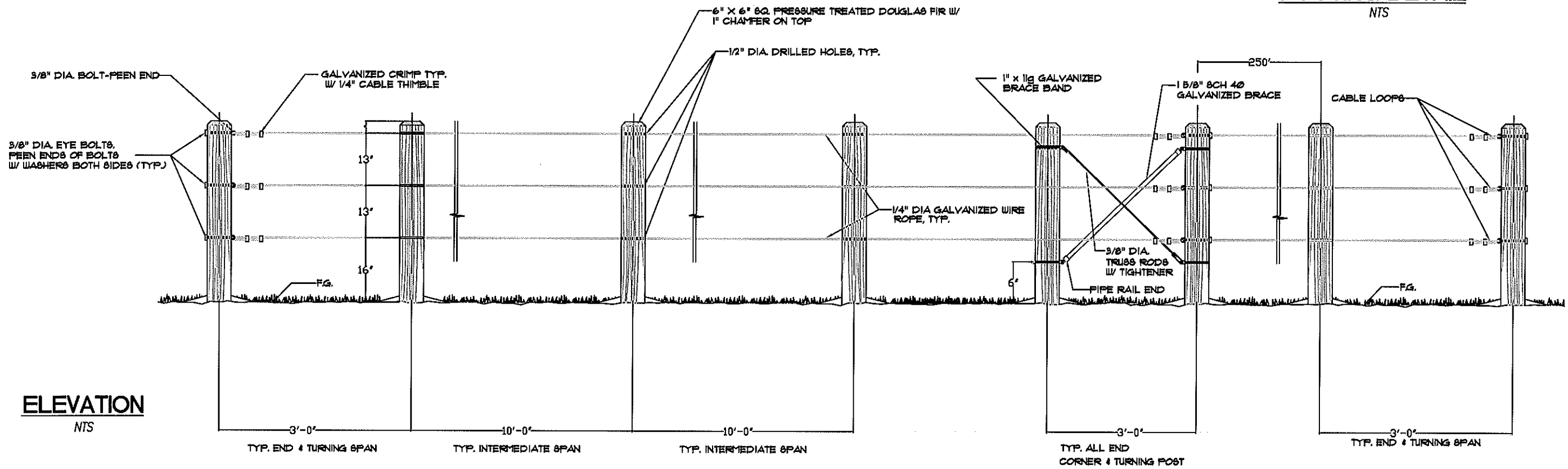

FOOTING DETAIL
NTS



NO.	BY	DATE	REVISIONS	APPROVED	DATE: 01-18-07			IRVINE RANCH WATER DISTRICT NTS GUIDELINE DRAWING	
						 ENVIRONMENTAL QUALITY ENGINEER DATE: 1/22/07		POST AND CABLE FENCE	
						 ENVIRONMENTAL QUALITY MANAGER DATE: 1/22/07		NTS-4	
								SHEET 1 OF 1	